

***Narrative Nexus: Uniting Stories and Spaces  
of the The Public Library in Stockholm***

**Project Book**  
*Archive*

## Overview

1. *Prologue*: The Stockholm Public Library
2. Developing the Library
3. The Concept
4. The Story as a Project
5. *Epilogue*



## *Prologue: The Stockholm City Library*



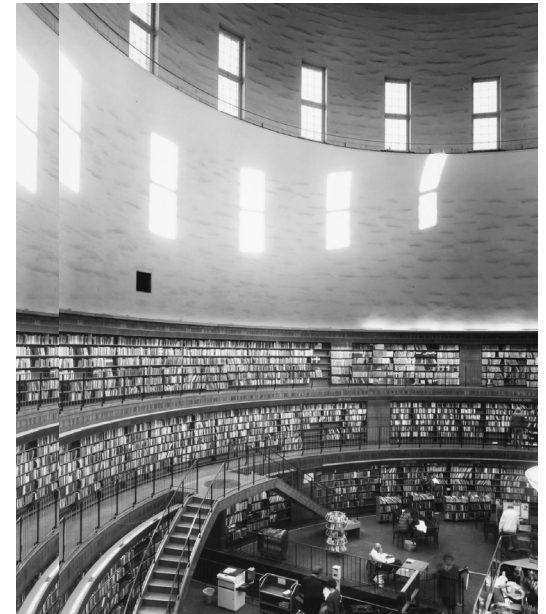

**1920**  
*Gunnar Asplund*  
 Inspiring trip with the City Librarian Fredrik Hjelmquist to the USA

**1924**  
*Gunnar Asplund*  
 Final Drawings

**1928**  
 Library Inauguration

**1932**  
 Erection of house book depositories and a lecture hall

**1950s**  
*Hans Asplund*  
 Additional symmetrical staircase, new lifts & utilisation of light shafts

**1970s**  
 Adjusting the library to the disabled & new lifts.

**2006**  
 First International Competition

**2012**  
 Conservation Works

**2014**  
 Revised International Competition

**2014**  
 Winning Proposal by Caruso St John Architects

**2024**  
 New Brief & Project

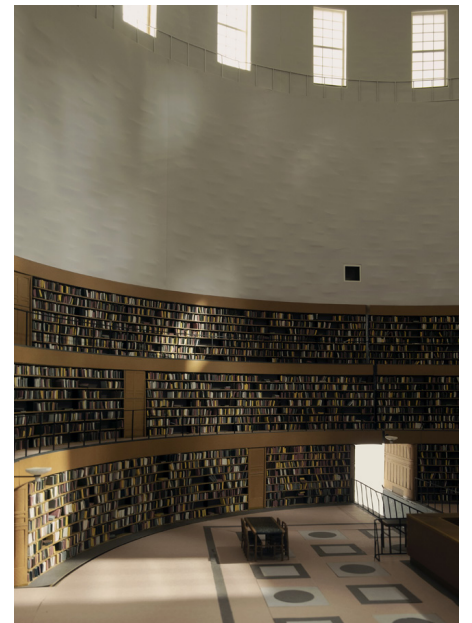
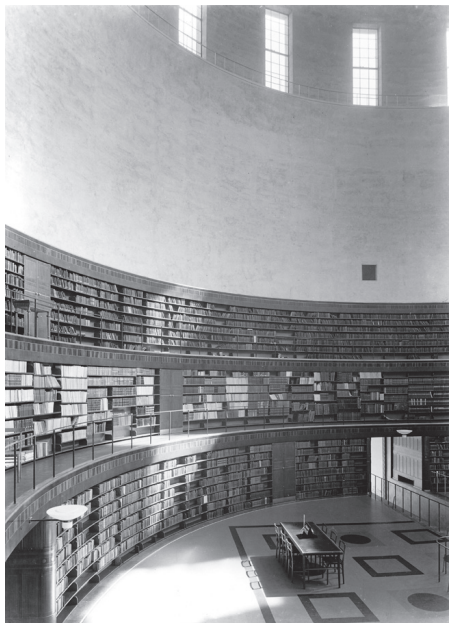
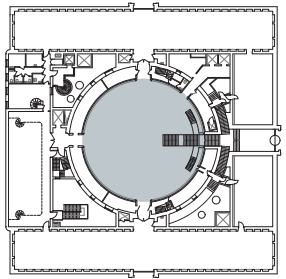



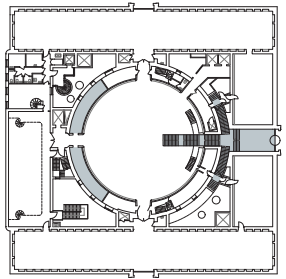

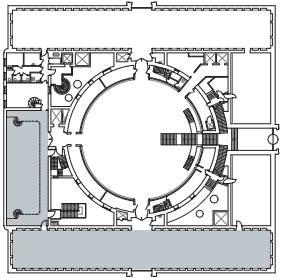

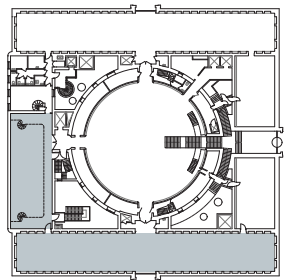
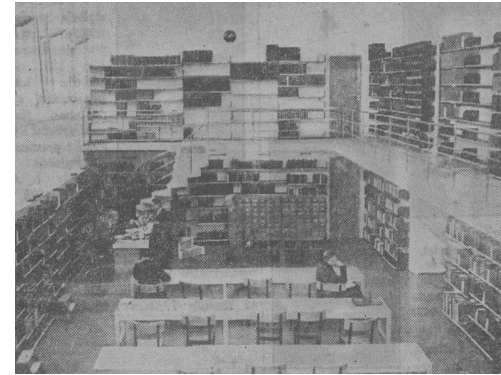

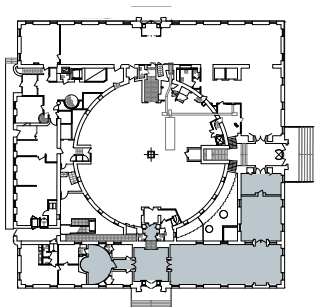



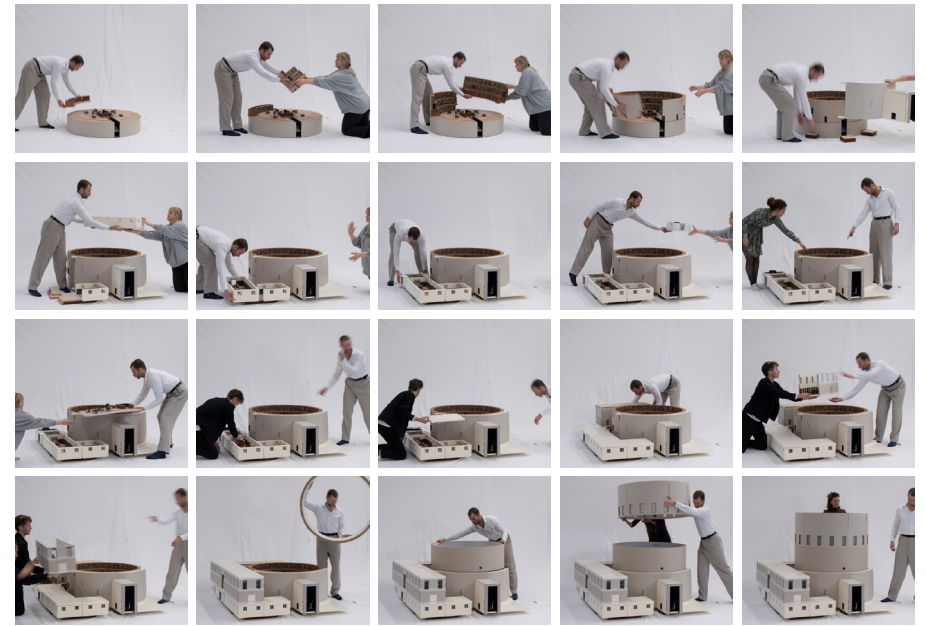
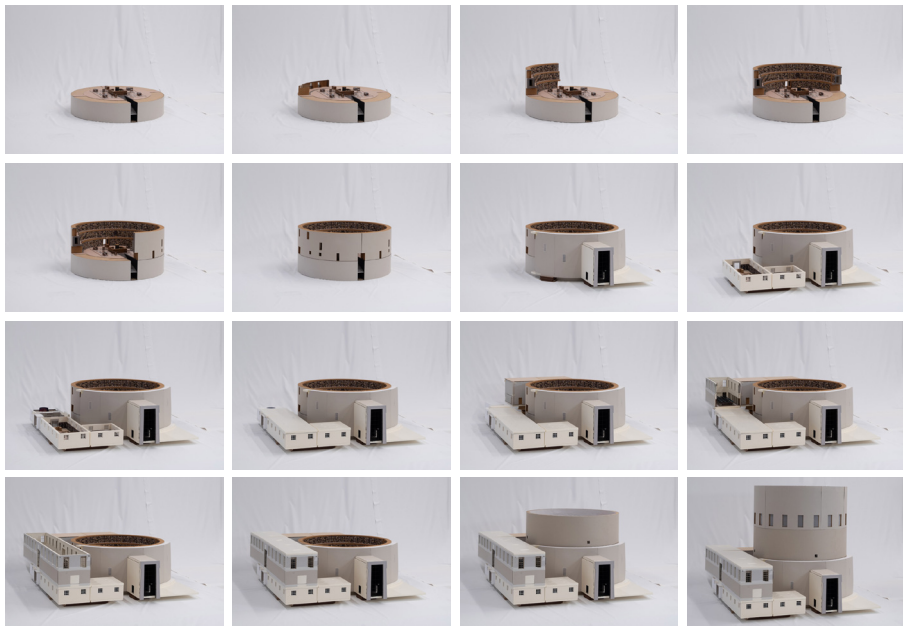



# Developing The Library

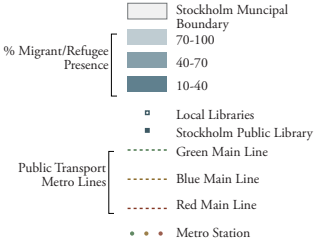
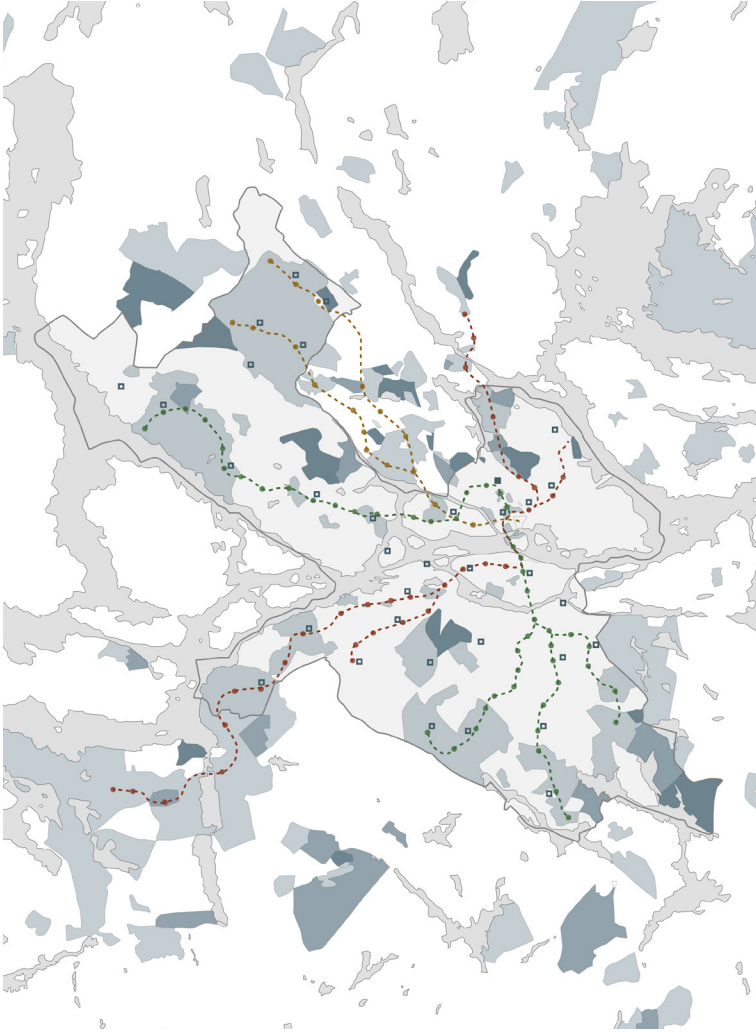

Existing Asplund Library

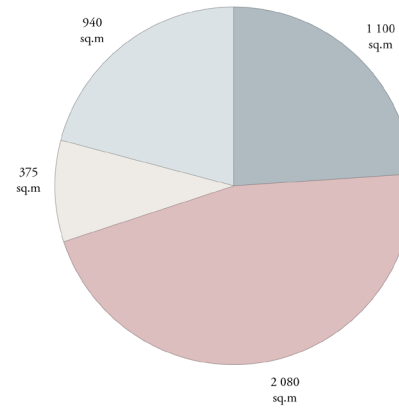

Competition Brief 2006

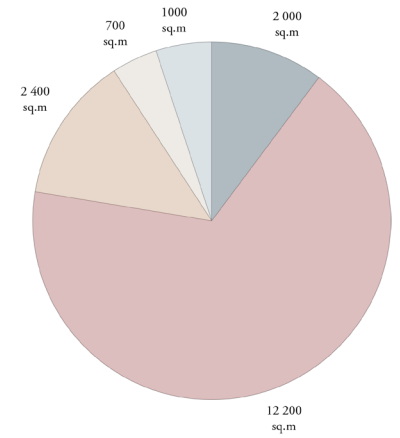

CSTJ Winning Proposal

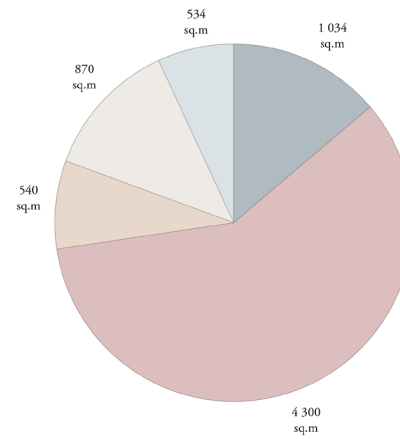

The New Proposal

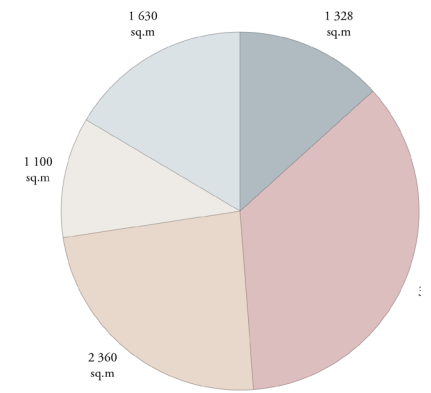

- Staff
- Collection & Reading Rooms
- Workshops/Labs/Studios
- Public Circulation/WC
- Storage

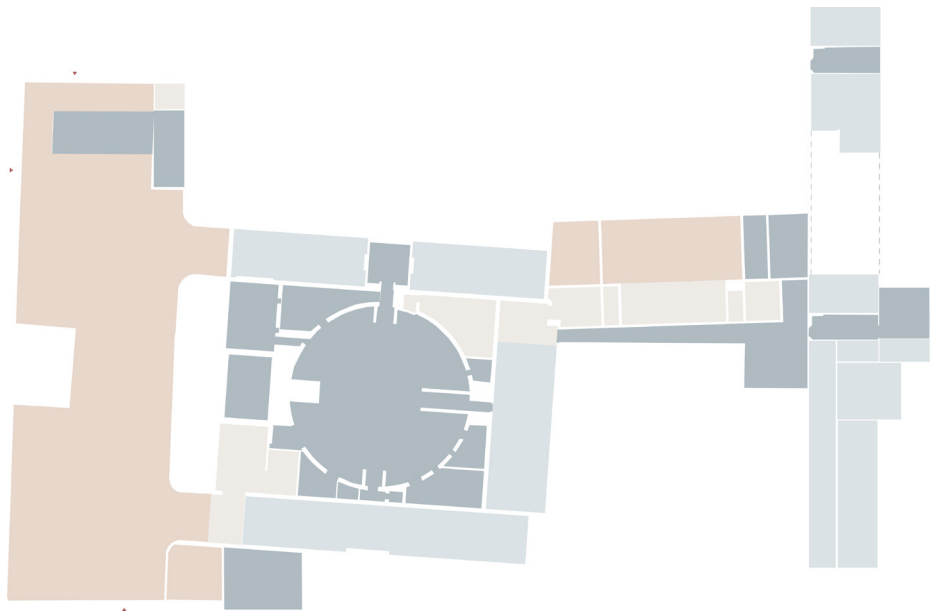

Bazaar & Basement

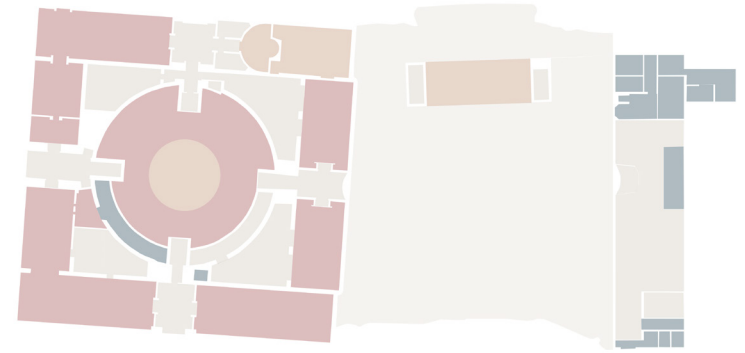

Lower Ground Floor & Ground Floor

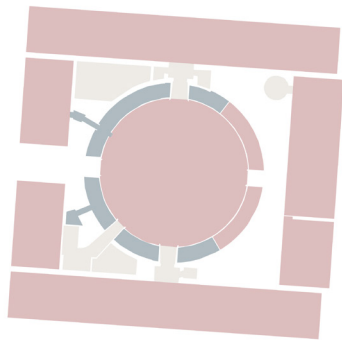

First Floor



Upper Floor



- Staff
- Collection & Reading Rooms
- Workshops/Labs/Studios
- Public Circulation/WC
- Storage

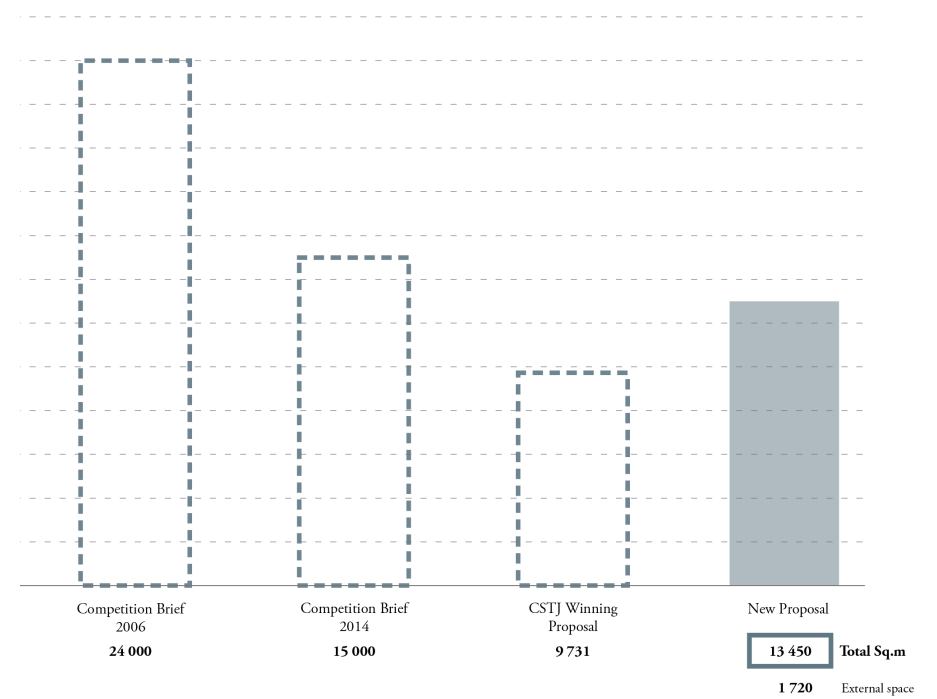
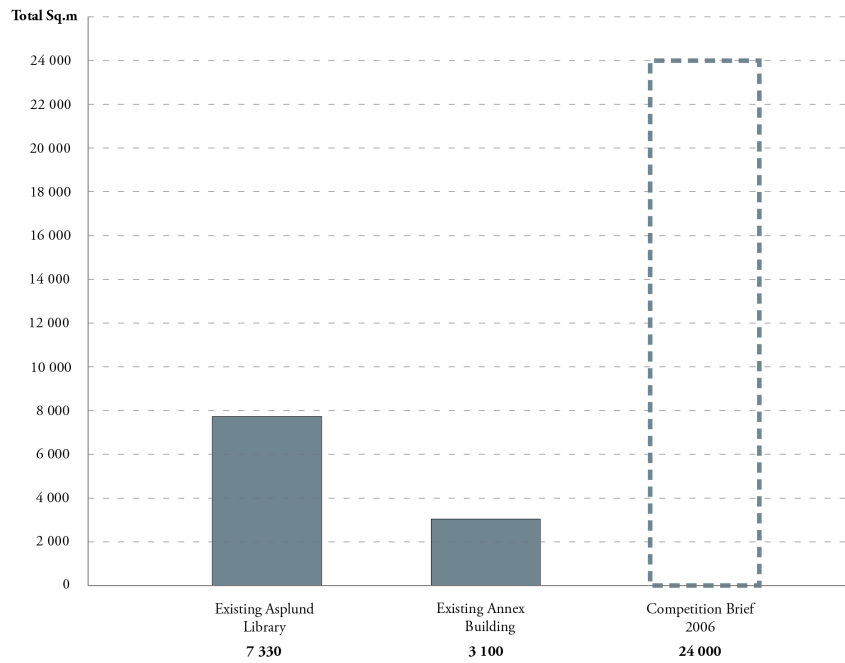



The Bazaar Refurbishment, Extension  
& New Courtyard Gardens



The Asplund Library Refurbishment  
& New Lightwell Spaces



The Annex Refurbishment, New Connection Link  
with the Library & Delivery Point



New Storytelling Building, Lecture Rooms  
& Outdoor Space with Garden

## The Concept



Film Still from **'The color of Pomegranates'**  
by Sergei Parajanov



**The Great Exhibition: India**  
Crystal Palace, London

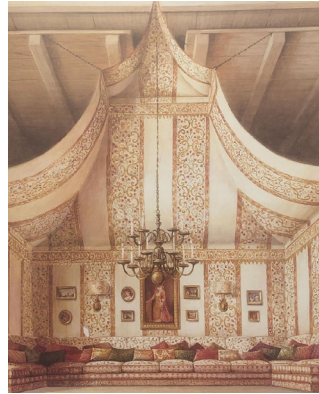

**A colossal fabric-hung**  
by Renzo Mongiardino

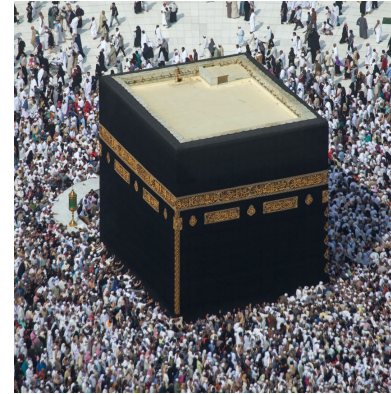

**The Kaaba, 'cube' in Arabic, the house of God**  
Grand Mosque of Mecca



**Nouakchott, Mauritania**



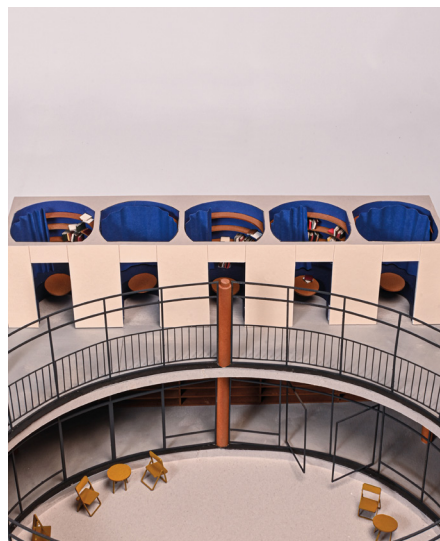

**P1 A Room for A Library**  
Equilibrium of the Individual and Collective



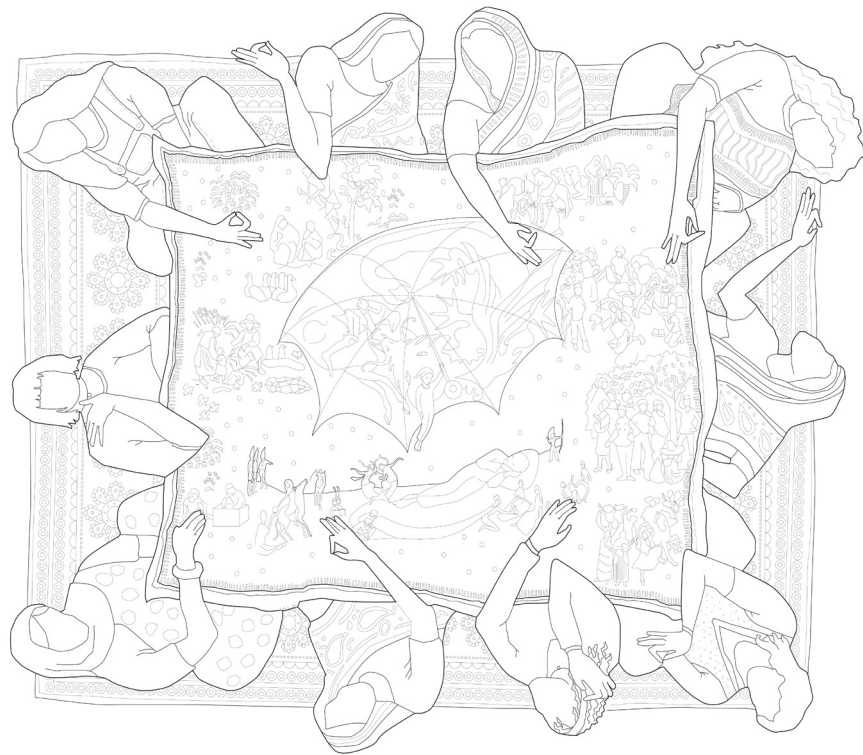

**'A book read by a thousand different people is a thousand different books.'**  
 - Andrei Tarkovsky



**'The Library'**  
 by Giuseppe Maria Crespi

## The Story as A Project

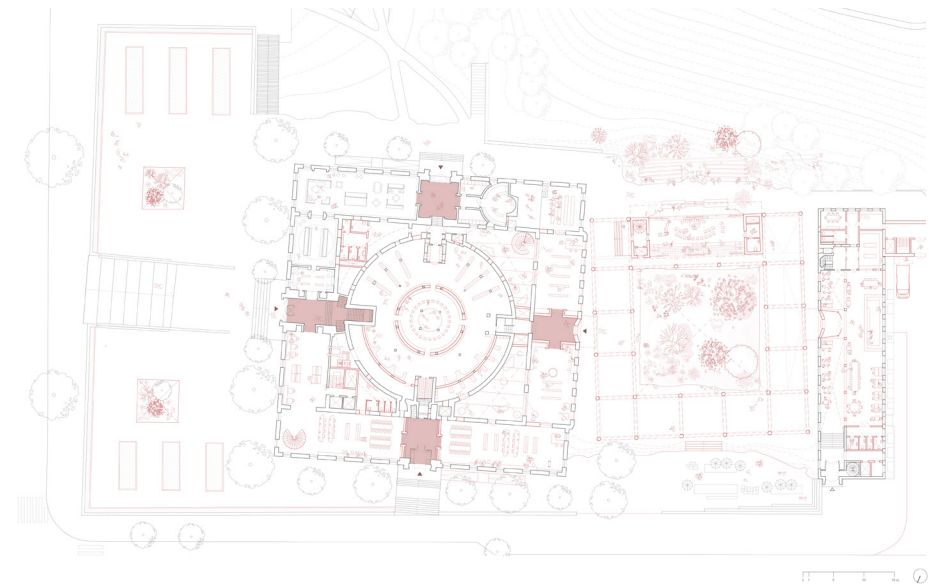

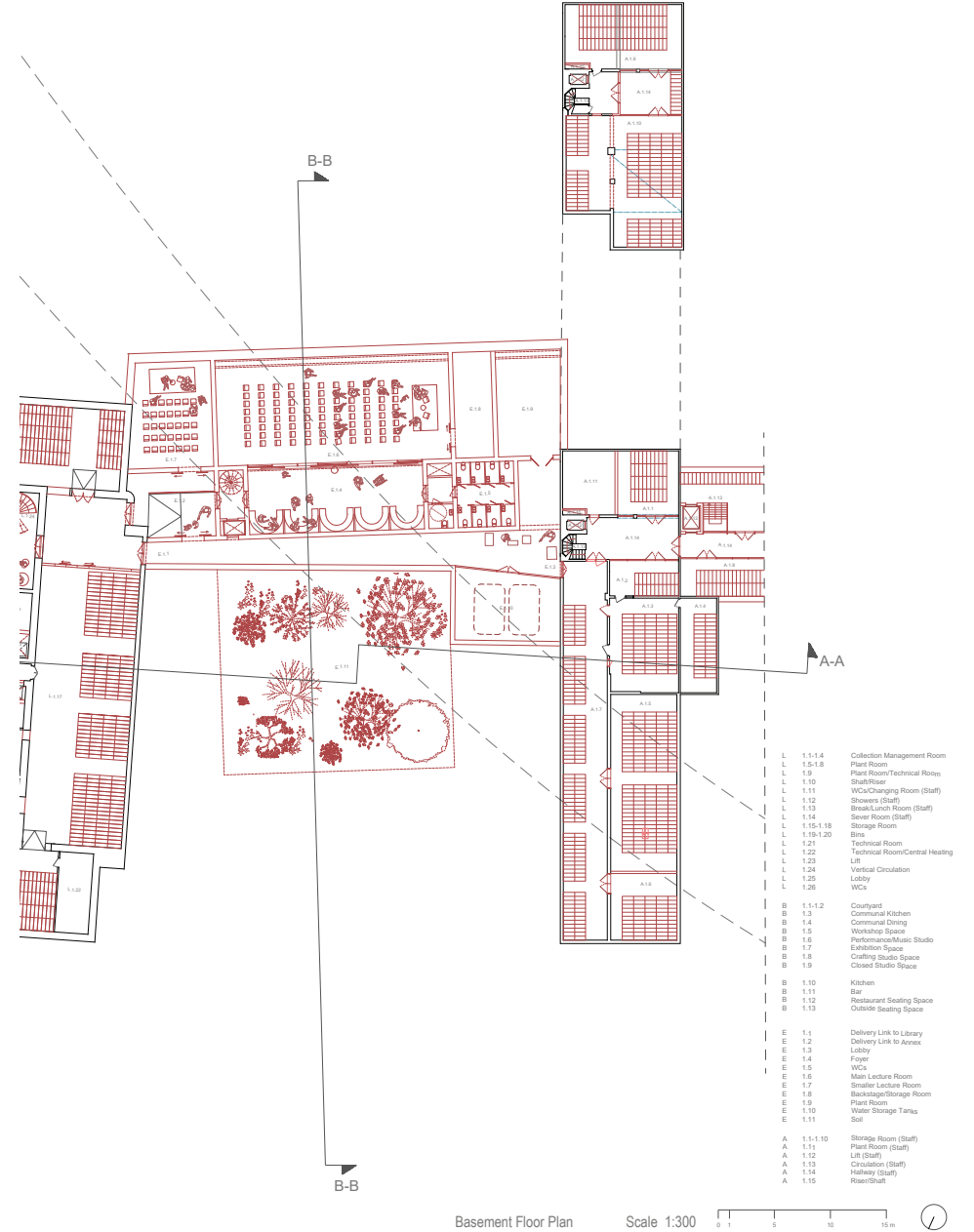
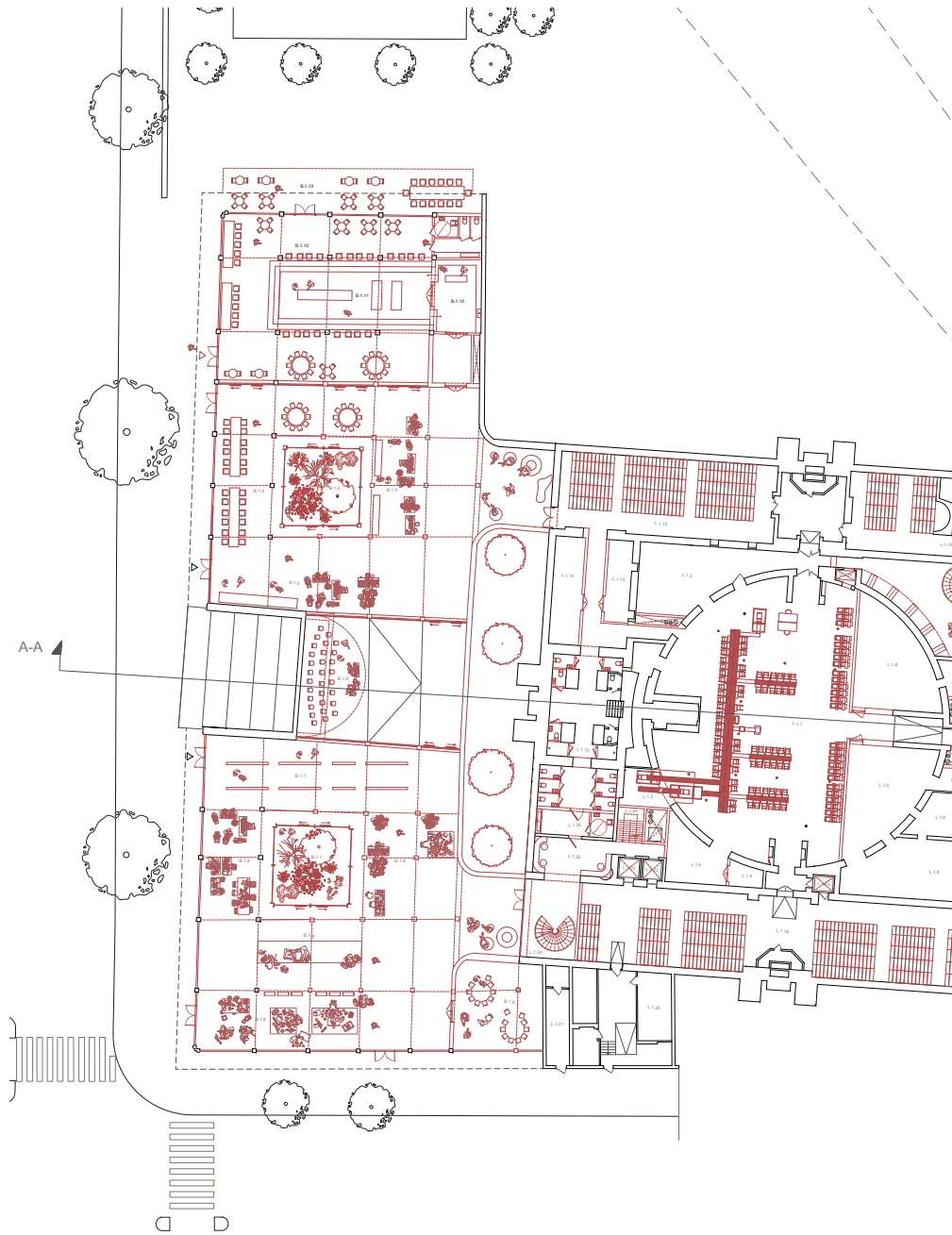

Basement Floor Plan

Scale 1:300





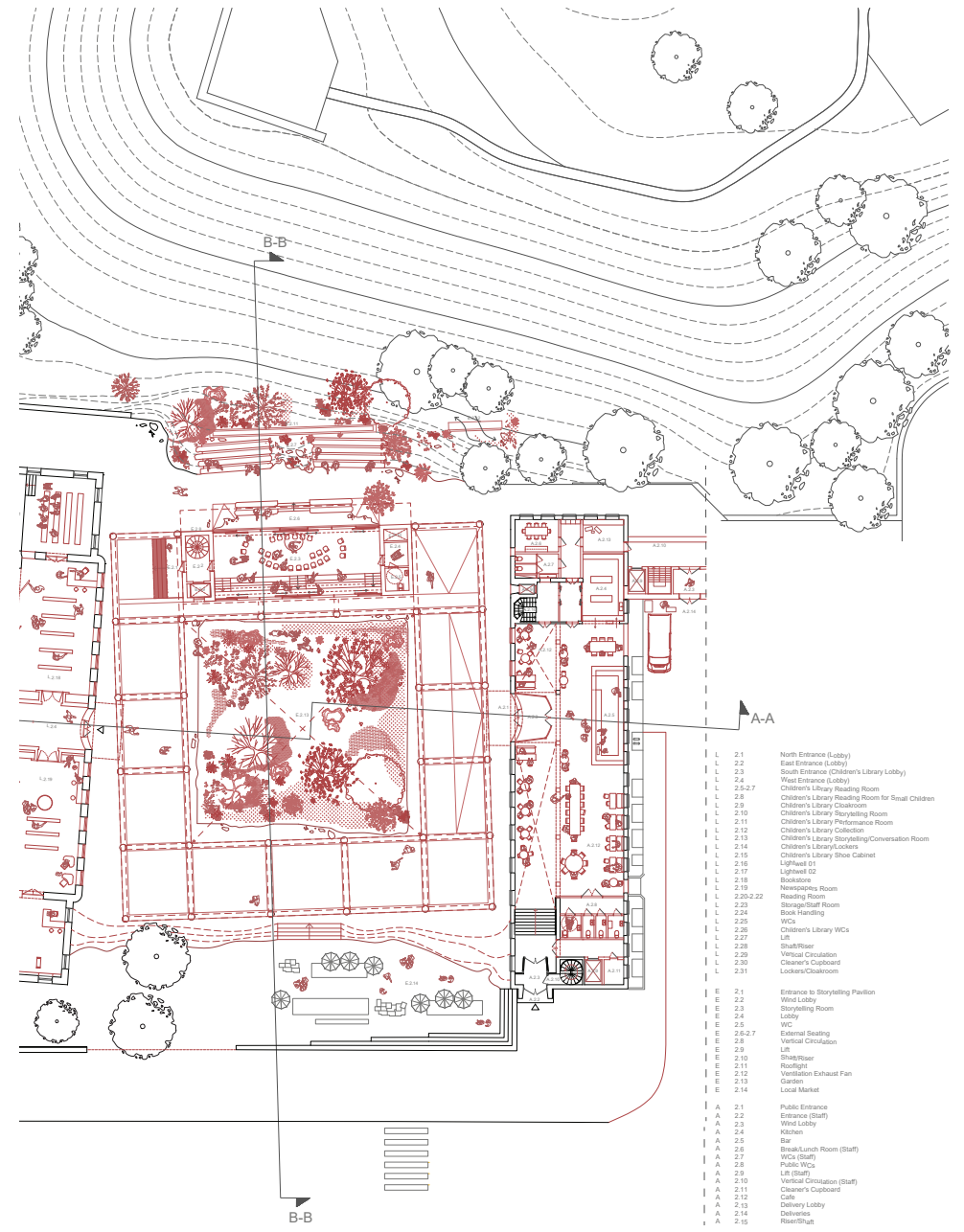
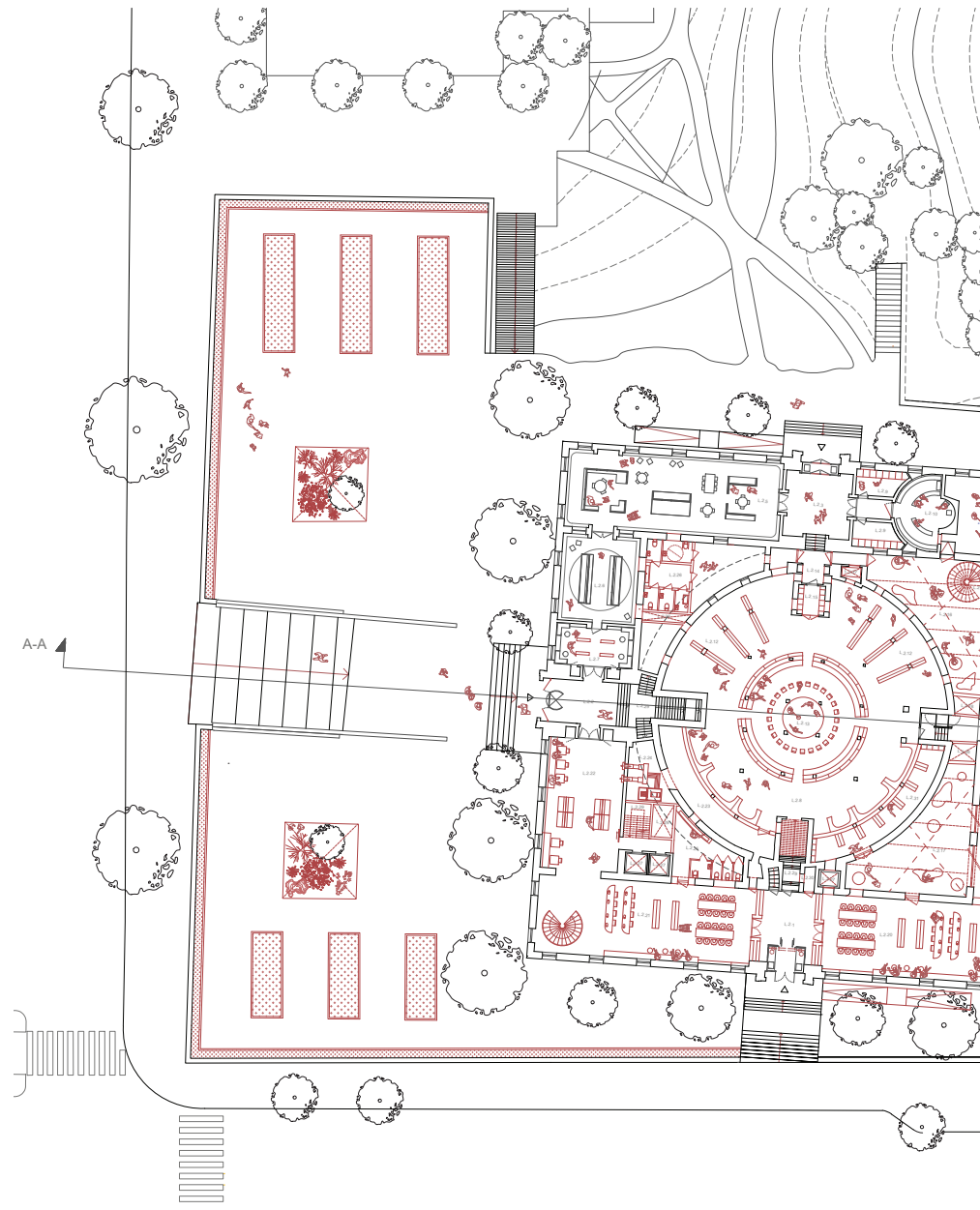

Lower/Ground Floor Plan

Scale 1:300



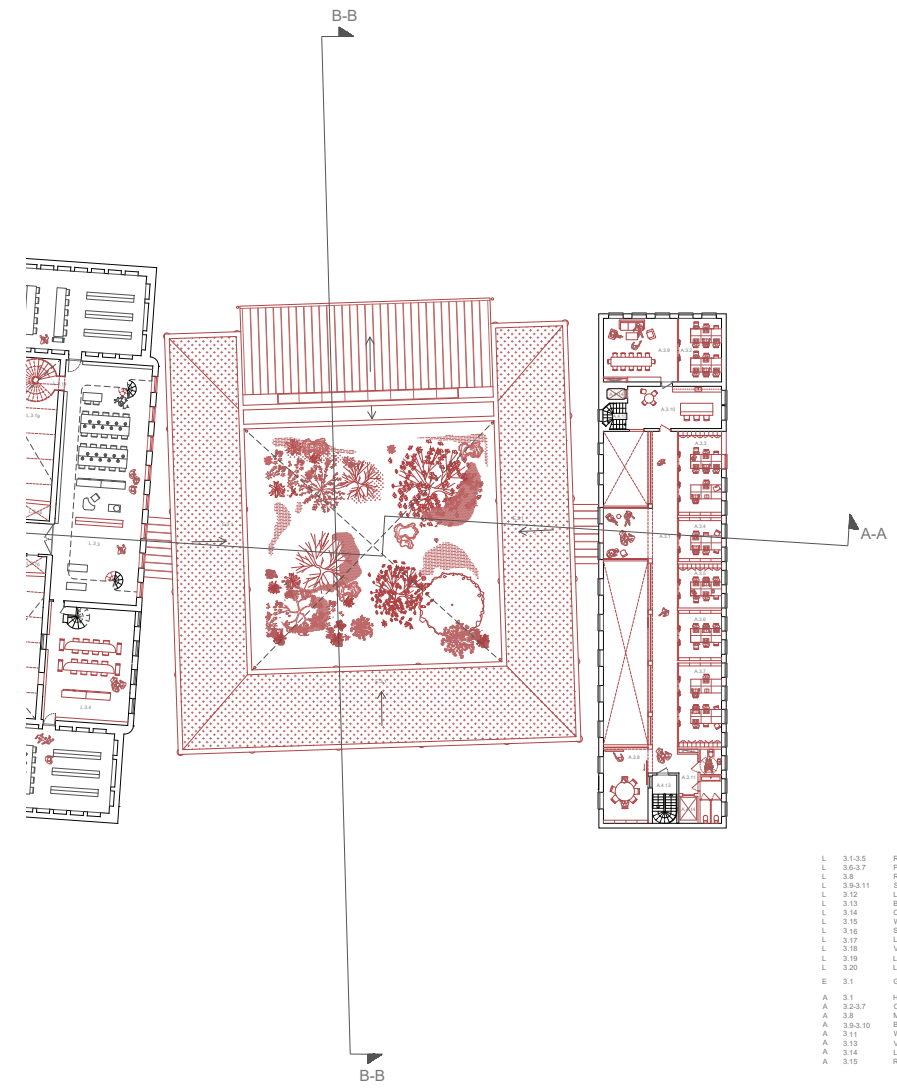
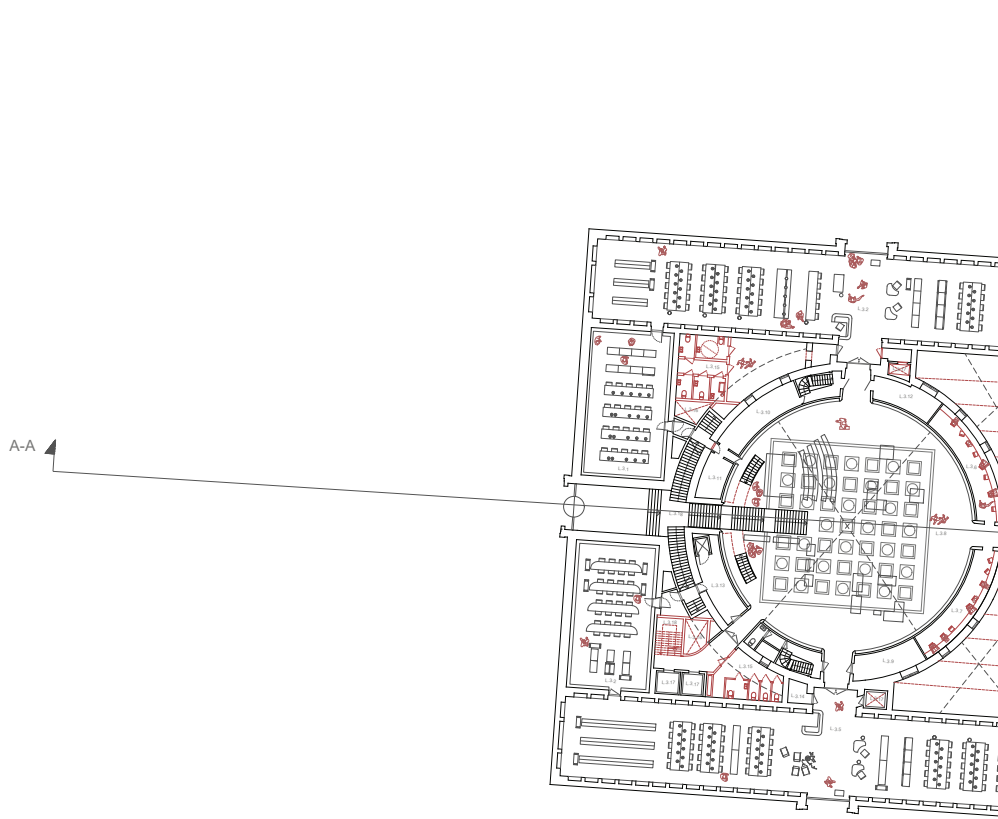

- L 3.1-3.5 Reading Room
- L 3.6-3.7 Poche Reading Room
- L 3.8 Rotunda
- L 3.9-3.11 Stacks/Store
- L 3.12 Loan Advice
- L 3.13 Book Handling
- L 3.14 Cleaner's Cupboard
- L 3.15 WCs
- L 3.16 StaffRiser
- L 3.17 Lift
- L 3.18 Vertical Circulation
- L 3.19 Lightwell 01 (Void)
- L 3.20 Lightwell 02 (Void)
- E 3.1 Grass
- A 3.1 Hallway
- A 3.2-3.7 Office (Staff)
- A 3.8 Meeting Room (Staff)
- A 3.9-3.10 Break/Snack Room (Staff)
- A 3.11 WCs (Staff)
- A 3.13 Vertical Circulation (Staff)
- A 3.14 Lift (Staff)
- A 3.15 Riser/Shaft

First Floor Plan

Scale 1:300



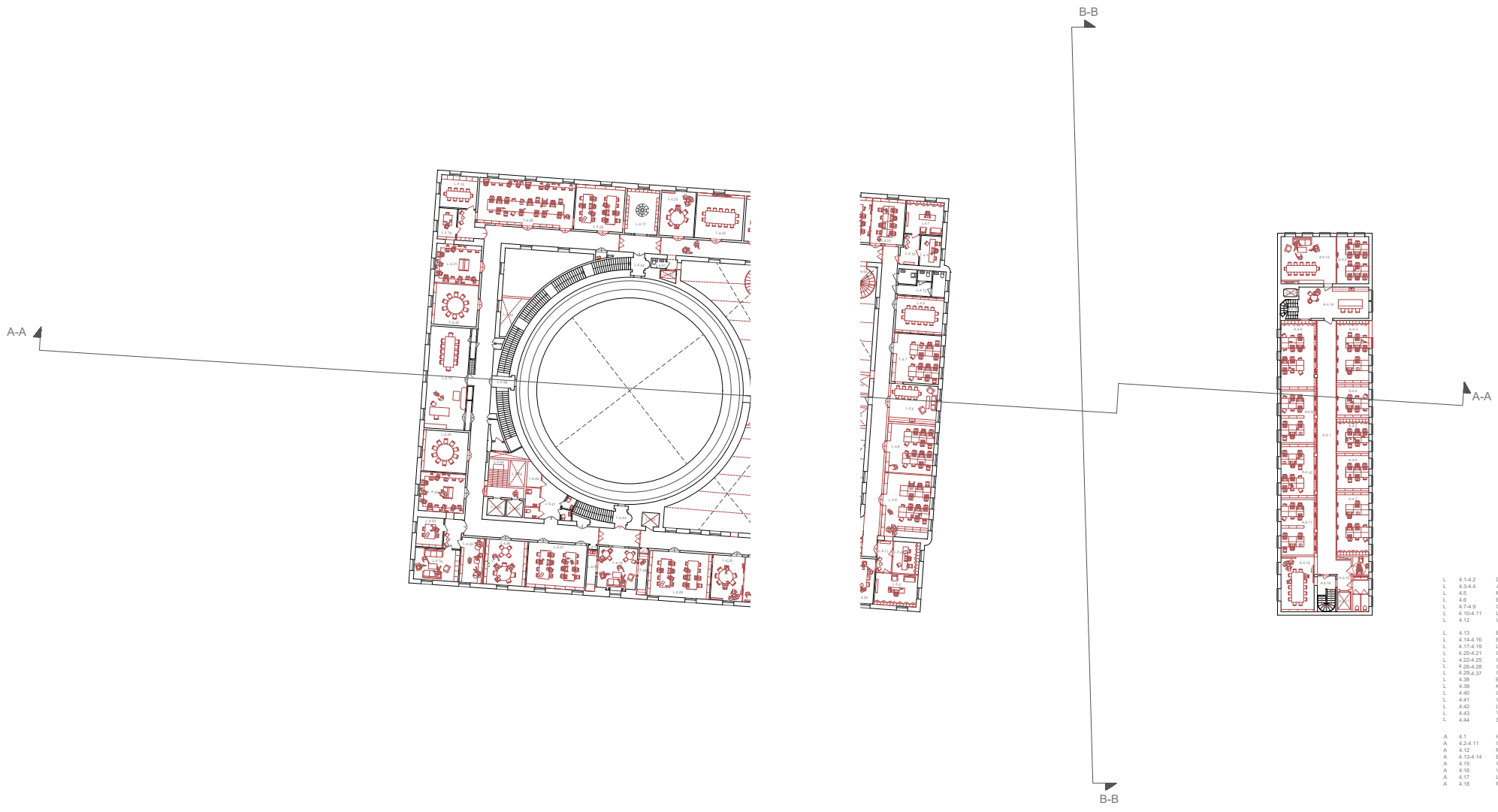

- L 4.14.2 Director's Office
- L 4.3-4.4 Administrative Office (Secretariat)
- L 4.5 Meeting Room (Staff)
- L 4.6 Break/Lunch Room (Staff)
- L 4.7-4.9 Office (Staff)
- L 4.10-4.11 Lobby (Staff)
- L 4.12 WCs (Staff)
- L 4.13 Exhibition Room
- L 4.14-4.16 Break Room
- L 4.17-4.19 Lockers
- L 4.20-4.21 Conversation Room
- L 4.22-4.25 Group Room / Meeting Room
- L 4.26-4.28 Group Room (Semi-Public)
- L 4.29-4.37 Group Room
- L 4.38 Bridge
- L 4.39 Kitchenette
- L 4.40 Cleaner's Cupboard
- L 4.41 WCs
- L 4.42 Lift
- L 4.43 Vertical Circulation
- L 4.44 Shaft/Riser
- A 4.1 Hallway
- A 4.2-4.11 Office (Staff)
- A 4.12 Meeting Room (Staff)
- A 4.13-4.14 Break/Lunch Room (Staff)
- A 4.15 WCs (Staff)
- A 4.16 Vertical Circulation (Staff)
- A 4.17 Lift (Staff)
- A 4.18 Riser/Shaft

Second Floor Plan Scale 1:300 0 1 5 10 15 m

- Public
- Private
- Circulation

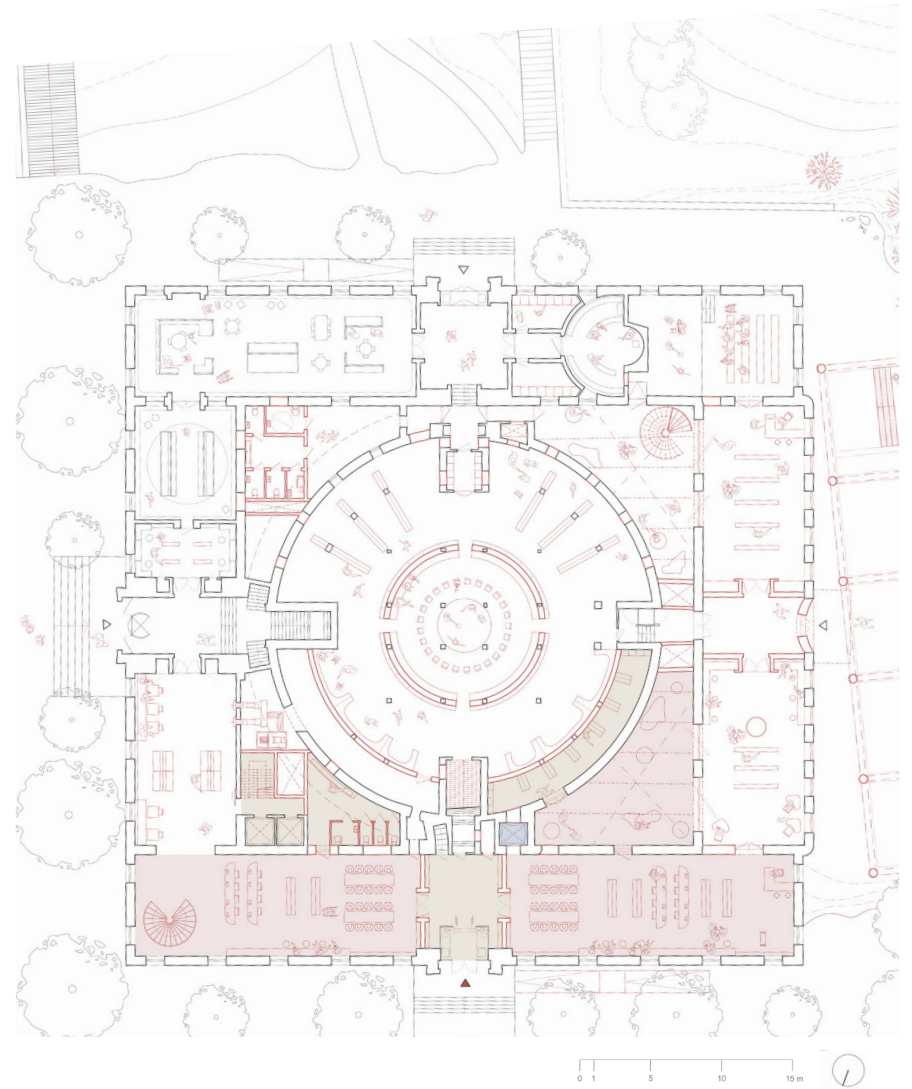

- Public
- Private
- Circulation

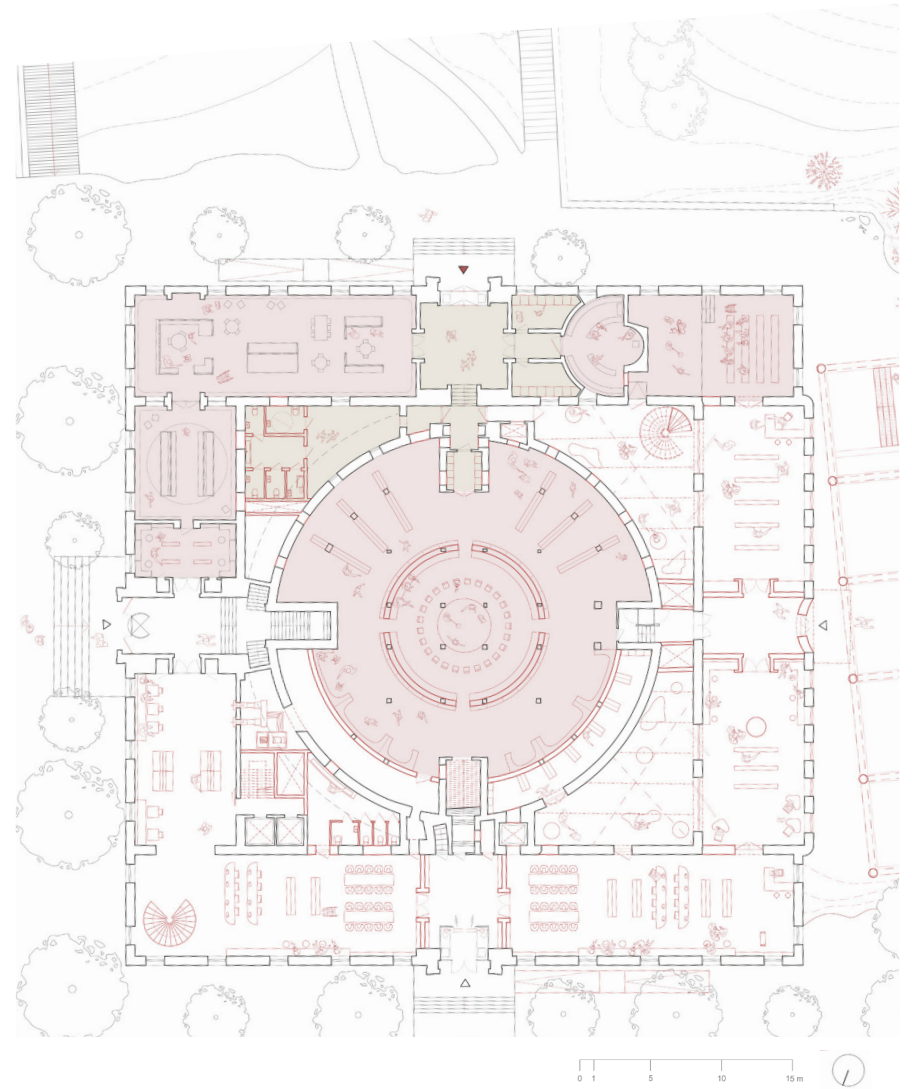



- Public
- Private
- Circulation

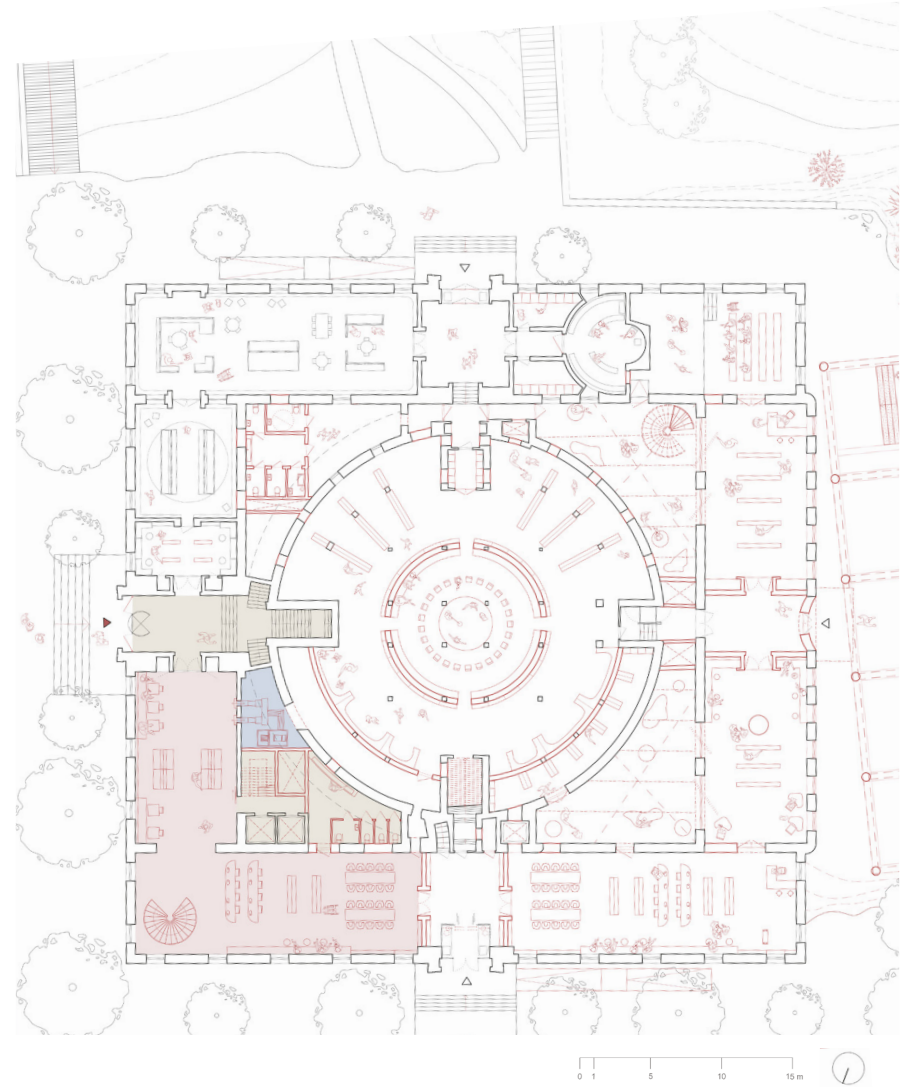

- Public
- Private
- Circulation

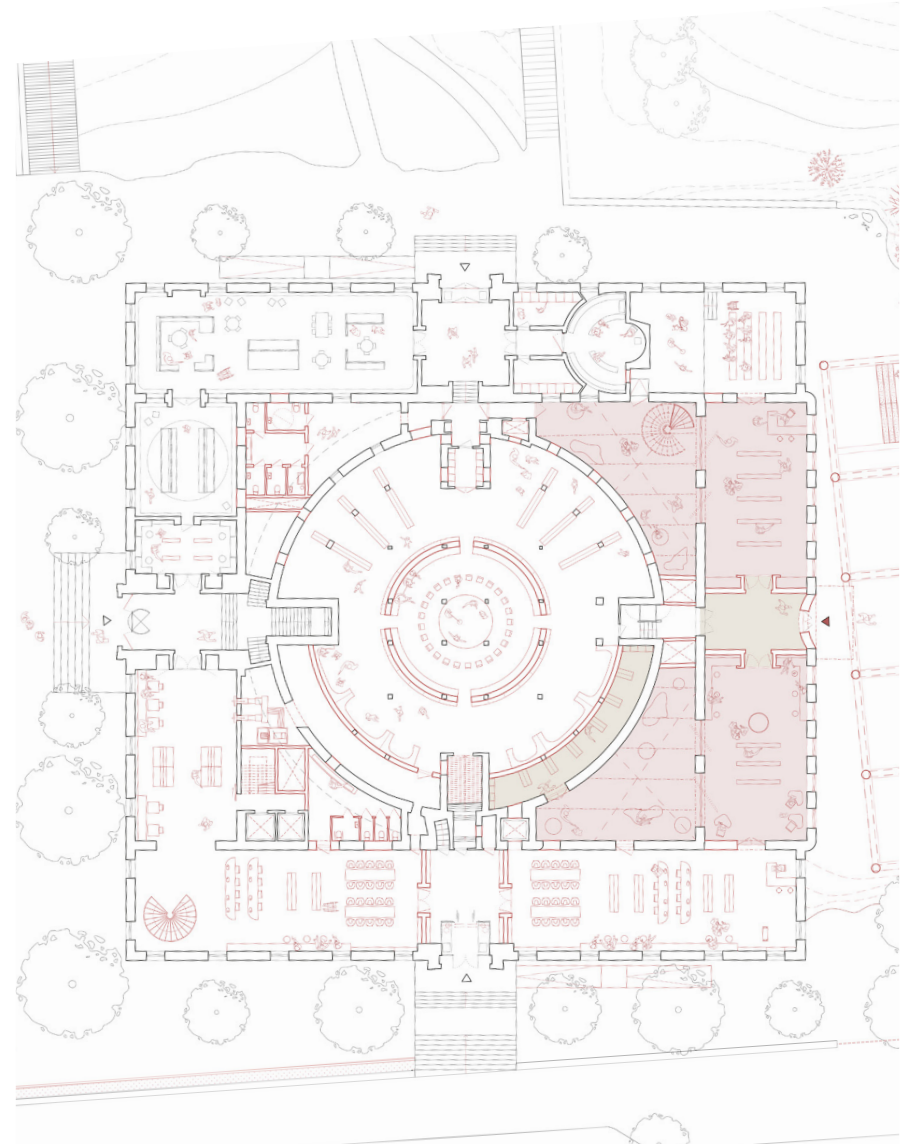

- Public
- Private
- Circulation

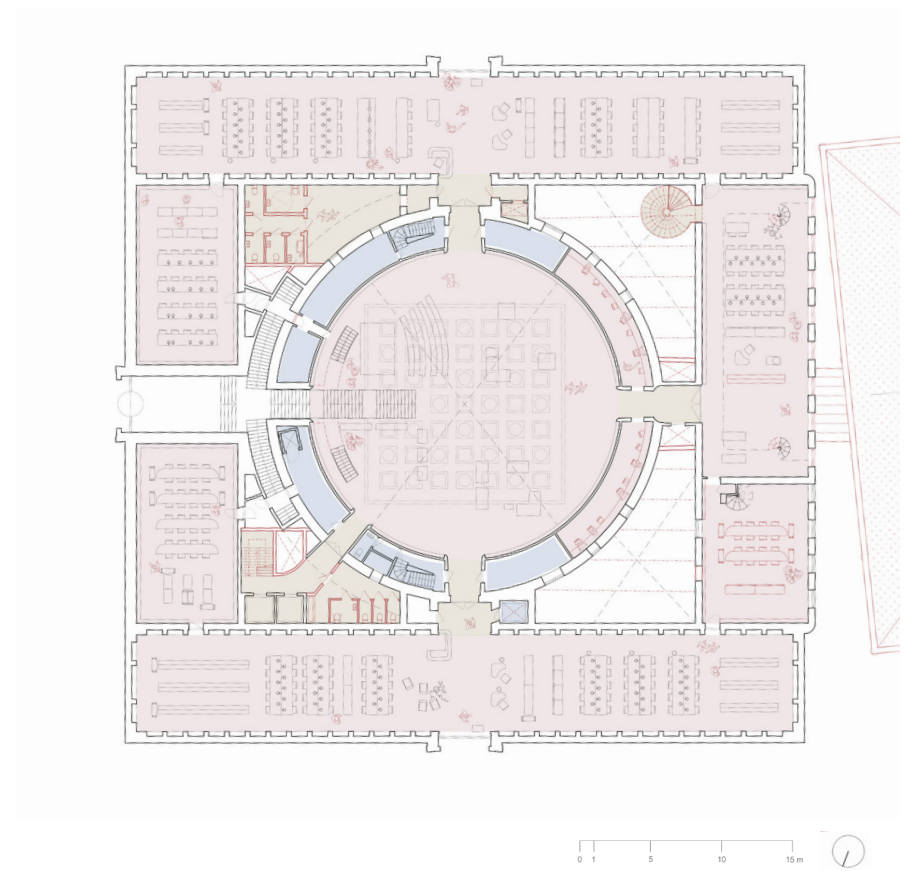

- Public
- Private
- Circulation

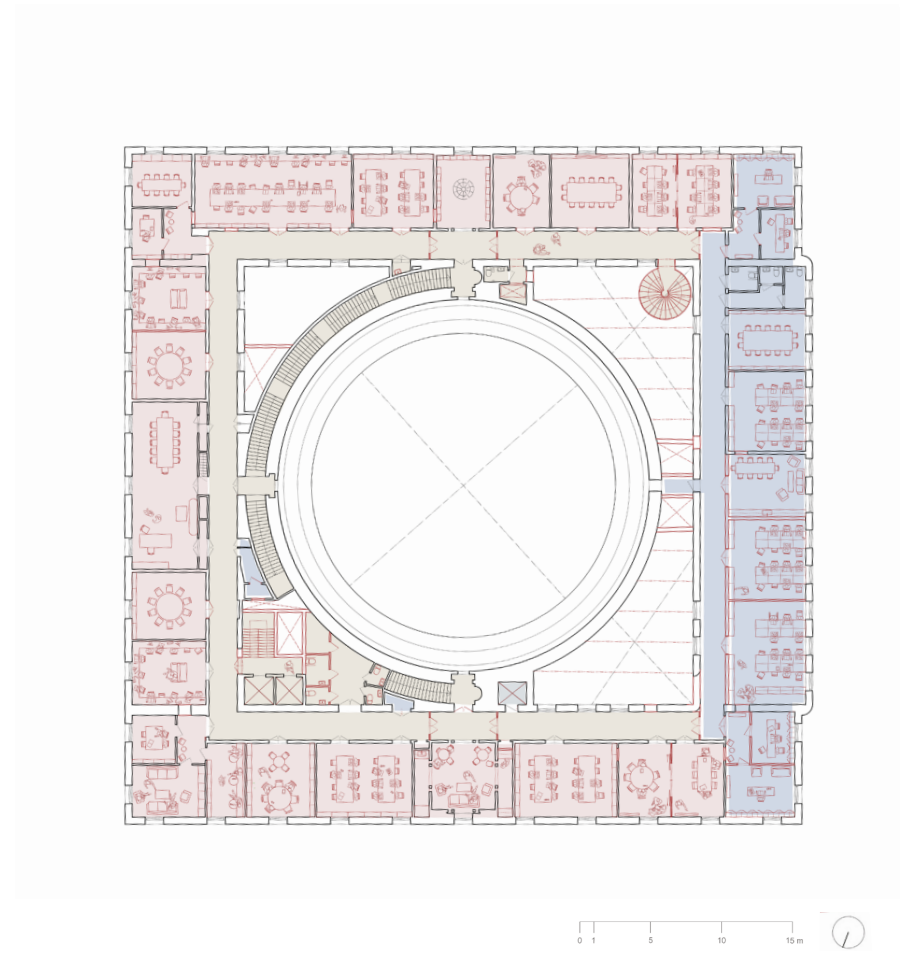

- Public
- Private
- Circulation

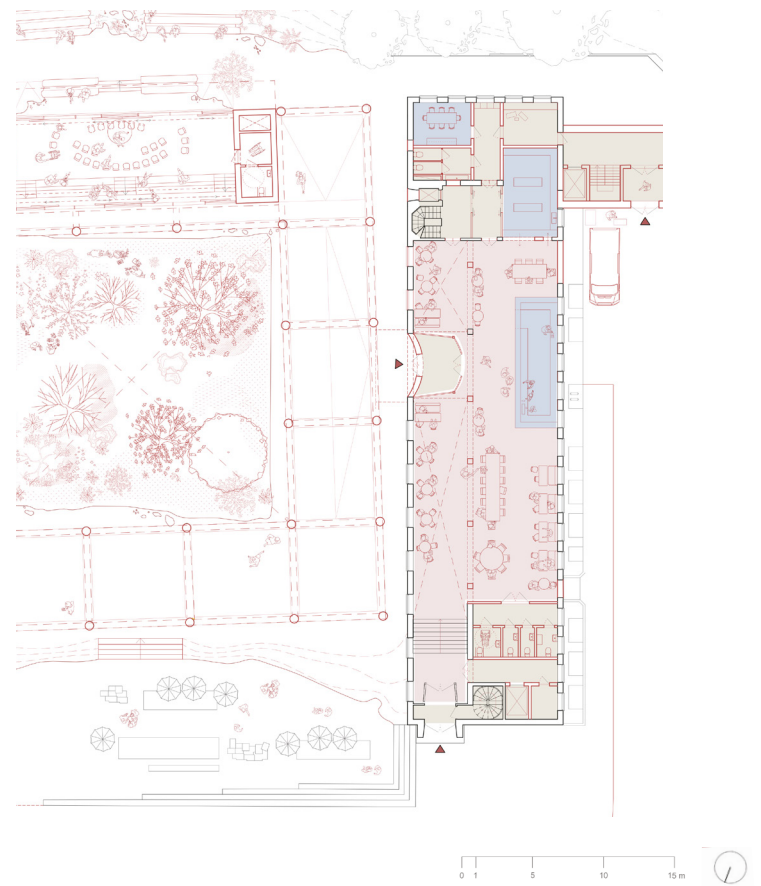

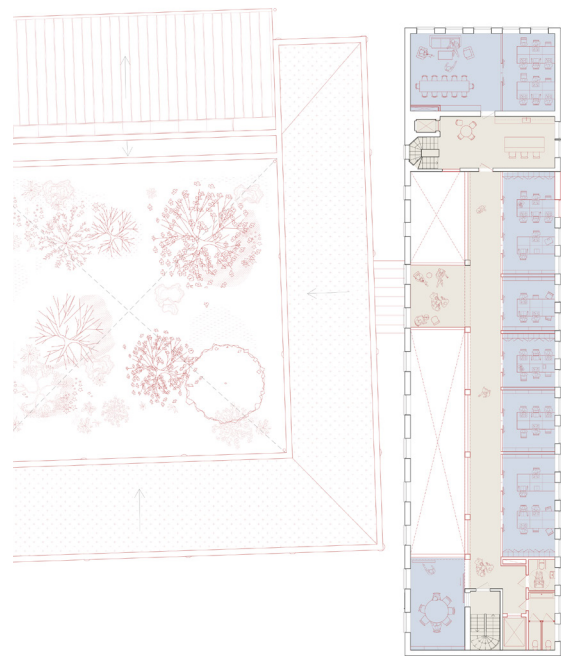

- Public
- Private
- Circulation



- Public
- Private
- Circulation

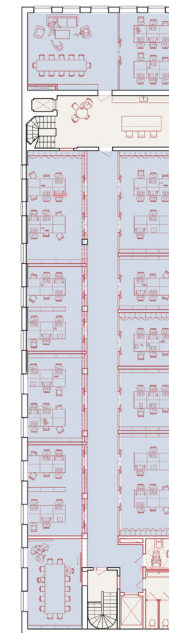

- Public
- Private
- Circulation

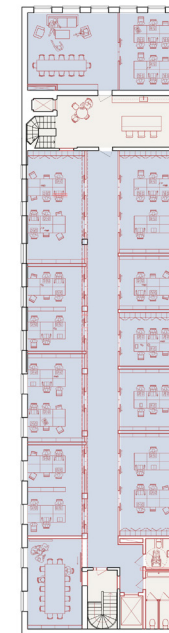



- Public
- Private
- Circulation

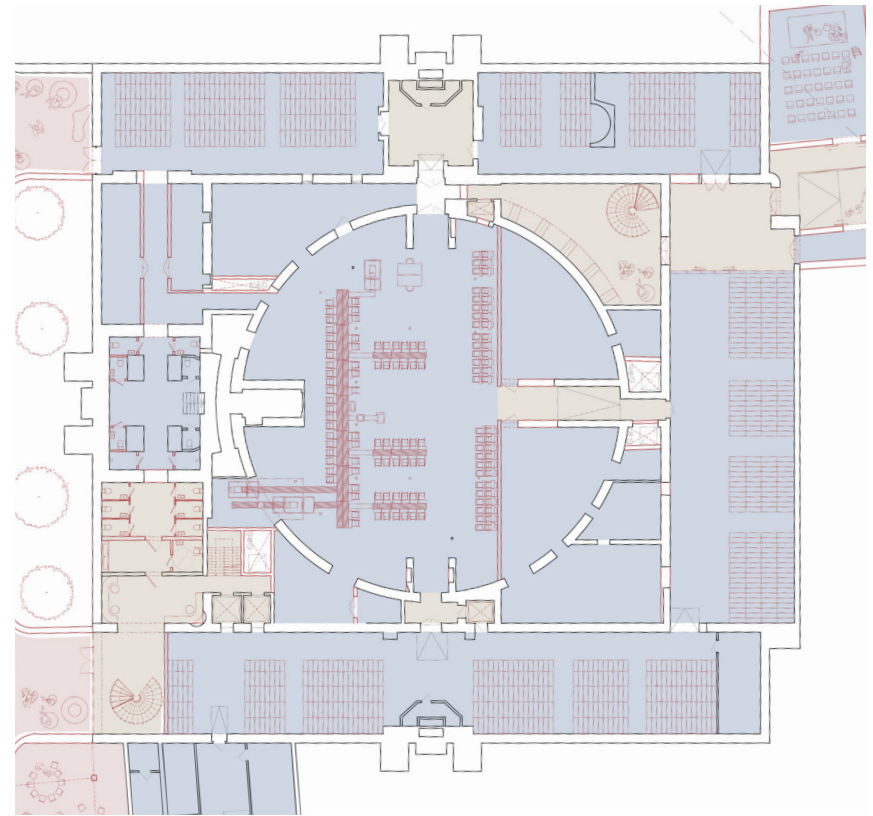

- Public
- Private
- Circulation

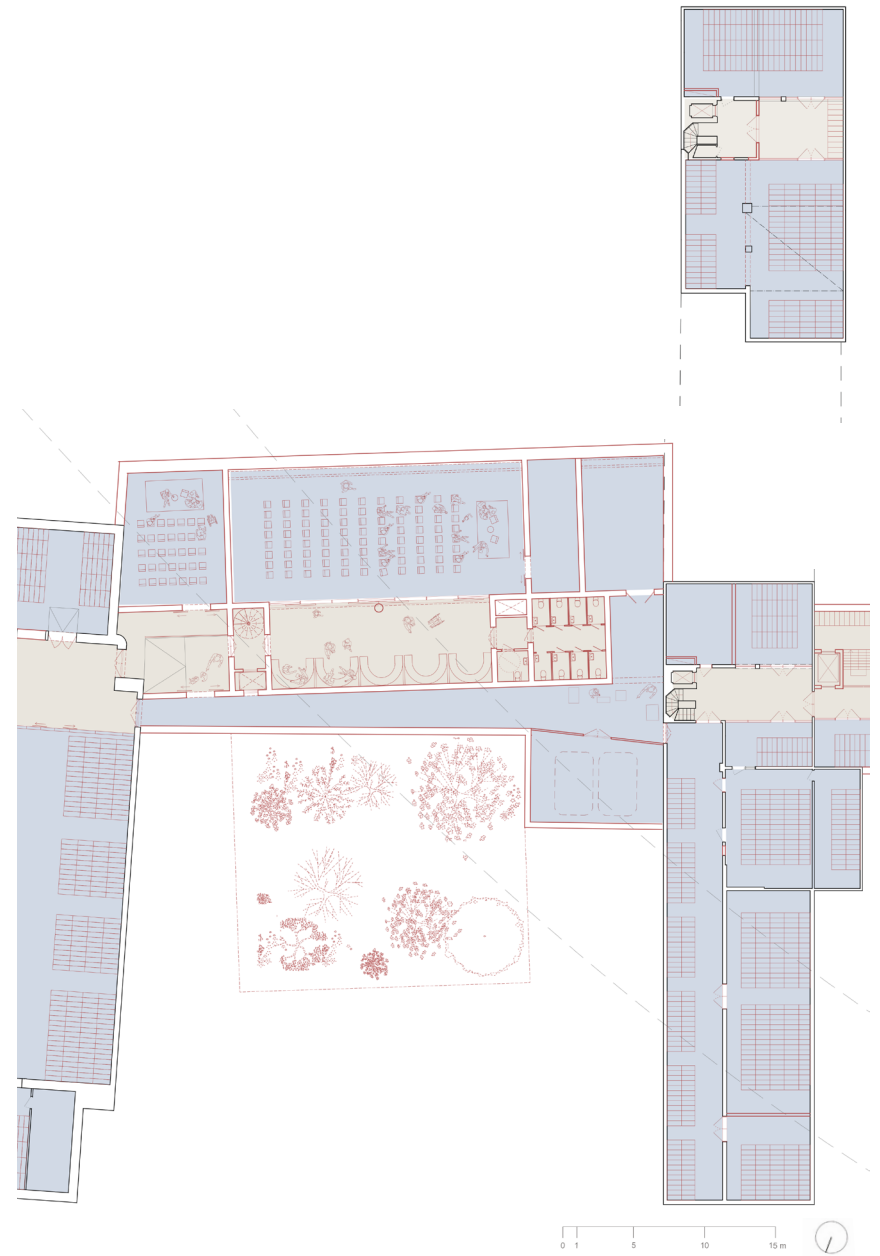

- Public
- Private
- Circulation

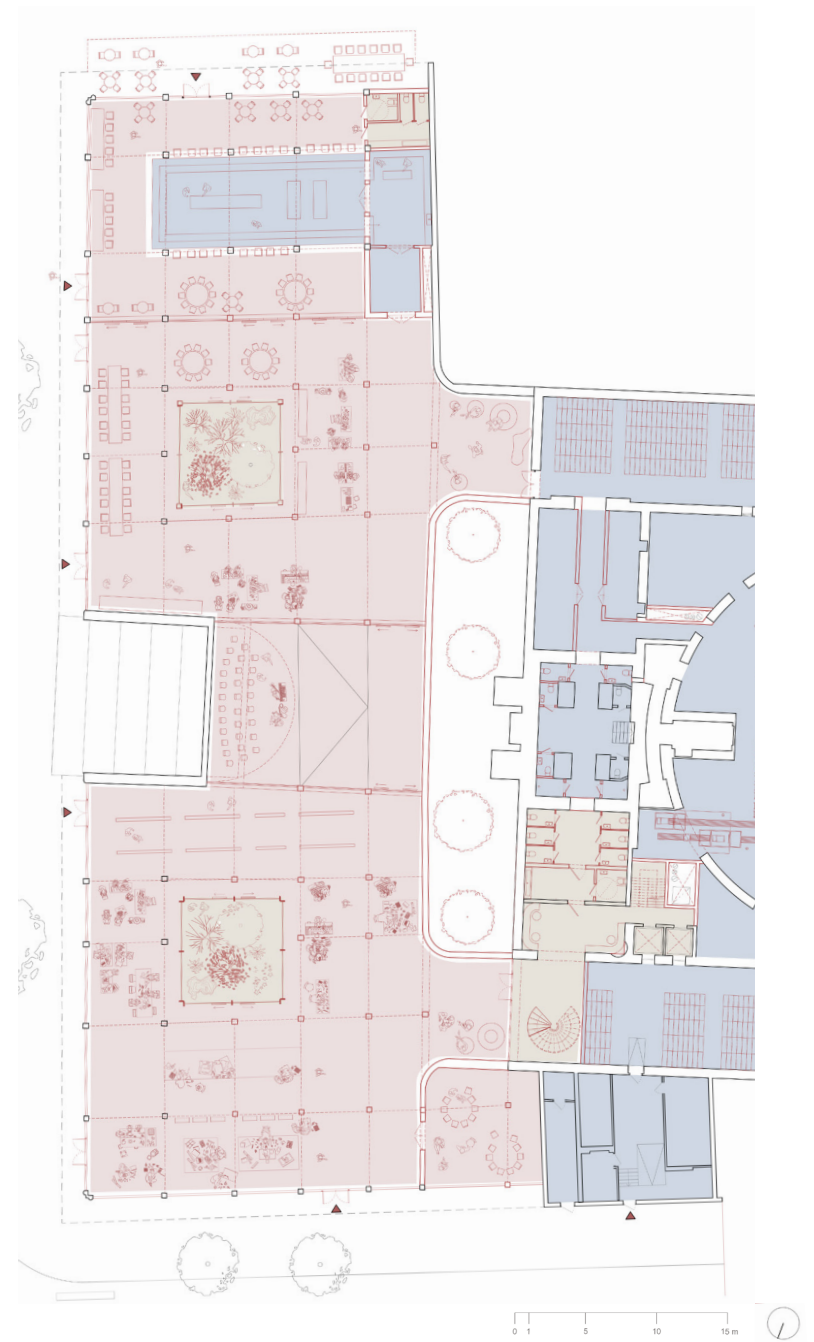

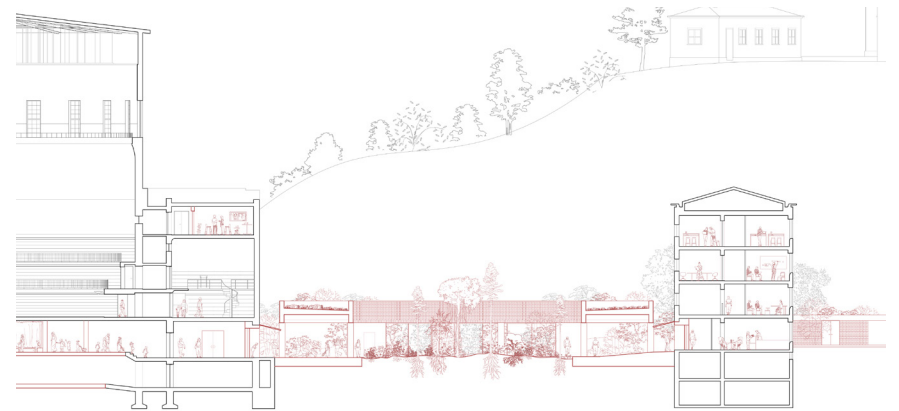

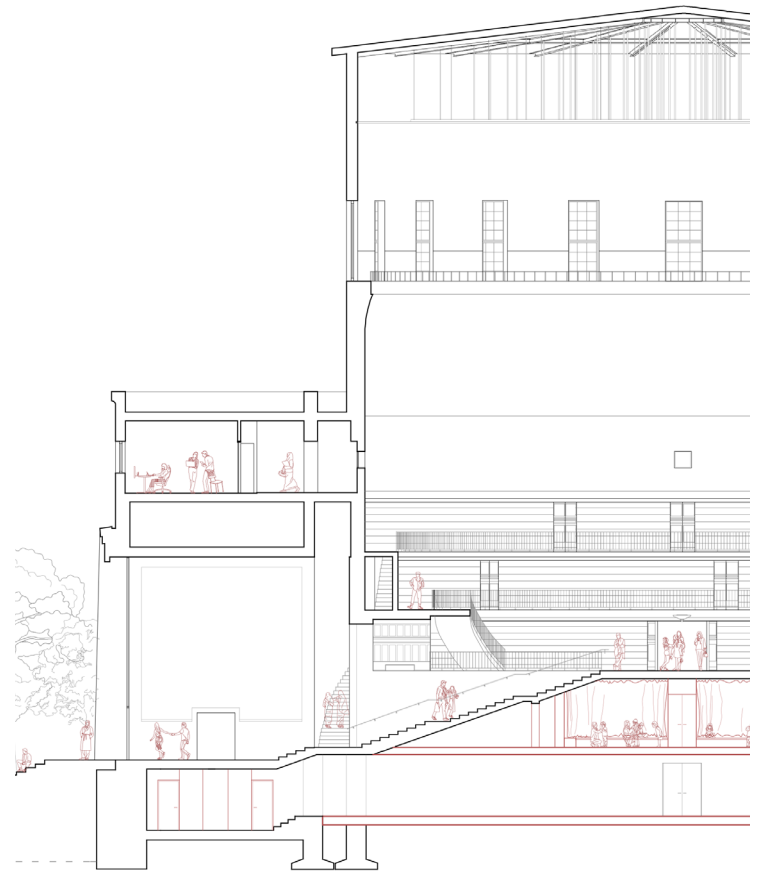
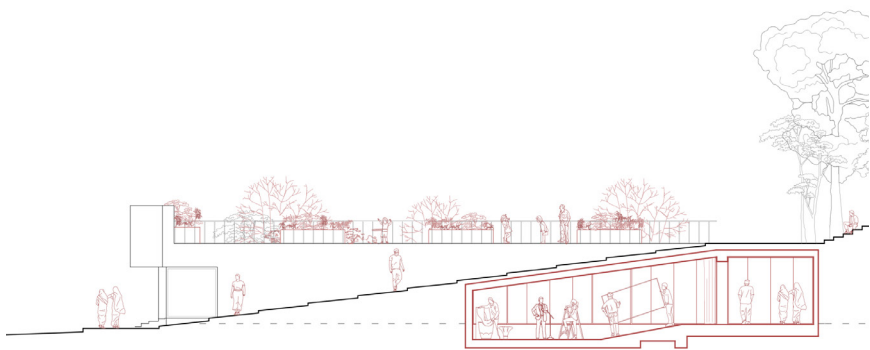



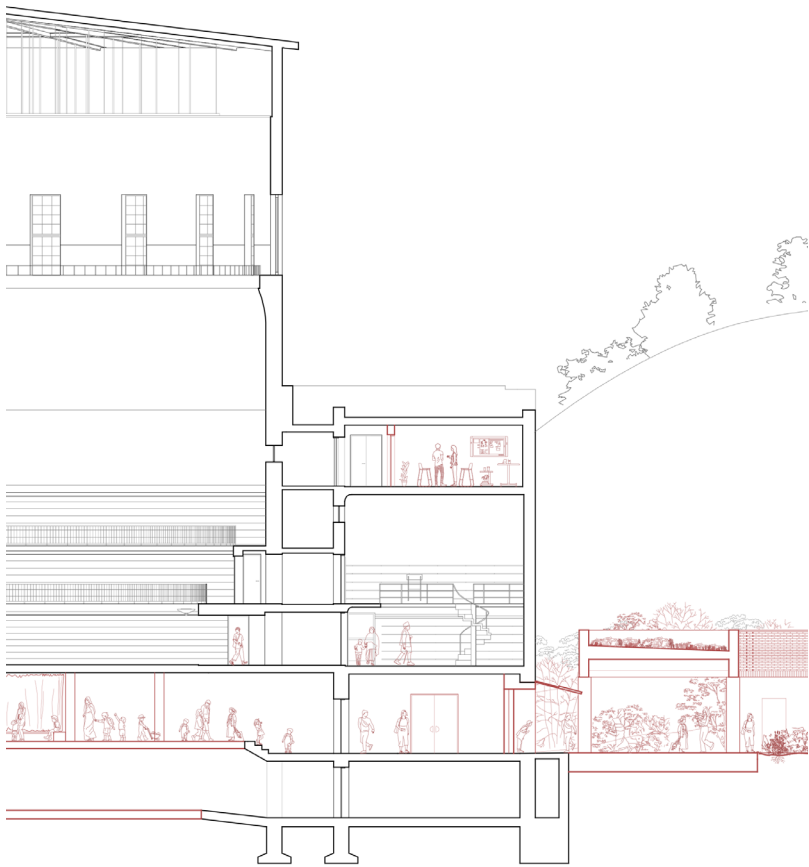

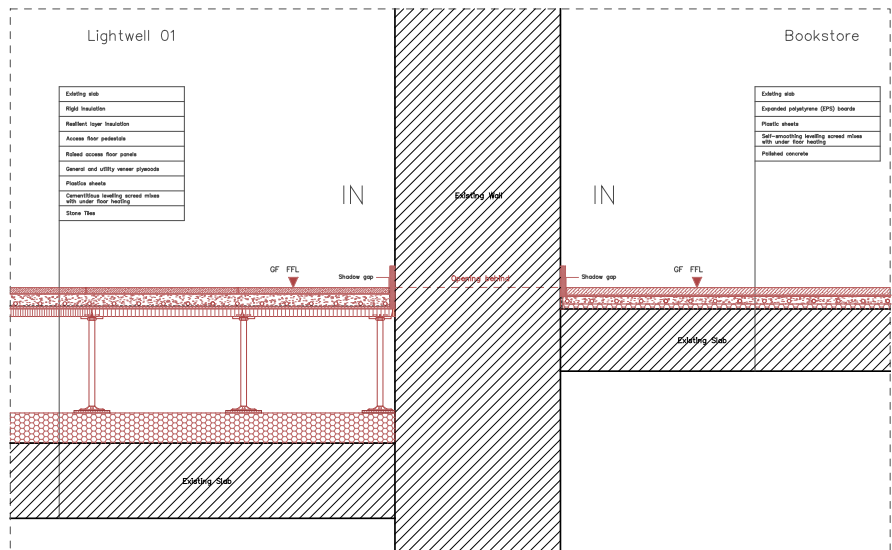

Lightwell 01

Bookstore

Existing wall
Rigid insulation
Reinforced concrete
Access floor panels
Raised access floor panels
General and utility veneer plywood
Plastic sheath
Dimensional leveling screed mixes with under floor heating
Stone tiles

Existing wall
Expanded polystyrene (EPS) boards
Plastic sheath
Self-levelling leveling screed mixes with under floor heating
Polished concrete

0 0.1 0.5 1 1.5 m

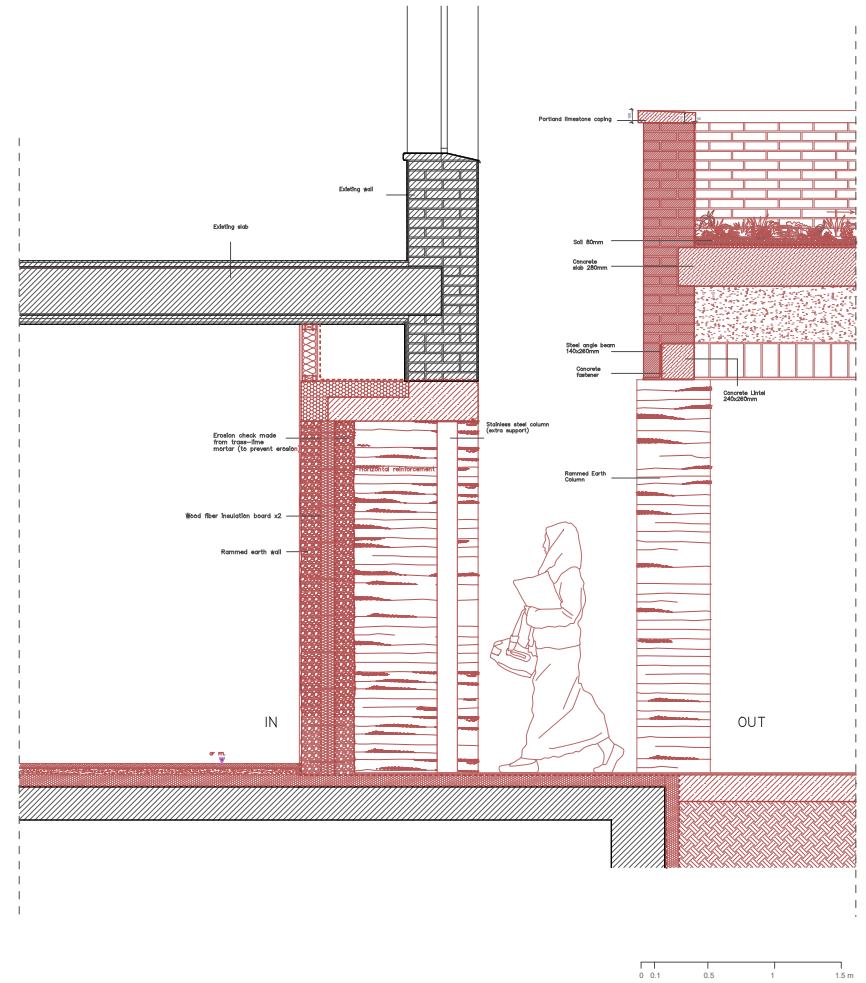

Existing wall

Existing slab

Erosion check made from three-time mortar (to prevent erosion)

Wood fiber insulation board x2

Rammed earth soil

IN

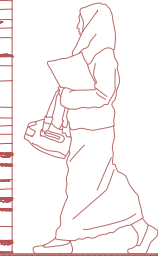

Galvanized steel column (extra support)

Rammed Earth Column

Concrete Lintel 240x250mm

Further limestone coping

Soil 80mm

Concrete slab 250mm

Steel angle beam 140x25mm

Concrete beam

OUT

0 0.1 0.5 1 1.5 m

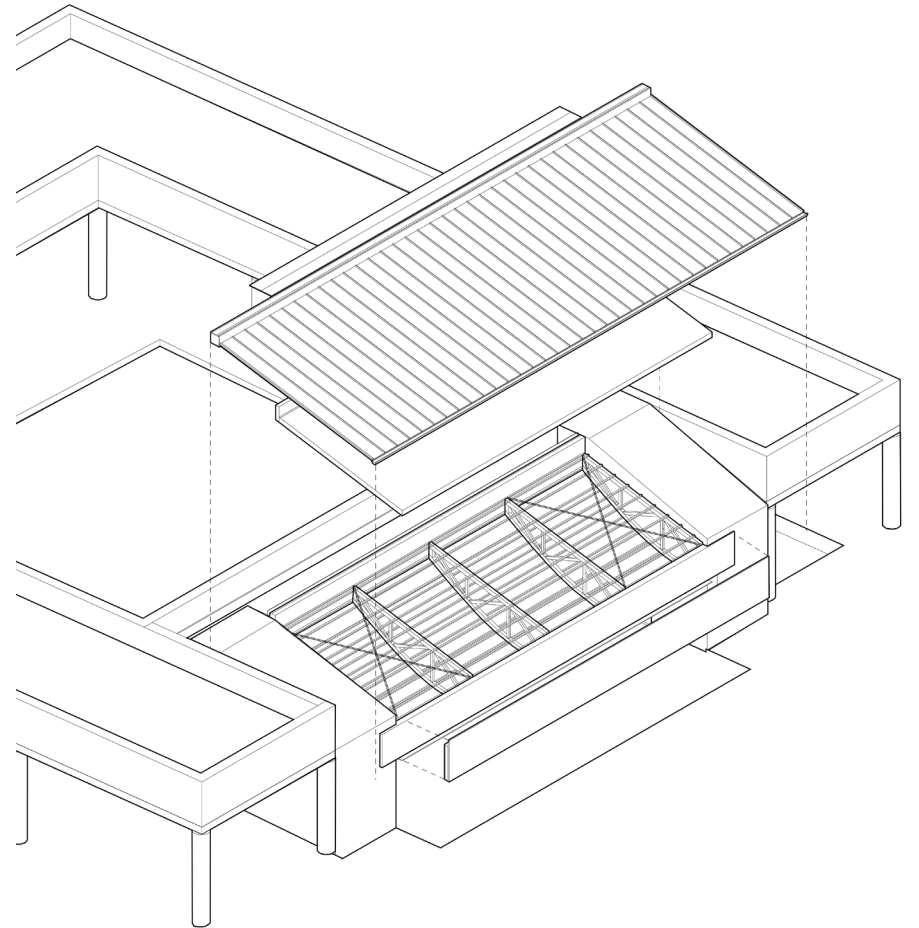

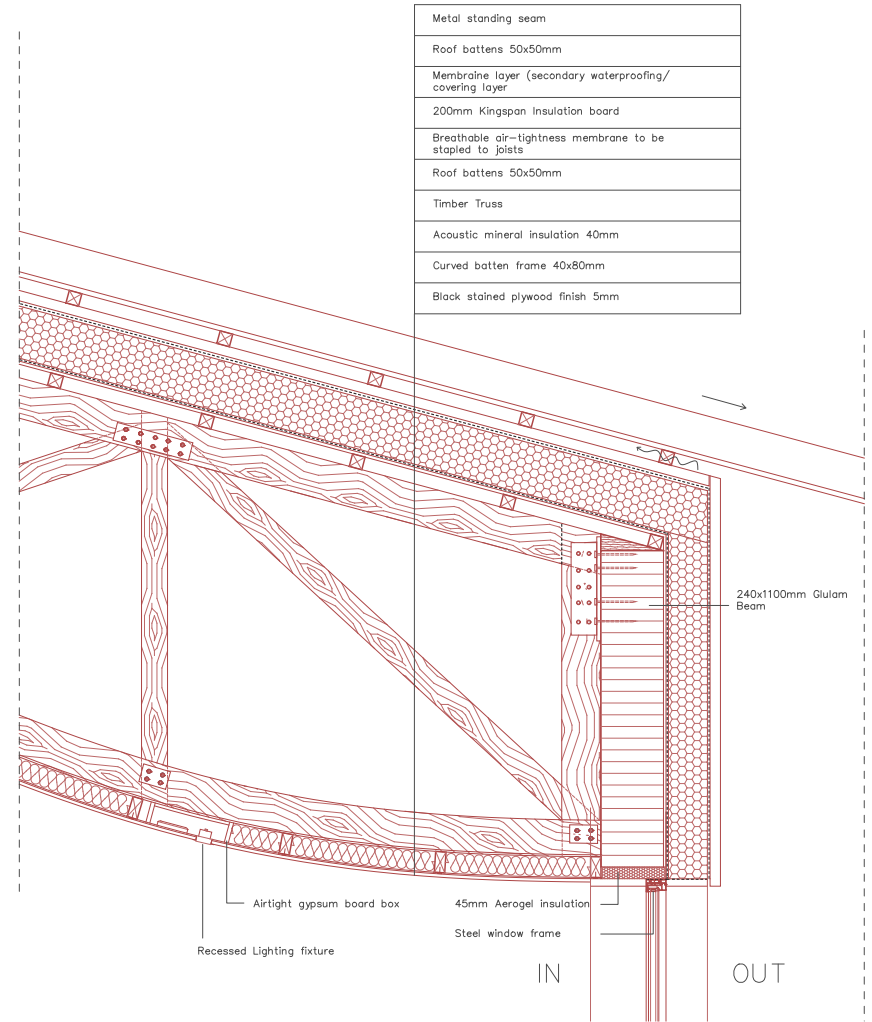
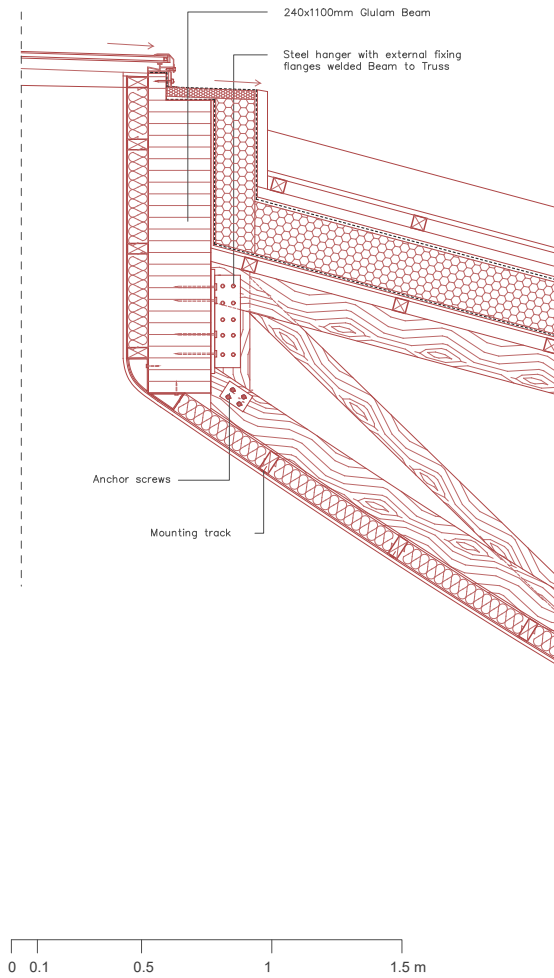

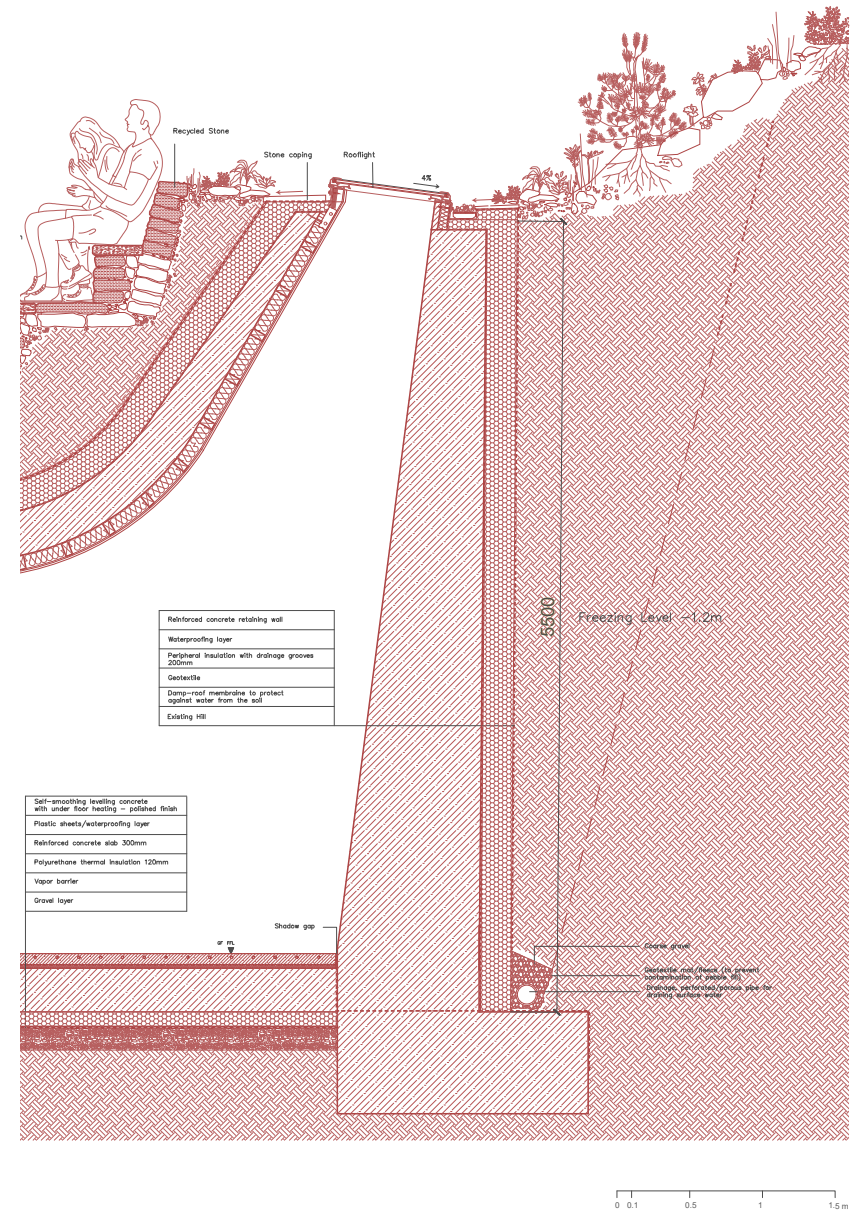
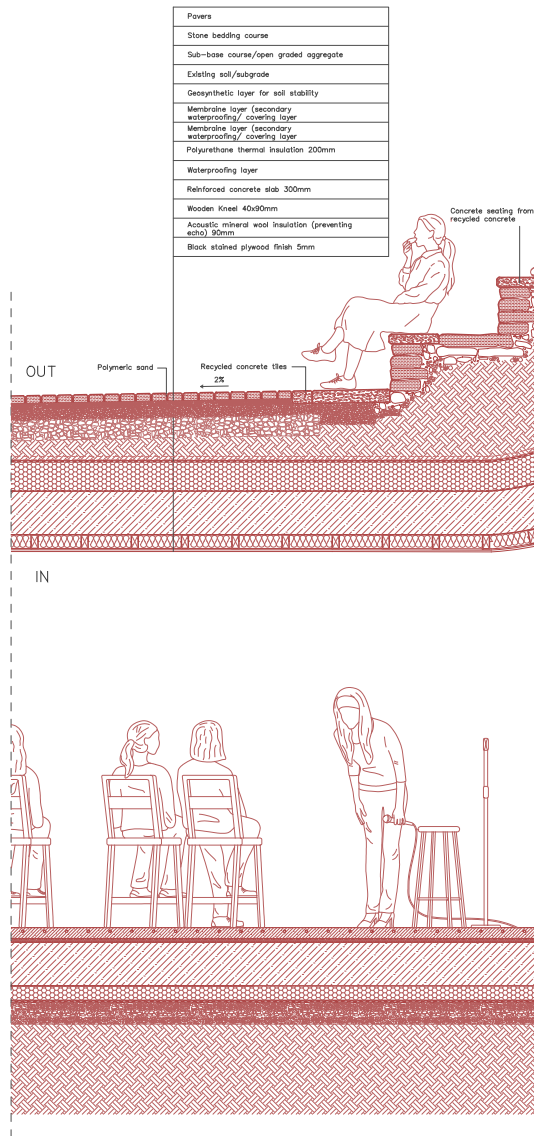











**The Montage of Voids**  
The Rotunda

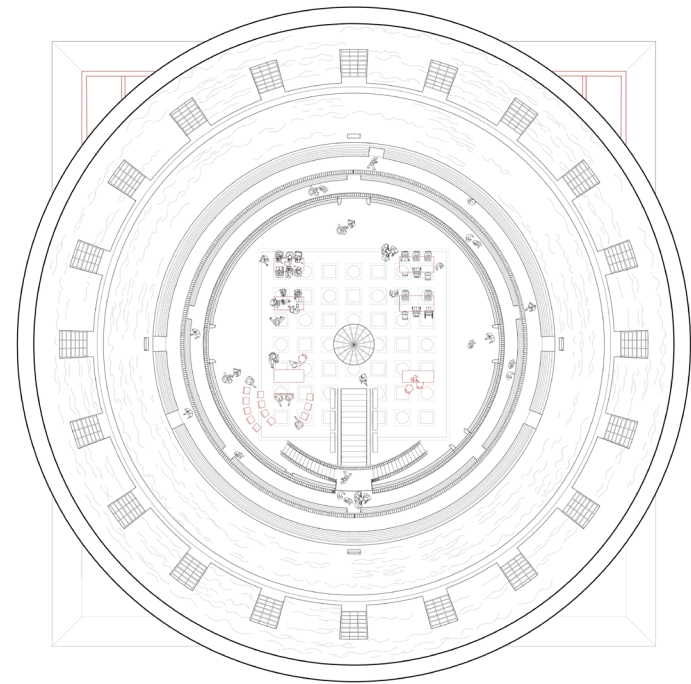

**The Montage of Voids**  
The Garden





**The Montage of Voids**  
The Bazaar Courtyard

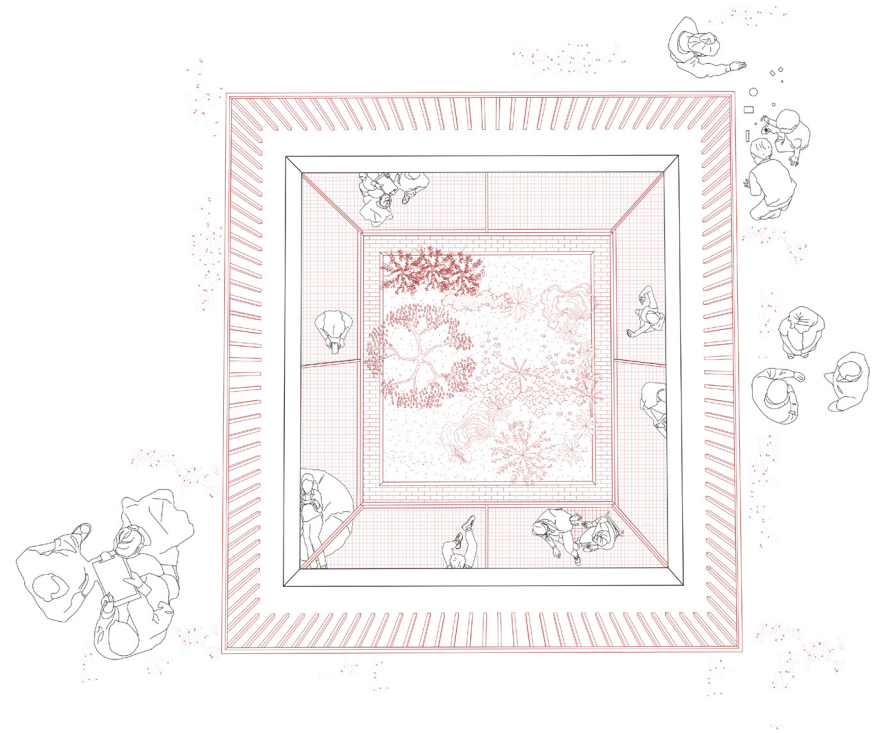

**The Montage of Voids**  
The Lightwells

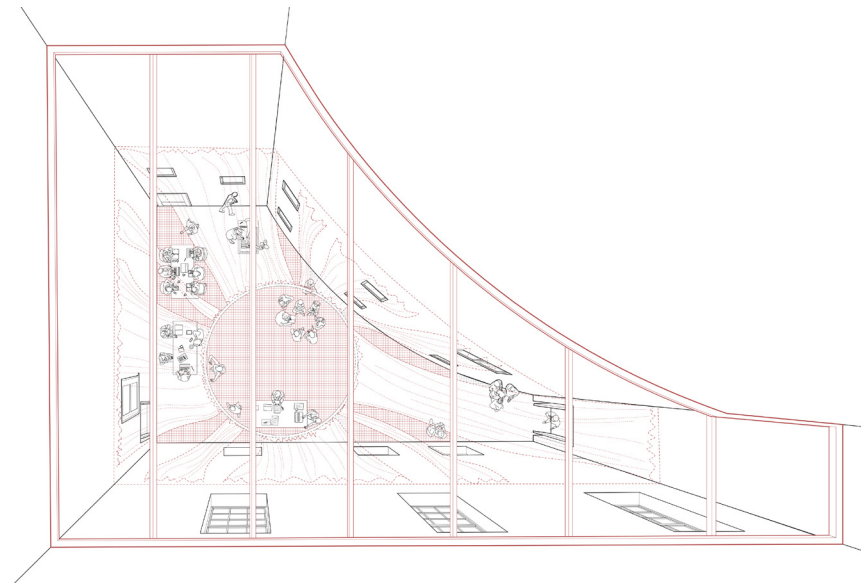

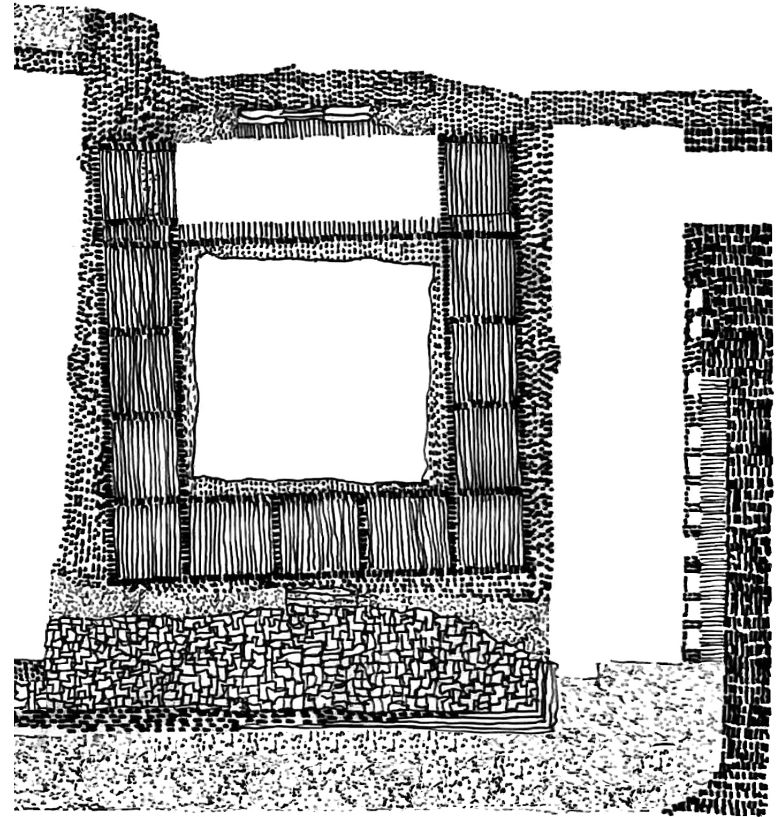
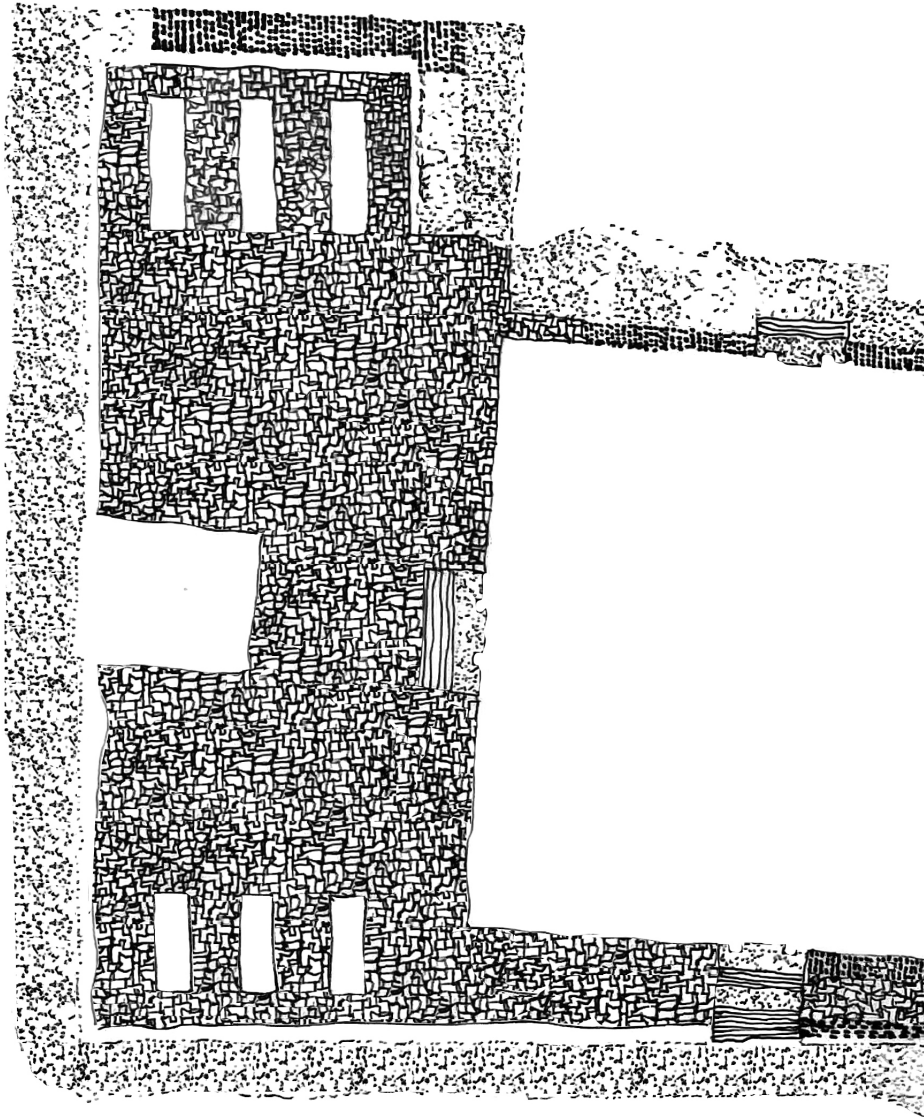









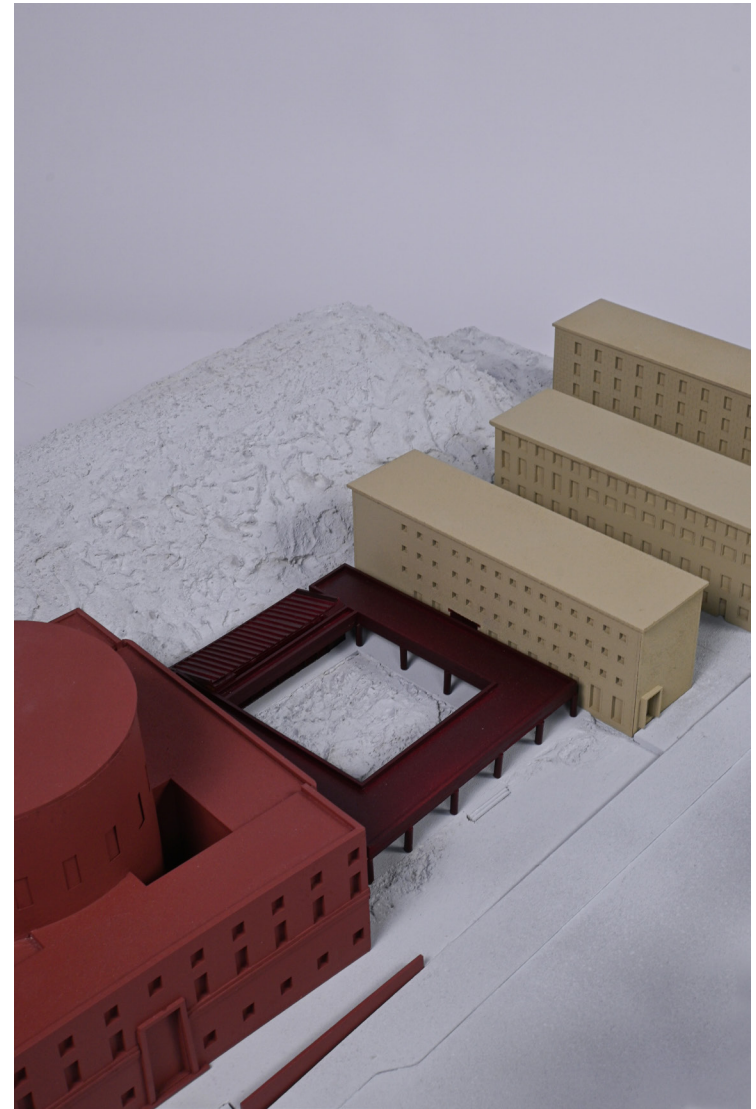

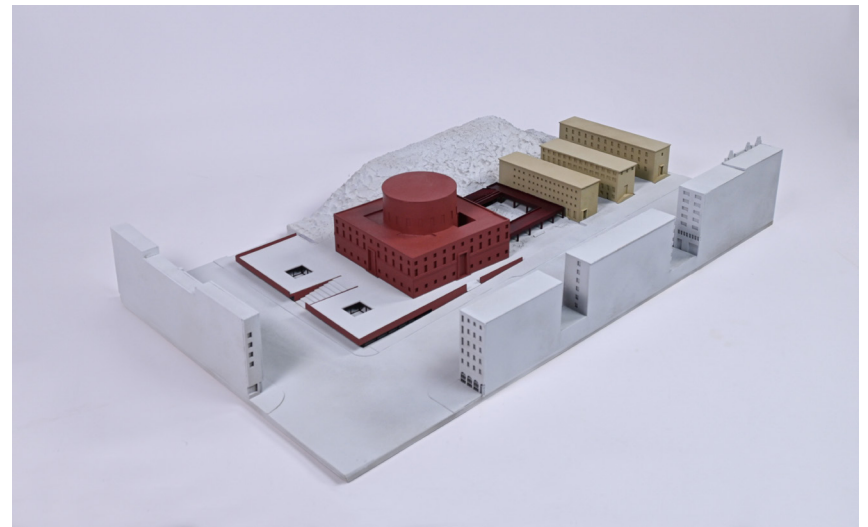
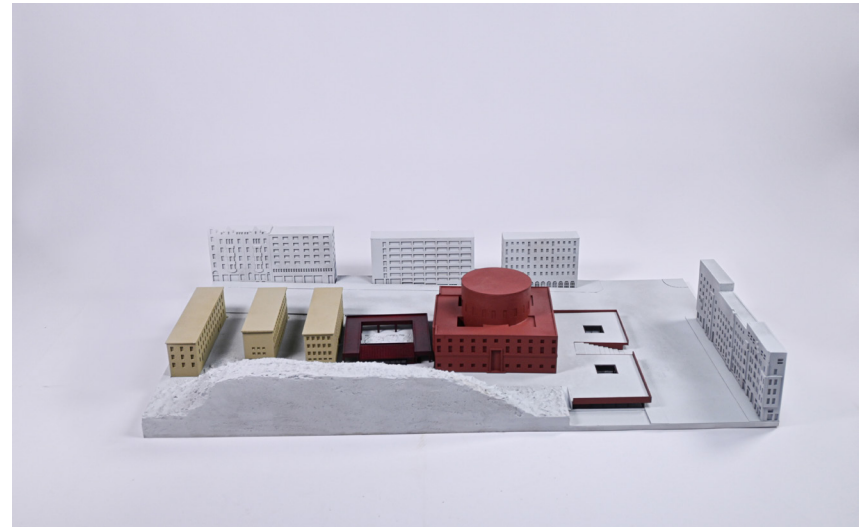















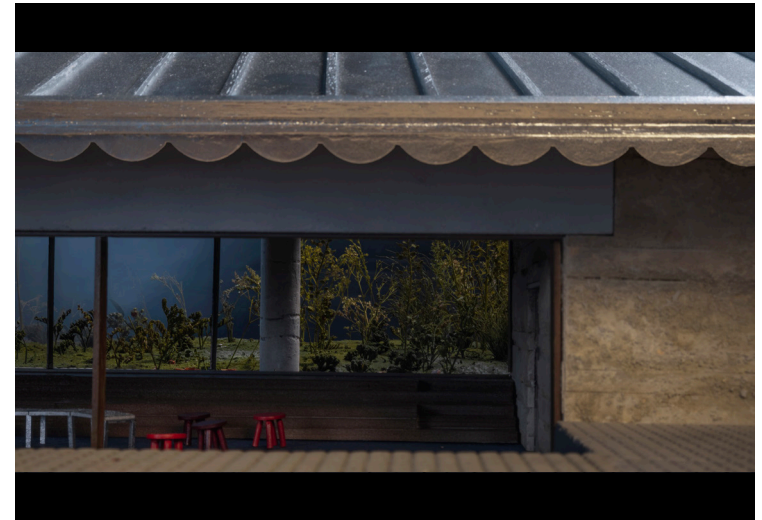



*Epilogue*





