

International Good Practices of Embankment Upgrading with Limited Footprint Increase

Poppema, D.W.; Voorendt, M.Z.; Mai Van, C.; Moll, J.R.; Jonkman, Sebastiaan N.; van der Scheer, P.; van Ledden, M.; Kazi, S.

Publication date

2023

Document Version

Final published version

Citation (APA)

Poppema, D. W., Voorendt, M. Z., Mai Van, C., Moll, J. R., Jonkman, S. N., van der Scheer, P., van Ledden, M., & Kazi, S. (2023). *International Good Practices of Embankment Upgrading with Limited Footprint Increase*. (Policy Research Working Paper Series). World Bank.

Important note

To cite this publication, please use the final published version (if applicable).
Please check the document version above.

Copyright

Other than for strictly personal use, it is not permitted to download, forward or distribute the text or part of it, without the consent of the author(s) and/or copyright holder(s), unless the work is under an open content license such as Creative Commons.

Takedown policy

Please contact us and provide details if you believe this document breaches copyrights.
We will remove access to the work immediately and investigate your claim.

POLICY RESEARCH WORKING PAPER

International Good Practices of Embankment Upgrading with Limited Footprint Increase

Daan Poppema

Mark Voorendt

Cong Mai Van

Roelof Moll

Bas Jonkman

Peter van der Scheer

Mathijs van Ledden

Swarna Kazi

November 2023

Abstract

This report investigates how embankments in Bangladesh could be upgraded with no or limited footprint increase. Many Bangladesh embankments need to be upgraded to improve flood protection. Traditionally, embankments are upgraded by adding more soil, heightening the crests while simultaneously widening the embankment maintain slope stability.

However, in many cases there is insufficient space for embankment widening. Case studies show that in Bangladesh, private assets often directly border embankments at both the landward and seaward side. Also land is scarce in general and the land directly adjacent to embankments is often in use by the communities. For traditional embankment heightening and widening, these buildings need to be (re)moved. So owners of private assets and land need to be identified and compensated and the land must be acquired leading additional project costs and delays.

This problem could be mitigated by using embankment upgrade techniques with a limited footprint increase. This requires knowledge of the available techniques and their suitability in the Bangladesh situation. Therefore, this study aims to provide an inventory of low-footprint embankment upgrade techniques used around the world, their (dis)advantages in terms of land use, risks, costs and O&M aspects, and their suitability for the situation in Bangladesh.

The most promising solution is placing underground sheet piles or concrete walls in the embankment body near the inner toe,

allowing for a steeper slope and hence increasing only embankment height, not width. Alternatively, floodwalls can be used to directly add embankment height. Potentially floodwalls allow to increase embankment height even more, independent of existing slope geometry. However, they severely limit traffic that needs to cross or exit embankments, which is near ubiquitous in Bangladesh. As widespread construction of gates is not recommended for the associated construction costs, maintenance costs and risks of gates not closing, floodwalls are best used where access to both embankment sides is not essential. Moreover, future upgrades to floodwalls are much more difficult than for embankments with underground sheet piles.

For both underground sheet piles and floodwalls, their stability forms a risk, especially under extreme conditions. Care should be taken to design a robust foundation and cover, such that wave overtopping will not result in progressive erosion, loss of structural stability and embankment breaching. Construction costs are substantial, in the USA and Europe typically 2-3 times the costs of traditional earthen embankments. In Bangladesh, the relative difference is likely even larger, given a larger importance of (hard) material costs over labour. Annual O&M costs vary, usually between 0.01% and 1%. For implementation, these costs need to be weighted per case against the benefits and cost savings from reduced landowner compensation costs, resettlement expenditures and project delays.

The Policy Research Working Paper Series disseminates the findings of work in progress to encourage the exchange of ideas about development issues. An objective of the series is to get the findings out quickly, even if the presentations are less than fully polished. The papers carry the names of the authors and should be cited accordingly. The findings, interpretations, and conclusions expressed in this paper are entirely those of the authors. They do not necessarily represent the views of World Bank and its affiliated organizations, or those of the Executive Directors of the World Bank or the governments they represent.

International Good Practices on Embankment Upgrading with Limited Footprint Increase

Daan Poppema

Mark Voorendt

Cong Mai Van

Roelof Moll

Bas Jonkman

Peter van der Scheer

Swarna Kazi

Mathijs van Ledden

This research was undertaken at Delft University of Technology within the contract number 7209077.

Table of Contents

Abstract.....	2
Table of Contents	4
1. Introduction.....	5
1.1. Problem analysis	5
1.2. Aim.....	6
1.3. Approach and reading guide	6
2. Site examples with footprint constraints.....	7
2.1. Embankment categories in Bangladesh.....	7
2.1 Sea embankment at Site A: Polder 48, Kuakata at the Bay of Bengal	8
2.2 Interior Embankment at Site B: Polder 33, Banishanta at the Pashur River	9
2.3 Marginal Embankment at Site C: Polder 5, at Akashlina Chuna Nodi river.....	10
2.4 Synthesis	11
3. Embankment upgrading techniques with limited footprint change	12
3.1. Embankment upgrade techniques for the foreshore	13
3.2. Embankment upgrade techniques at the outer slope	14
3.3. Embankment upgrade techniques at the dike crest	16
3.4. Embankment upgrade techniques at the inner slope	20
3.5. Techniques summary and selection.....	24
4. International example project 1: embankment reinforcement at Gorinchem-Waardenburg, The Netherlands.....	27
4.1. Description of the project.....	27
4.2. Current situation.....	28
4.3. Design and cost indications.....	29
4.3.1. General design choices.....	29
4.3.2. Total project costs	31
4.4. Additional option: allowing for multiple functions.....	32
4.5. Lessons for Bangladesh.....	33
5. International example project 2: Floodwalls in New Orleans	33
5.1. Flood protection in New Orleans	33
5.2. The West Return Floodwall	34
5.3. Alternative designs.....	35
5.4. Lessons for Bangladesh.....	36
6. Discussion and conclusions	36
7. References.....	37
Appendix A: Design choices in the Gorinchem-Waardenburg project.....	40

1. Introduction

1.1. Problem analysis

Bangladesh is one of the most densely populated countries of the world, located in a low-lying delta region where several of the world's largest rivers meet the Bay of Bengal. This makes Bangladesh extremely vulnerable to flooding, from cyclone-induced storm surges, monsoonal precipitation, and river floods from the Ganges, Brahmaputra, Meghna and a plethora of smaller rivers. Consequently, about 20 percent of Bangladesh experiences flooding in a typical year, reaching to more than 50 percent in extreme years (Mirza et al., 2001; Mutton & Haque, 2004). To provide protection against flooding and salt water intrusion, a large-scale embankment system was constructed in the 1960s, compartmentalizing the majority of the coastal region into polders.

Despite the protection offered by the embankment system and ongoing improvements to the system, flooding still occurs regularly, as a result of land subsidence, coastal and riverbank erosion, a lack of maintenance and the extreme hydraulic conditions that Bangladesh faces (Adnan et al., 2019; Steckler et al., 2022). The Coastal Embankment Improvement Project (CEIP) has upgraded embankments of 10 polders in Bangladesh and protect against storm surges and cyclone flooding with a recurrence time of 25 years. The first phase of this project, funded by the World Bank and implemented by the Bangladesh Water Development Board (BWDB), has been implemented between 2013 - 2023. In the meantime, the feasibility study for the next phase is ongoing (BWDB, 2022).

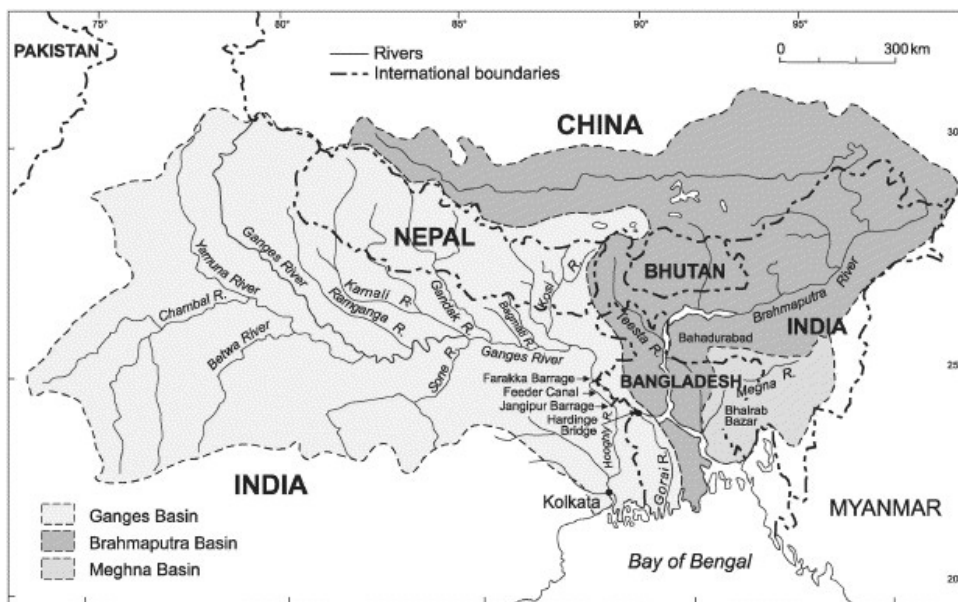

Figure 1: The location of Bangladesh at the Bay of Bengal and the confluence of three major river systems. Reprinted from Monirul Qader Mirza (2002, copyrighted), with permission from Elsevier.

For embankment improvement in the Bangladesh coastal zone, space availability is often limited. A road is usually situated at the embankment crest and houses are often build directly along embankments at the inner and outer toe, or even on the embankment slopes, attracted by the safety offered by building at a higher elevation, by the closeness to the road at the embankment crest or simply by the availability of land. And even if buildings are not present, land along embankments will be used by e.g. aquaculture. This seriously complicates embankment

upgrades. Embankments in Bangladesh are traditionally made using local clay, so the logical upgrade is to raise embankment height using more clay. To maintain soil stability, slopes cannot be too steep, so any embankment raised this way must be widened as well, increasing the embankment footprint. Further footprint increases occur due to the ambition at some dike rings to simultaneously widen the embankment crest and the road on top, in order to cope with population growth and increasing motorized traffic.

Land and building owners must be compensated before any footprint-increasing embankment upgrade can take place. However, a central land ownership administration is still in development, so it can be a long and arduous process to first determine the rightful owners and then come to agreement on the compensation needed. And by the loan terms of the World Bank, project construction can only start when all affected neighbouring landowners have been identified and compensated. Moreover, the land acquisition and building (de)construction or relocation cost money, making embankment upgrades more expensive. Overall, this leads to large delays and increased costs for embankment upgrade projects.

Embankment upgrading techniques with a limited spatial footprint, like floodwalls that add height without needing to widen the embankment, can likely help to reduce the implementation time, and possibly cost, of embankment improvement projects. However, such techniques have so far rarely been applied in Bangladesh, making it unclear which techniques are available and suitable for the local situation in Bangladesh.

1.2. Aim

Therefore, this study aims to provide an overview of international good practices in low-footprint embankment upgrading techniques, their (dis)advantages in terms of footprint, construction risks, costs and O&M aspects, and their suitability for the local situation in Bangladesh. To support the implementation of these techniques in local practice, techniques will be explained and detailed project examples and drawings will be shown.

1.3. Approach and reading guide

This report first characterizes the problem of footprint constraints around embankments in Bangladesh. Hereto a selection of representative sites with various embankment types is made, describing location, land usage, embankment characteristics and hydrodynamic boundary conditions (Chapter 2). Next, an inventory is made of embankment upgrade techniques used internationally with no or limited footprint increase (Chapter 3), providing information on e.g. targeted failure mechanisms, a techniques principle, typical materials, costs and other aspects of construction and maintenance. After this, two international projects are described as example of low-footprint embankment reinforcements, in the Netherlands (chapter 4) and the United States (chapter 5). Finally, implications and conclusions for spatially constrained embankment upgrades in Bangladesh are discussed (chapter 6).

2. Site examples with footprint constraints

2.1. Embankment categories in Bangladesh

Bangladesh has three main categories of embankments: sea embankments, interior embankments and marginal embankments:

- **Sea embankments** are located along the Bay of Bengal. They are exposed to open sea and need to withstand storm surges and high waves. Typical maximum water levels at a 25-year return period range from approximately 3-4 meters above Mean Sea Level in the west of Bangladesh up to 6-7 meters in the east (Islam et al., 2018; Van Berchum et al., 2020). Consequently, sea embankments must be dikes with substantial elevation and with mild slopes for macro-stability and usually outer slopes covered by revetments to prevent erosion under wave attacks.
- **Interior embankments** are located along the major tidal rivers, such as the Sibsha and Passur. These tidal river are multiple kilometres wide, so waves are still substantial (approximately 1 m high for a return period of 25 years) and surge levels can remain similar to those at the coast (Van Berchum et al., 2020).
- **Marginal embankments** are located along peripheral rivers, so the tributaries of the major tidal rivers. Given narrower rivers and generally lower waves, wave resistance becomes less critical, allowing for steeper embankment slopes at marginal embankment.

For all these type of embankments footprint constraints exist, but suitable solutions may differ, depending e.g. on the relative importance of waves and surge levels. The section below characterizes example sites of embankments with footprint constraints in more detail. The sites include all three embankment categories described above, and are selected based on having footprint constraints and being present in publicly available datasets such as Google Streetview. Together, they show that footprint constraints occur at all three embankment types, with villages or isolated buildings directly bordering embankments, at the inner slope as well as the outer slope. For river embankments, an additional argument against widening at the outer slope – towards the river – can be the resulting river narrowing, leading to a slight increase in water levels during peak discharges.



Figure 2: Three typical locations with embankment footprint constraints are examined, indicated by letters A-C (adapted from [Oona Räisänen](#), CC BY licence).

2.1 Sea embankment at Site A: Polder 48, Kuakata at the Bay of Bengal

Site A is the village of Kuakata in polder 48, situated in the very south of Bangladesh, directly bordering the Bay of Bengal (Figure 2). Its characteristics are described in Table 1 below. As shown in Figure 3, buildings located at the inner slope or occasionally at both sides of the embankment regularly limit the available space for embankment upgrades. Owing to the exposed location at the Bay of Bengal, stone revetments are regularly used to prevent wave erosion, especially at locations without a wide shallow foreshore.

Table 1: Embankment characteristics and footprint constraints at polder 48 in Bangladesh.

Polder 48	Embankment type: sea embankment
Location:	The village of Kuakata, in the south of Bangladesh, at the Bay of Bengal. Coordinates: 21.816°N, 90.121°E.
Embankment characteristics:	Clay embankment with an outer slope of approximately 1:6; inner slope 1:3. Crest covered by a gravel or asphalt road. Stone revetments applied where foreshore width is limited (Figure 3).
Footprint constraints:	Buildings at inner slope and occasionally at the outer slope and foreshore (Figure 3).
Hydraulic design conditions:	Significant wave height of 3.38 m, storm surge level of +3.49 mPWD (25-year return periods, Van Berchum et al., 2020).



Figure 3: Photos of the sea embankment of dike ring 48. Top left: The location of the embankment site, marked by the 'X'. Top right: the embankment covered with an asphalt road, with buildings present at both inner slope (left on photo) and outer slope (right). Bottom left: some buildings present at the inner slope, stone revetment at the outer slope. Bottom right: stone revetment with roughness elements at outer slope. Sources: Google Maps, Google Streetview

2.2 Interior Embankment at Site B: Polder 33, Banishanta at the Pashur River

Site B is the village of Banishanta at the Pashur River, situated a few kilometres to the north of the Sundarbans (Figure 4A). Its characteristics are described in Table 2 below. As shown in Figure 3, buildings placed at the inner slope or at both sides of the embankment limit the available space for embankment upgrades.

Table 2: Embankment characteristics and footprint constraints at polder 10-12 in Bangladesh.

Polder 33	Embankment type: sea embankment
Location:	The village of Banishanta at the Pashur River, 2 km north of the Sundarbans. Local river width: 1200 m. Coordinates: 22.459°N, 89.584°E
Embankment characteristics:	Inner slope of approximately 1:2; outer slope 1:3. Crest width of 4.5 m with gravel road.
Footprint constraints:	Buildings at the inner slope or toe, occasionally at the outer toe.
Hydraulic design conditions:	Wave height of 0.87 m. Storm surge: 2.92 m PWD (25-year return periods, Van Berchum et al., 2020).



Figure 4 A) The location of the embankment site (marked by the 'X'). B) An aerial photo of the village and harbour. Letters C and D indicate the location where photos in panel C and D are taken, with arrows for their view direction. C) Photo of the embankment, with a gravel road on top and buildings on both sides. River on the left. D) Idem, with river on the right. Sources: Google Maps; Google Earth, CNES, Airbus, Maxar Technologies; Google Streetview.

2.3 Marginal Embankment at Site C: Polder 5, at Akashlina Chuna Nodi river

Site C is the village of Nakashlina at a peripheral river called the Chuna Nodi, a tributary of the Kholpetua River. Its characteristics are described in Table 3 below. Buildings directly border the embankment at both sides (Figure 5). In addition, the landward side of the embankment is bordered by aquaculture ponds.

Table 3: Embankment characteristics and footprint constraints at polder 10-12 in Bangladesh.

Polder 33	Embankment type: sea embankment
Location:	The village of Nakashlina at the Chuna Nodi River, 2 km north of the Sundarbans. Local river width: 200 m. Coordinates: 22.265°N, 89.194°E.
Embankment characteristics:	Inner slope of approximately 1:2, outer slope 1:3. Crest width of 4.5 m with gravel road.
Footprint constraints:	Buildings and aquaculture at the inner embankment toe, buildings at the outer toe.



Figure 5 A) The location of the embankment site (marked by the 'X'). B) An aerial photo of the site. Letter C indicate where the photos in panel C is taken, with the arrow for the view direction. C) Photo of the embankment (gravel road), with buildings at both sides. Water at the left of the road is an aquaculture pond, at the top right is the river. Sources: Google Maps; Google Earth, CNES, Airbus, Maxar Technologies; Google Streetview.

2.4 Synthesis

Overall, the examples show that space constraints for dike upgrading are present at all three embankment types. The main constraint is buildings being present at *both* sides or embankments, at the toe of the embankment or even on the embankment slope. Main issues here are land acquisition, the identification and compensation of (official) owners, resettlement of inhabitants and deconstruction of buildings. Next, all examined embankments are also used as roads. People use embankments intensively for traffic, traveling *along* embankments, but also nearly everywhere *crossing* or exiting embankments for access to houses at either side, fishing or cattle crossings. So any embankment upgrades should allow for this traffic.

3. Embankment upgrading techniques with limited footprint change

This chapter presents an inventory of embankment upgrade techniques with a limited spatial footprint. Techniques are ordered by the embankment part targeted, as a techniques' suitability depends on its physical location (foreshore, embankment crest, etc) compared to the spatial footprint constraints around an embankment. An overview of the covered techniques is given in Figure 6.

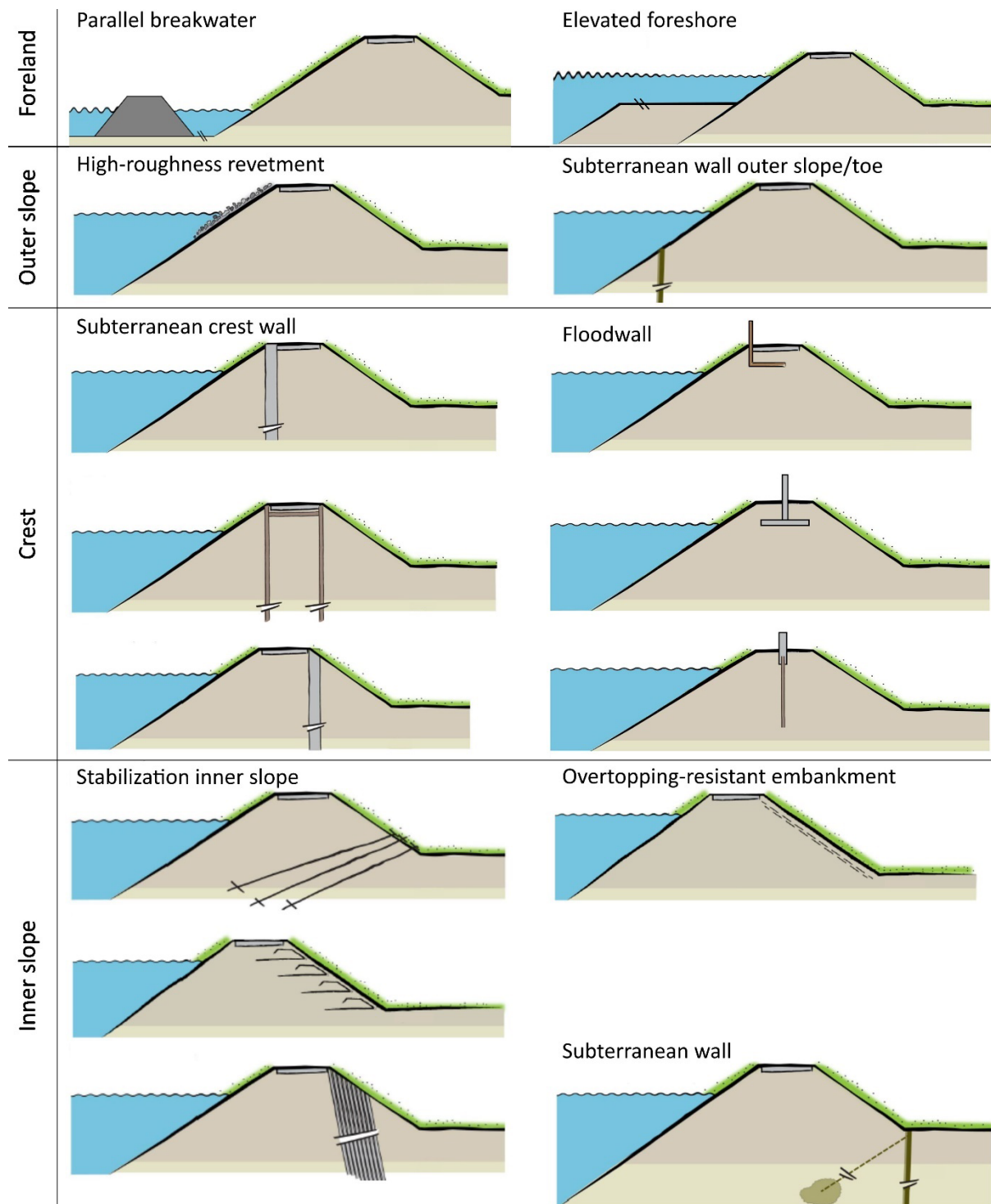

Figure 6: Overview of possible embankment upgrade techniques with limited or no footprint increase. Adapted from RHDHV (2016)

3.1. Embankment upgrade techniques for the foreshore

There are several embankment upgrade techniques that take place in the foreshore. While these techniques do not necessarily have a low spatial footprint, they can offer a solution in situations where the direct surroundings of an embankment are occupied by e.g. buildings, but space is available further in front of the embankment. These techniques primarily decrease flood risk by dampening waves before they reach the embankment. This in turn reduces wave run-up, wave overtopping and erosion at the embankment's sea side. Examples of these techniques are detached breakwaters or nourishing of the foreshore.

Detached breakwaters

A parallel or detached breakwater is a structure parallel to the coastline, mainly built to protect the shore from wave attack and wave-induced erosion. They may be built as a single continuous structure or with gaps in between (segmented), and submerged (crest below MSL, see Figure 7) or emerged (crest above MSL). Typically they are made from stones, although concrete breakwaters also exist. In general, parallel breakwaters are constructed in order to decrease wave attack and alongshore sediment transport at sandy coasts (Bosboom & Stive, 2023). However, they can also serve to improve the safety level of embankments: by reducing wave height, wave runup and wave erosion in their lee. For this purpose emerged breakwaters are advisable: breakwaters that are already submerged during daily conditions would be so far submerged during a storm surge, that storm waves easily pass over the breakwater (Bosboom & Stive, 2023).

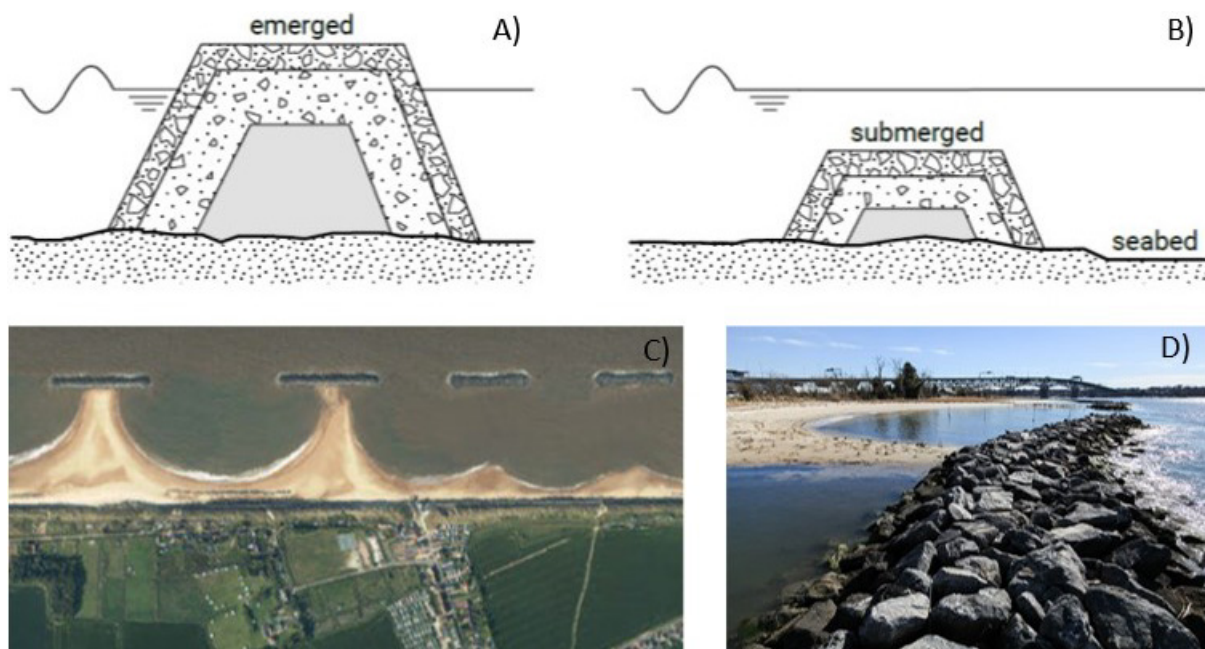

Figure 7 Shore-parallel breakwaters. A) and B) A cross-sectional sketch of submerged and emerged breakwaters. Not to scale: slopes are too steep. (Bosboom & Stive, 2023, CC BY NC SA licence) C) A group of segmented breakwaters in Sea Palling, England, aerial photo from UK Environmental Agency (Bosboom & Stive, 2023, Open Government Licence). C) A breakwater at the Chesapeake Bay, USA (source: [Chesapeake Bay Program](#), CC BY NC licence).

Even when built to dampen waves and increase embankment safety, breakwater effects on sediment transport and coastal morphology should still be taken into account. The wave reduction behind emerged breakwaters reduces wave erosion and wave-induced alongshore sediment transport, creating local deposition. This deposition can eventually reach the breakwater, creating a so-called tombola (Figure 7C). For segmented breakwaters, shoreline erosion may occur

behind the gaps, especially if the gap length is large compared to the breakwater length. Also, by sediment balance, deposition behind breakwaters usually leads to downstream erosion. Typical breakwater costs are \$1.4-6 million/km for Europe and the USA and 0.14-0.5 million for developing countries (Aerts, 2018, for waterdepth < 2 m and at 2016 cost level) and annual O&M costs for rubble mount breakwaters range from 0.01% to 1% of the initial investment (Aerts, 2018).

Elevated foreshore

Elevated land in front an embankment dampens waves, improving water safety (Lieberman & Mai, 2001). In addition, the land forms an extra buffer against erosion, for instance in case of meandering rivers where the channel is migrating towards an embankment. Accordingly, raising the foreshore can help to improve coastal safety. Given the large amount of sediment needed to do so, this is especially suitable for cases where large amounts of sediment are available, for example due to dredging. Alternatively, mangrove forests have the potential to naturally trap sediment, with the additional advantage that the trees and roots provide further wave breaking and increase soil stability (Dasgupta et al., 2014; Hashim & Catherine, 2013).

An alternative option to achieve an elevated foreshore can actually be to move the embankment inland (managed realignment). While this costs space (or at least protected space), it may actually be more cost-effective. Erosion protection can form a large part of embankment upgrade costs in Bangladesh. So even though embankment relocation requires compensating land owners and building a new embankment, the savings from needing less erosion protection may overall decrease project expenditures. However, this is much more likely for cases where agricultural land would be de-poldered, rather than the space-constrained cases with buildings that are the topic of this report. Even then, it would likely face strong societal backlash, as land scarcity in Bangladesh means giving up land is usually not perceived as an option.

3.2. Embankment upgrade techniques at the outer slope

Several embankment upgrade techniques take place at the outer slope. These techniques are usually geared towards reducing wave runup and overtopping, or toward increasing geotechnical stability to prevent slope instability.

High-roughness revetments

Revetments serve in the first place as a hard layer to prevent wave erosion at embankments, applied when the soil body itself or its grass cover is insufficiently erosion-resistant. In addition, smart selection of revetment shape and material can reduce wave runup and overtopping. This effect is caused by both the actual roughness of revetment layer, and its permeability. A higher roughness, or skin friction, reduces wave runup though flow resistance. In addition, higher revetment permeability allows a wave to penetrate into the voids of a revetment, reducing wave runup.

Many types of rough revetments are possible (Figure 8). Typical options are natural basalt columns, natural stones (riprap), open asphalt, specially shaped concrete blocks (tetrapod, Xblock, Hydroblock, Hillblock, Basalton etc.) or staggered placement of smooth concrete blocks. For e.g. riprap rock armour, unit costs are approximately \$0.3-0.8 million/km, with annual maintenance at 2%-4% of the initial investment (Aerts, 2018, based on UK projects and at 2016 price level).



Figure 8: High-roughness revetments. A) Rock armour revetment in Hampton-on-Sea, England (photo by [Storve book](#), CC BY licence). B) A revetment from concrete tetrapod elements in Mumbai (photo by [Kelisi](#), CC BY SA licence). C) A revetment with checkerboard roughness pattern at the Padma river in Bangladesh (adapted from Asaduzzaman; Wang, 2020). D) Checkerboard roughness created with concrete Basalton columns at the Hondsbossche Zeewering, The Netherlands (Jonkman et al., 2021). E) Erosion protection on the outer slope of a river embankment under construction near Ammerstol, Netherlands.

Subterranean wall at outer slope

If high water level occurs at an embankment for extended periods, such as with river floods, then this water slowly infiltrates the embankment, saturating the soil. When the water level suddenly drops, excess pore pressure without counterpressure from the water can lead to slope failure through a slip circle at the outer slope. For embankments where this macro-instability of the outer slope is an issue, subterranean walls can be used to stabilize the embankment. These walls can be made as reinforced concrete wall or as steel sheet pile. Concrete walls are

usually cast in place with steel reinforcement, also called diaphragm wall or slurry wall. By installing these walls through the expected slip circle into the stable subsurface at the outer slope, the slip circle can be prevented (Figure 9). In case expected horizontal forces on the wall are too high, soil anchors can be used to resist the sideward forces. For embankments that are geotechnically stable but too low, the same solutions can be used to increase outer slope steepness without running into slope stability issues, thereby allowing to raise the crest without increasing the embankment footprint.

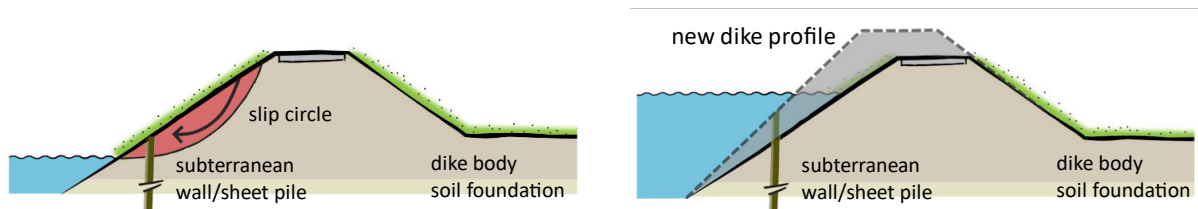

Figure 9: Sheet pile or a subterranean walls can be used to stabilize the outer slope, thereby preventing outer slope instability for embankments already at risk (left) or allowing for a steeper outer slope and hence crest heightening without footprint increase (right). Adapted from RHDHV (2016)

3.3. Embankment upgrade techniques at the dike crest

Floodwall/crown wall on embankment crest

Floodwalls on top of an embankment, also referred to as crown walls, are a classic way to improve embankments that are at risk of failure due to insufficient height. There are multiple variants, using steel sheet piles or concrete elements in purely vertical, L or T shape. When using floodwalls, care should be taken that both the floodwall itself and the embankment body are stable. For the floodwall, this means it should withstand surge levels and wave impacts, with a foundation protected from erosion, such that any wave impact or overtopping cannot create progressive scour resulting in failure. In addition, piping under the floodwall should be prevented, e.g. by using an impermeable sheet pile wall as foundation. For the embankment body itself, geotechnical stability should also be considered, lest additional loads by the floodwall cause sliding of the outer or inner slope or shearing of the embankment.

There are multiple floodwall variants (Figure 10, Figure 11), often named after their cross sectional shape. I-walls have a purely vertical structure, usually consisting of steel sheet pile and possibly capped by a concrete plinth. T-walls and L-walls consist of concrete elements with a horizontal base for extra stability. Usually, their base is connected to underground sheet piles and to angled concrete or steel foundation piles. The sheet piles fulfil a dual purpose, acting both as an foundation and as a screen against seepage.

During Hurricane Katrina in New Orleans, T-walls performed better than the sheet pile I-walls: several breaches occurred in the I-wall sections after foundation failures induced by the formation of a gap along the outside of the floodwall (USACE, 2006). Based on these events, new US Army Corps of Engineers guidelines (USACE, 2012) recommend to limit I-wall height to 1.2 m above the embankment body at the protected side of the wall, and at most 0.6 m more at the floodside. For higher floodwalls, L-walls (up to 2.4m) or T-walls (no height limit) are recommended, as their base slab and more extensive foundation impart better stability. Conversely, T-walls are typically not used for heights below 1.2 m, as simpler sheet pile walls are more cost-effective. Some engineering details of floodwalls are shown in Figure 12.

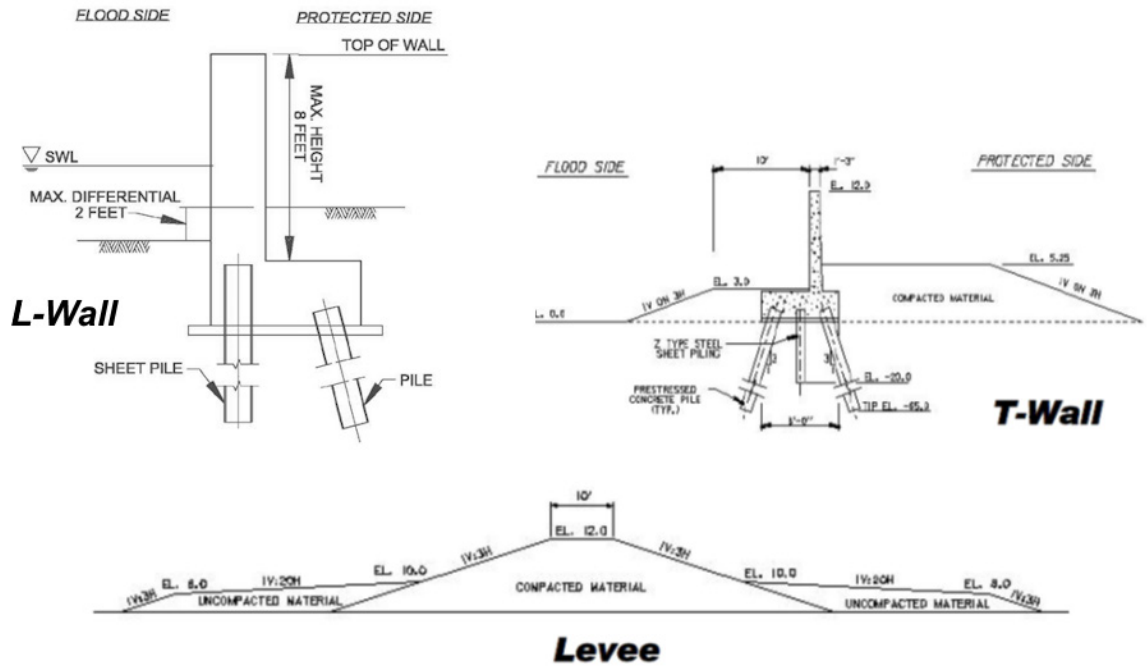

Figure 10: A sketch of hurricane protection structures used around New Orleans, comparing a classic earthwork levee cross section to a levee with T-wall (USACE, 2006) and an L-wall (USACE, 2012).

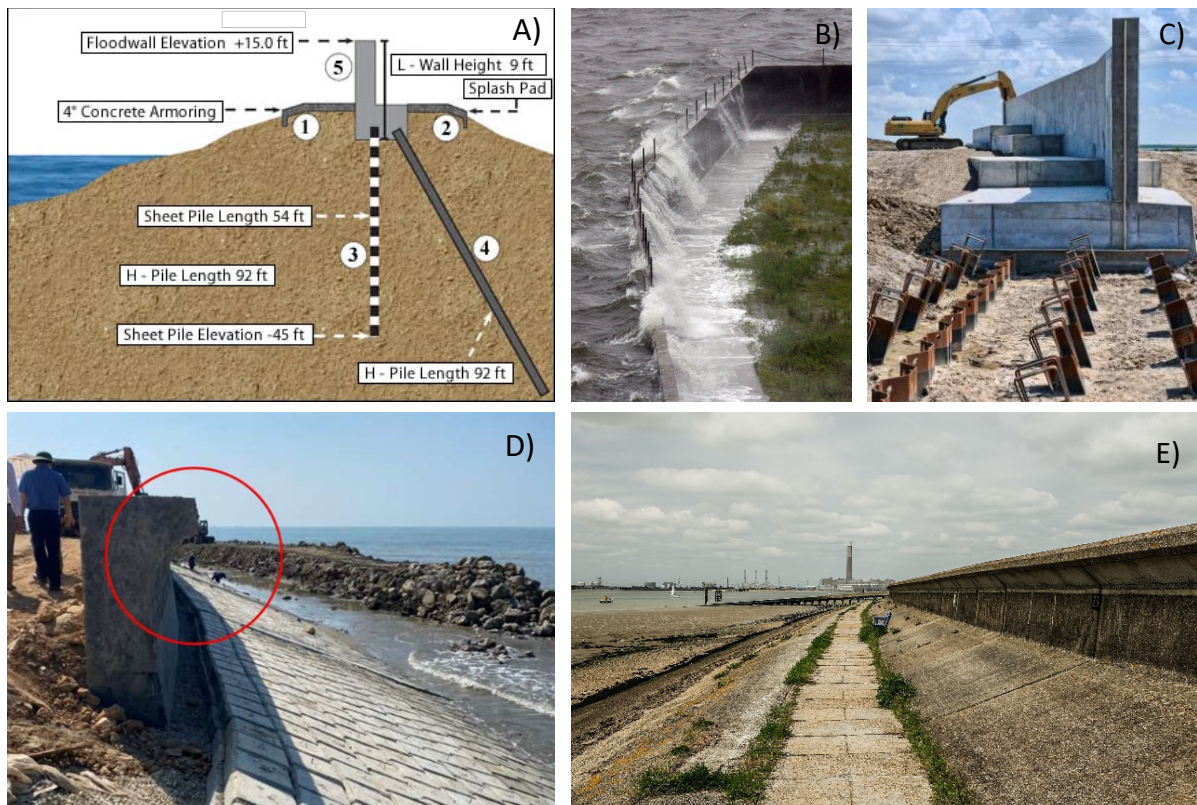

Figure 11: A) A sketch of an L-wall with an H-pile for enhanced stability and a splash pad against erosion. B) a flood wall with the erosion-resistant splash pad in action (USACE, 2019). C) A concrete floodwall during construction in New Orleans, with a foundation of steel sheetpile and H piles (Jonkman et al., 2021). D) A curved or straight nose (parapet) can be used at the top of a floodwall to reflect waves back and reduce overtopping, like here at the Hoang Hoa sea embankment under construction in Vietnam (within red circle) or E) at this seawall in the UK (by [Scott Wylie](#), CC BY licence).

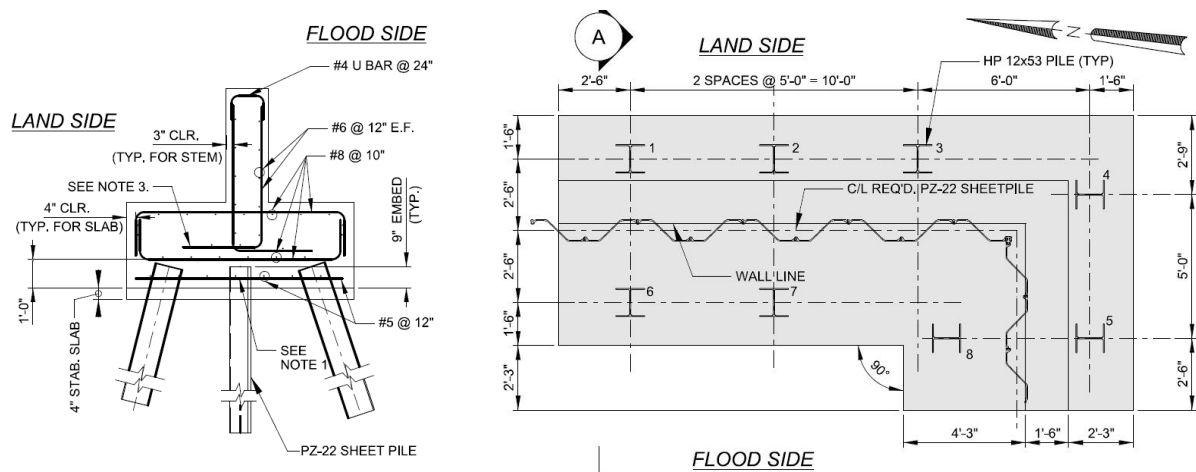

Figure 12 Some details of elements in the Carrollton floodwall project in New Orleans, USA. Left: cross section of a T-wall monolith with H-piles, sheet pile and rebar. Right: plan view of a corner in a T-wall, with sheet pile and H piles indicated. Courtesy of USACE (2020)

In terms of direct construction costs, floodwalls are more expensive than traditional earthen embankments due to the extra elements and materials needed. In New Orleans for instance, the costs of earthen embankment raising after hurricane Katrina were approximately €2-5 million/km per m raising, compared to €4-12 million/km per m of floodwall raising or construction (Jonkman et al., 2013). Annual operation and maintenance expenses vary widely, from 0.01% to 1% of the initial investment, with access gates a factor contributing to higher O&M costs (Aerts, 2018). Experience from Vietnam shows that the materials and construction costs of floodwalls are usually two to three times higher than for traditional embankment heightening and widening. However, by saving space, project expenditures on necessary land acquisition or compensation of land and building owners are reduced. This is especially beneficial at urbanized locations where land prices are high.

Subterranean wall at the embankment crest

During a prolonged high-water event, water can infiltrate an embankment body and increase the pore pressures. This decreases the effective shear and stress resistance of the soil, potentially resulting in failure of the inner slope (Figure 13A). And when the water level suddenly drops at the end of a high-water event, excess pore pressure can also result in failure of the outer slope (Figure 9). These problems can be mitigated using underground concrete walls or sheet pile structures, that A) stabilize the soil, resisting slope failure, B) reduce water infiltration into the embankment body, preventing pore pressures that would otherwise lead to slope failure and/or C) take over the water-retaining function when a slope has failed (TAW, 2004). Similar to the subterranean wall at the inner slope, the extra slope stability offered can also be used to create a steeper slope or partially vertical slope at an existing embankment, i.e. to heighten the embankment without widening it.

When the concrete wall or sheet piles are placed near the outer edge of the crest as an independently water-retaining structure (Fig. 12B), they can ensure that failure of the inner or outer slope does not result in dike breaching by taking over the water-retaining function. In addition, an impermeable wall at this location can positively affect slope stability by reducing water infiltration into the embankment body. When placed at the landward side of the crest, through the expected slip circle, these structures can prevent slope failure by counteracting slip

movement (Fig. 12C, D). This resisting effect on slip failure, makes the placement at the inside edge of the crest usually more effective than at the outside edge. Lastly, for an even more stable structure, two parallel walls can be installed and connected to each other, forming a coffer dam (Fig. 12E, F).

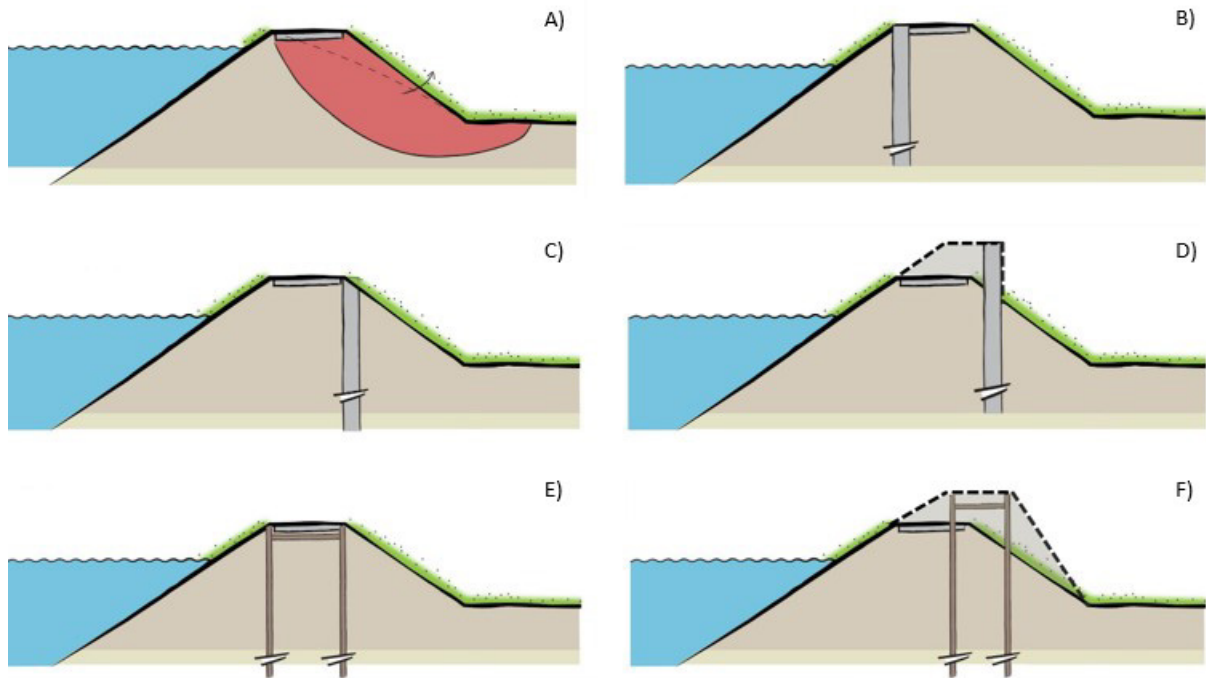

Figure 13: Instability to the outer slope (A) poses a major treat to embankment safety. This can be counteracted by placing an underground wall or sheet piles at the outside of the crest, such that slipe failure at the inner slope does not lead to embankment failure (B). Alternatively, to prevent slip failure, they can be placed at the landward side of the crest (C, D) or at both sides of the crest (E, F), possibly connected to form a more stable construction. Apart from preventing inner slope failure where it is a risk, solutions can also be used to steepen the inner slope and increase embankment height (D, F). NB: not to scale, slopes are drawn too steep. Adapted from RHDHV (2016)

The techniques and construction methods are essentially the same as for subterranean walls at the outer slope. Accordingly, these structures can be made as reinforced concrete wall or as steel sheet pile. Concrete walls are usually cast in place with steel reinforcement, also called diaphragm wall or slurry wall (Figure 14). Sheet pile walls can be driven in using hammering, hydraulic pressing or vibrations. Alternatively, structures at the inner crest that serve to prevent macro instability (i.e. connect the potential slip circle to deeper soil) and do not need to form a barrier against water, can be made from reinforced concrete piles placed a small distance apart ($\pm 10\text{cm}$). Independent of construction material, there are broadly two approaches to resisting lateral forces. First, construction can resist horizontal forces is by their own resistance to shear and bending. In this case they often extend into a stable subsurface layer (if present). Although this requires a deeper construction, extending into a settlement-free soil layer can negate the problem of embankment consolidation and the need to add a settlement margin to the wall height. Secondly, lateral forces can be resisted using soil anchors (see also Figure 17). When two parallel walls are placed under the crest, they can be connected using tension rods to anchor each other (Figure 15). From Dutch experience, construction costs for sheet pile are approximately $\text{€}150/\text{m}^2$ to $\text{€}250/\text{m}^2$, with unit costs increasing with sheet pile depth (Broers, 2015).



Figure 14: Installation of a concrete diaphragm wall near the outer edge of the embankment crest with a grab trenching machine, near Schoonhovenseveer, Netherlands.

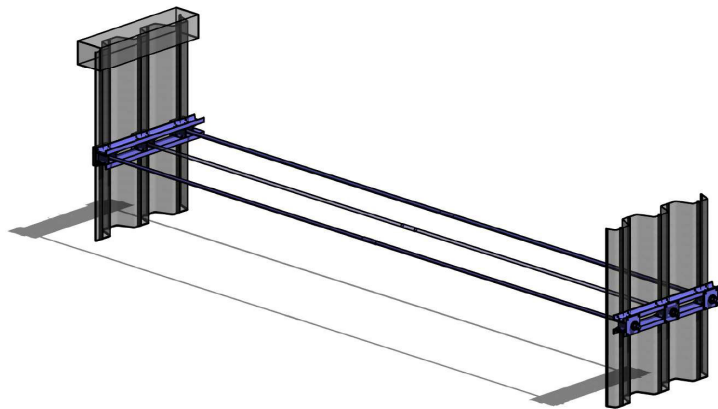

Figure 15: Detail of two parallel sheet piles as they would be placed inside the embankment body, connected by bars to anchor each other (Leene & Broekhuis, 2019, CC BY NC licence)

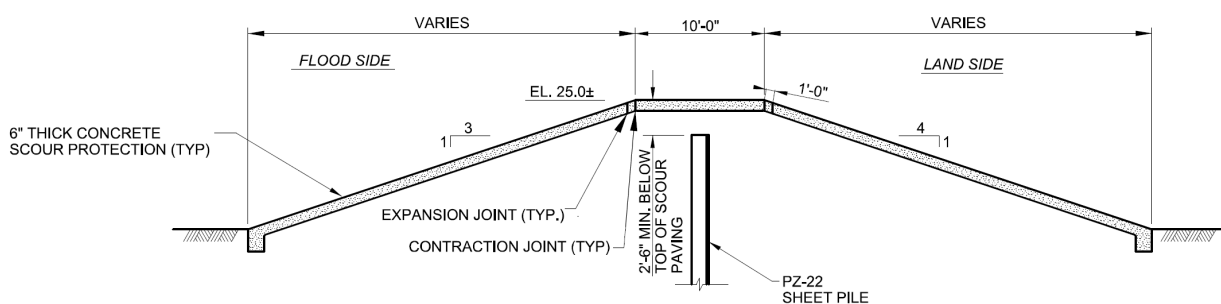

Figure 16: Cross section of a sheet pile wall, as used in the Carrollton floodwall project in New Orleans, USA. Distances in feet and inch (single and double apostrophe), EL. = elevation. Courtesy of USACE (2020)

3.4. Embankment upgrade techniques at the inner slope

Subterranean wall at inner slope or toe

Underground walls or constructions can also be placed at inner the toe of the embankment to improve macro-stability, just like subterranean walls at the embankment crest or outer toe. The construction options and considerations are similar, so a concrete wall or steel sheet piles

can be used, with optional ground anchors when the structure needs extra stability. This can for instance be achieved by driving a metal anchoring tube through the embankment body and sheet pile, connecting it to the sheet piles and pumping grout through the tube to form an anchor in the soil (Figure 17). Such *installation at the inner toe is usually more effective than installation at the crest*: a structure at this location can resist a larger part of the slip circle (see Figure 13A). Slope stability improves when the structure is made permeable to allow for groundwater flow, e.g. by having gaps between sheet piles (Figure 18): this keeps the phreatic line down, improving the shear resistance of the soil.

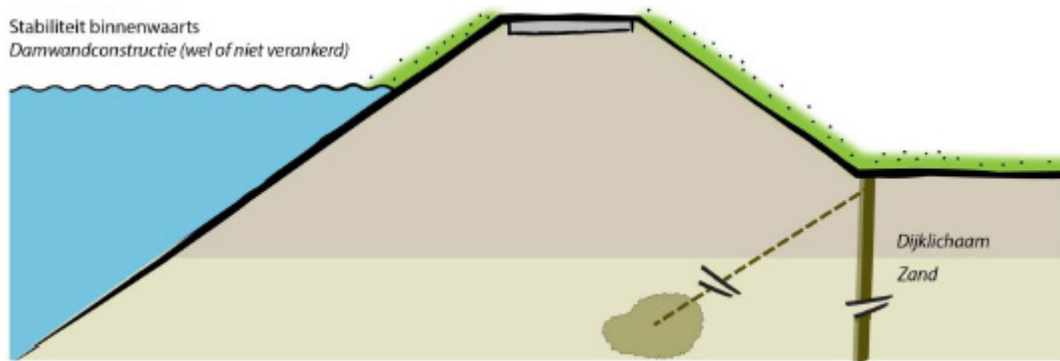

Figure 17: An underground wall at the inner toe from concrete or sheet piles can prevent slip circles from occurring, stabilizing the inner slope. To keep this construction in place, ground anchoring can be used. Adapted from RHDHV (2016)



Figure 18: Installation of sheet pile walls at the inner toe of an embankment near Ammerstol, the Netherlands.

Overtopping-resistant embankments

Raising embankments the classical way serves to decrease the *probability* of an extreme event leading to (too much) overtopping and embankment failure. Overtopping-resistant embankments are instead based on the premise of minimising the *consequence* of overtopping, by having an embankment and polder system that can withstand a limited amount of overtopping, decreasing the required crest height. This requires an embankment with sufficient erosion protection, and an embankment system that can handle the overtopping discharge, so with sufficient polder size or pump capacity that the flooding height from overtopping remains manageable.

When overtopping occurs, the shear stress from water flowing down can lead to erosion of the inner dike slope and eventually embankment failure (Van der Meer et al., 2010). To make embankments more erosion-resistant and allow for a lower crest height, either the shear stress needs to be reduced, or the shear strength of the dike cover increased. Shear stress can be reduced by making water flow down more slowly, so by choosing a more gentle embankment slope. However, this is not viable if available space is limited. Instead, the shear resistance of the embankment can be improved, by e.g. ensuring a dense high quality grass cover, or applying a stone or concrete dike cover (revetment).

For such erosion-resistant embankments, special care should be paid to transitions in embankment geometry or cover (Van Bergeijk et al., 2019; Van der Meer et al., 2010). The embankment toe for instance, so a geometry transition from sloping to horizontal, causes high local shear stresses, making it especially vulnerable to erosion. Likewise, the edge between roads and grass cover can create local turbulence in the flow, leading to erosion.

Apart from this protection against erosion at the inner slope from overtopping, care should be taken that wave overtopping does not cause a slip circle and sliding of the inner slope. In the Netherlands, steep inner slopes (typically 1:1.5 to 1:2) in the past frequently failed this way. Therefore, such embankments have been changed to milder 1:3 inner slope, where slip failures due to overtopping are unlikely (Van der Meer et al., 2010). So if an overtopping-resistant cover were to be applied at a steeply sloped embankment, additional measures might be needed to improve geotechnical macro-stability, e.g. subterranean walls or sheet pile.

Allowing a higher overtopping discharge has most effect on the required crest height when wave runup is high, e.g. at coastal locations with high waves. For example, calculations show that for a hypothetical 1:3 outer slope, allowing an overtopping discharge of 10 L/m/s instead of 1 L/m/s reduces the required crest height by *1.6-2 m* for waves with significant wave height of 2 m. When the wave height is 1 m, this advantage reduces to *0.8-1 m* (Zwanenburg et al., 2018). Here, the discharge of 1 L/m/s is usual for Dutch embankments, while 10 L/m/s could be considered when special measures are taken. This would require A) an embankment able to withstand the hydrodynamic conditions, in terms of erosion resistance and other failure mechanisms, B) the hinterlying system being able to cope with the increased water inflow, and C) no unacceptable consequences on other embankment functions, e.g. regarding access for general road usage or embankment inspection.

Stabilization of the inner slope

Elements installed into the embankment body at the inner slope can decrease macro instability, similar to the underground walls at the crest or inner toe described before. These techniques are based on having elements through the expected slip circle into more stable ground, that A) pre-stress the soil, increasing shear resistance, and/or B) directly withstand (a portion of) the shear force that causes slip failure.

Soil nails form an example of this technique. These nails consists of metal rods driven into the ground using drilling, pressing, percussing hammering, vibration hammering, or other techniques. These nails can be placed directly into the soil for moderate slopes, or for steep slopes as part of a soil nail wall, where nails surrounded by grout anchoring anchor a shotcrete wall or other wall facing. Figure 19 shows an example of soil nails with plate heads for extra shear resistance against shallow soil flow, driven directly into a riverbank. In this case, the soil nails

rely on natural roots rather than shotcrete to prevent soil movement between nails. Figure 20 shows a typical installation process for drilled soil nails anchoring a wall, as used for e.g. tunnel installations.



Figure 19: Left: Soil nails of 35 mm with a plate for extra resistance against shallow soil flow. These were used to stabilize a 30 m high riverbank along the Kaministiquia river in Canada, with nails in a grid of 1 m to 1.5 m. Right: nails were installed using percussing hammering (Fabius et al., 2008).

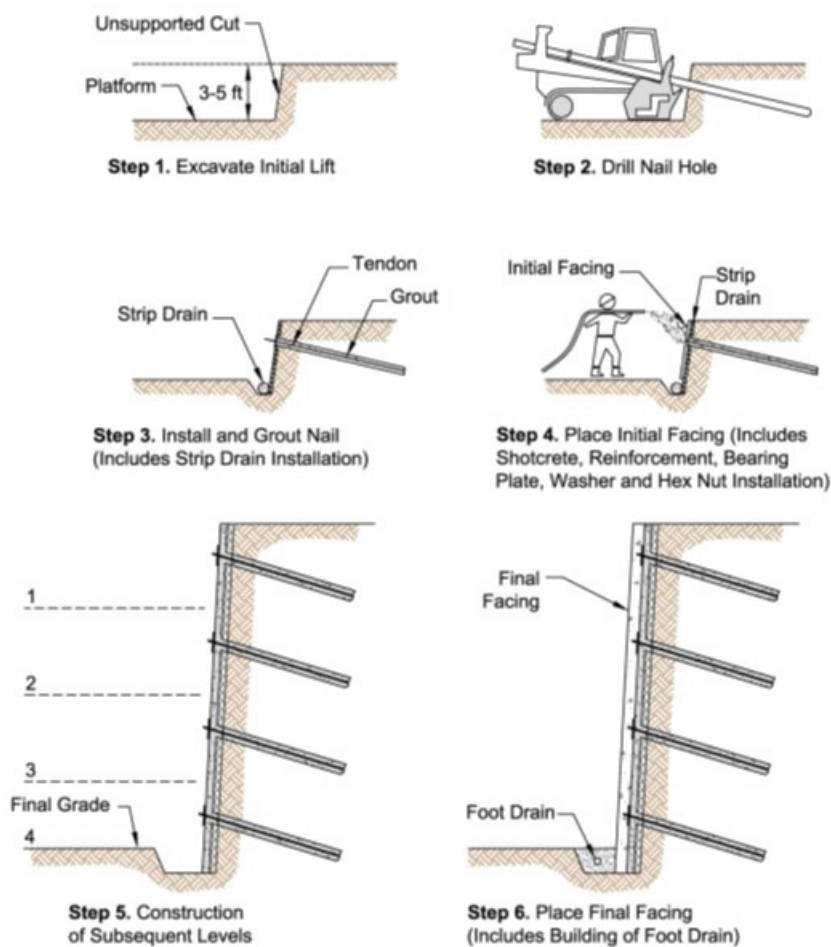

Figure 20: A typical construction sequence for soil nail walls, where holes are drilled, filled with a grout nail and anchored to the wall before deeper levels are excavated (Lazarte et al., 2015).

In case of expected deep slip circles, longer dike dowels can be used: heavy metal rods surrounded by grout that function as shear key and extend through the slip circle into a stable subsoil layer (Figure 21). They are installed by drilling a large hole, filling it with grout and then installing the metal rod in the grout. The advantage compared to concrete or sheet pile walls is that less heavy equipment and materials are needed, without vibrations or large soil works.

However, the disadvantage of these soil stabilization techniques is that long-term experience is relatively limited. While e.g. nail walls have long been applied to improve slope stability in mountainous areas, their application for embankment reinforcements is more recent and limited. So while their efficacy is clear, the uncertainty in their robustness and applicability limits is larger. Consequently, application of these techniques requires more engineering judgement and detailed calculations in lieu of well-established guidelines.

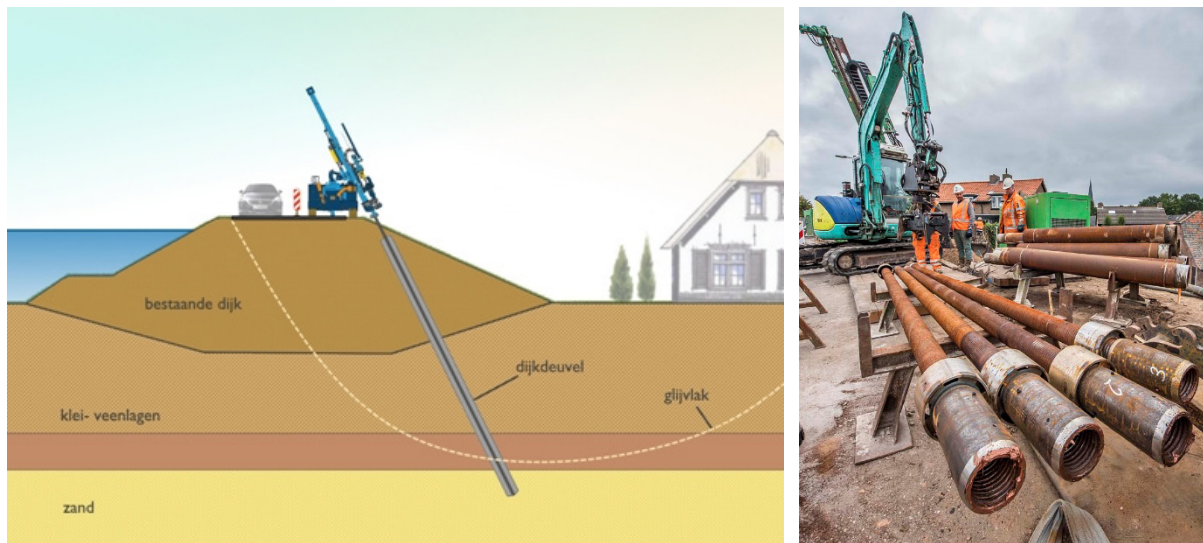

Figure 21: Left: dike dowels are metal rods surrounded by shear that resist shear the slip circle to stable subsurface layers. Right: The metal rods and equipment used to install dike dowels (source: dijkdeugel.nl)

3.5. Techniques summary and selection

Several techniques were presented for embankment upgrading when available space is limited (Table 4). Three techniques improve safety by decreasing wave runup and hence wave overtopping: breakwaters, elevated foreshores and high-roughness revetments. Next, three techniques improve safety by raising the crest, either directly (floodwalls), or indirectly by allowing for the stable construction of steeper slopes (subterranean walls or slope stabilization). Lastly, the embankment and polder system can be designed to withstand higher overtopping discharge over the embankment, reducing the necessary crest height.

Table 4: Comparison of the advantages and disadvantages of the proposed techniques.

	Breakwater	Elevated foreshore	High-roughness revetment	Floodwall	Subterranean wall	Stabilization inner slope	Overtopping-resistant embankment
Principle	Dampen waves	Dampen waves	Dampen waves	Raise crest	Steepen slopes => raise crest	Steepen slopes => raise crest	Lower crest needed
Effectiveness	+	+	-	++	++	++	-
Costs	-	?	~	--	--	+	+
Spatial footprint	-	--	+	+	++	++	~
O&M	~	~	+	Wall: + Gates: -	+	-	+
Upgradability	+	+	~	--	-	+	~
Risks and limitations		Soft solution: dynamic		Difficult combination with road/access		Risk: new technology	

Detached breakwaters, like the other wave-dampening techniques, are only effective at locations with substantial waves. For this wave dampening, they are very effective. The main advantage of breakwaters is that they offer the option to shift the spatial footprint, i.e. to take measures at a different location, when construction work at the embankment itself would be complicated. However, by dedicating a new area to flood protection, their spatial footprint is quite high. As a large hard structure, they are relatively expensive, with costs estimated at \$1.4-6 million/km (Aerts, 2018, USA price level). A disadvantage for Bangladesh is that they usually rely on large stones, so not a locally abundant building material. Annual operation and management (O&M) expenses are quite in line with other structures, at 0.01% to 1% of the initial investment. Of course, the exposed nature of breakwaters means they can be damaged by waves due to improper design or extreme conditions, or by scour in meandering rivers. As breakwaters leave the embankment free, that can still easily be upgraded later when needed.

Elevated foreshores also improve safety through wave dampening. Their advantage, like breakwaters, is that they offer the option of taking measures in front of the embankment. However, they need much more space. A typical example is a mangrove system, natural or restored. Alternatively, elevated foreland can be created by relocating embankments (managed realignment). While this may be cost-efficient if it avoids the need for expensive revetments or hard structures, the land given up makes it unfitting as a limited-footprint technique and socially difficult to implement. In either case, costs can vary wildly, depending on the chosen implementation and the required land acquisition.

High-roughness revetments are another option to dampen waves. The potential wave dampening is lower than the previous techniques, but so are costs and material needs. Land use is quite efficient, and very efficient when a revetment already planned/present is replaced by one with a higher roughness. Maintenance is relatively straightforward: revetments are physically reachable from the embankment, and existing applications in Bangladesh mean there is

local experience available. Annual maintenance can be quite expensive relative to the initial investment (e.g. 2-4% for UK projects with rock armour, Aerts, 2018), but this is also due to lower absolute investment costs than floodwalls or breakwaters. Future upgradability of embankments remains quite good: revetments do not limit future upgrade options for the crest or landward slope, while revetments themselves are still relatively easy to adjust or remove compared to underground hard structures such as sheet piles.

Floodwalls directly add crest height, making them very effective against overtopping and overflow as failure mechanisms. However, they are quite costly: e.g. typically \$5-12 million/km/m height in the USA (Jonkman et al., 2013); about 2 to 3 times the price of earthen embankments. Direct space usage is very limited, but floodwalls are difficult to combine with the road and traffic commonly present at the crest in Bangladesh. Even if a floodwall can be placed at the side of the road, this still severely limits embankment crossing for houses at the other side of the floodwall, fisherman cattle, etc. Exit gates can solve this, but many would be needed, driving up costs greatly and introducing operation and management risks. As moving parts, gates need much more maintenance than fixed structures, and introduce a risk of not closing, especially in heavily used inhabited areas where they might become damaged or blocked. Hence, suitability is limited to locations where side access is not important, e.g. if embankment widening toward a river must be avoided to not restrict the river, rather than for active land usage neighbouring the embankment. A floodwall advantage is that less soil is needed for raising the embankment; useful when the availability of suitable soil is limited or if the additional weight of raising embankments with soil would lead to excessive settlement or soil instability (e.g. when directly neighbouring a steep channel slope or quay). Future upgradability is poor: raising an existing floodwall is difficult and existing floodwall foundations often cannot handle the increased forces associated with higher floodwalls.

Alternatively, slopes can be steepened to raise embankments without widening them. Here underground walls, typically consisting of sheet piles, can be used to maintain slope stability. Usually, the most efficient location to place these walls is near the inner dike toe. Here they resist the largest part of the slip circle, and allow for steepening the inner slope rather than the more critical outer slope. Costs are quite similar to floodwalls: Dutch examples show costs increase again by a factor 2 to 3 compared to classic earthen embankments (section 4.3). The spatial footprint is very good, with a narrow construction hidden underground. As a fixed construction, not exposed to waves or elements, the required maintenance is limited. The underground construction is difficult to update in the future, but the earthen embankment body remains more easy to upgrade than with floodwalls.

The same approach of slope stabilization and steepening can also be applied with soil nails or dike dowels. This decreases the materials and equipment needed, reducing costs. And upgradability benefits from the option of adding more soil nails or dike dowels at a later stage. However, these techniques are quite novel, with most existing applications still in a pilot phase. This means more stringent monitoring and inspection is essential to keep an eye on embankment performance. Even then, such an innovative, less proven technique introduces risks of unexpected behaviour or failure.

Lastly, embankments could be made more resistant to overtopping, lowering the required crest height. Hereto the embankment, and especially inner slope, need to become more erosion-resistant. Assuming some revetment here, scores are similar to the high-roughness revetment,

adjusted for the revetment being simpler (less wave impact), but present where they were previously not (more land usage). However, this approach also impacts other embankment usage, making driving or walking over an embankment during design conditions more difficult and dangerous. Hence, it combines poorly with the busy space-constrained situations studied here. Apart from the direct surroundings, the larger polder system also need to be able to cope with the increased water influx from overtopping.

To choose a technique, or design a specific implementation, there are some specific considerations relevant to the Bangladesh context. The de facto chaotic land use around embankments can pose a challenge to regular operation. So robust solutions are needed. Also, maintenance can be irregular in Bangladesh, as shown by past experience at polder sluices, where maintenance not covered by the World Bank loan but relying on regular government budget could be erratic. Second, any technique and design needs to take into account how heavy construction material and equipment can be transported to location. Roads on embankments can be narrow and unpaved, so part of this transport might need to occur over water.

Overall, the best performing technologies in terms of effectiveness, applicability in space-constrained situations and proven performance are the floodwall and crest heightening through a steep inner slope with underground sheet pile wall for stability. The underground sheet piles are most appropriate where access from the (road at the) embankment crest to both sides is important. If this is not essential, floodwalls can also be used, with the advantage that buildings on the inner slope could potentially remain. Both techniques will be illustrated in the next sections using international example projects.

4. International example project 1: embankment reinforcement at Gorinchem-Waardenburg, The Netherlands

4.1. Description of the project

About 60% of the Netherlands is flood prone as it is below sea level. This flood hazard is caused by floods on the major rivers, Rhine and Meuse or storm on the North Sea. The river Waal is the southern and main branch of the river Rhine in the central part of the Netherlands. Project Gorinchem-Waardenburg involves the reinforcement of 23 km of embankments along the northern bank of the river Waal (Figure 22). This dike section needs reinforcement by increasing its height and improvements for macro stability and piping. At the project location, under normal conditions the river Waal is about 300 to 400 m wide. During floods, the water level will rise by about 6 to 8 m, increasing the width of the river between 1200 to 1500 m. There are many stakeholders along the embankment and the foreseen works to enhance the existing embankment to meet safety requirements affects house owners, property owners, businesses, natural environment, monuments, and other infrastructure.

The project is carried out by an alliance formed by the client, Waterboard Rivierenland, in partnership with the contractors Heijmans, GMB and De Vries & Van de Wiel (DEME); and Royal HaskoningDHV. The project objective is to ensure flood protection by improving the river embankments for the next 50 years considering climate change. However, the water-engineering infrastructural works are designed for a lifespan of 100 years. The project also

incorporates the existing and future functions of the embankment such as enhancing the living environment, recreation, nature, and transport.

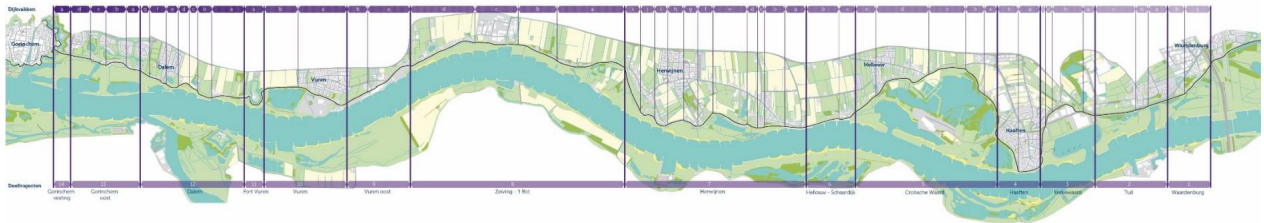

Figure 22: The project location of Gorinchem-Waardenburg on the north bank of the Waal

4.2. Current situation

The dike section between the towns Gorinchem and Waardenburg does not meet the current safety standards of the probability of flooding 1/10.000 per year. The main issues with the embankment concern the crest height, macro stability of the outer and inner slope and piping. Therefore, the project involves the reinforcement of 23 km of embankment, protecting a hinterland with 100,000 inhabitants from flooding. Along the embankment there are eight villages and many individual houses. This means that there is little space for reinforcement in soil on the landside of the embankment. The project ambition is to carry out the reinforcement without a negative impact on the current stakeholders.

The 1/10.000 per year situation used to determine the crest height is based on a high discharge on the river in combination with mild winds, so the local waves are small. For designing the erosion protection on the outer slope conditions with a lower discharge and storm conditions have been used.

The new crest height of the embankment is designed on an overtopping discharge of 10 l/s/m¹. Higher discharges on the river Waal due to climate change for the coming 50 years have been considered. The necessary crest height in 2075 varies from 10,0 m +NAP¹ upstream at Waardenburg to 6,7 m +NAP downstream at Gorinchem. Also considering settlement during the 50 years, the current crest height is increased between 0.25 and 0.75 m.



¹ NAP is the Dutch ordinance level, approximately the same as Mean Sea Level.

Figure 23: A typical situation with a house on the inner slope of the embankment



Figure 24: The embankment with monumental buildings on its inner slope



Figure 25: Fort Vuren at the Waal, part of the World Heritage Site Dutch Water Defence Lines

4.3. Design and cost indications

4.3.1. General design choices

The total project was divided into subsections. The subsections were based on uniformity within the subsection based on geotechnical conditions, current land use and other criteria that influence the design. For each subsection the best alternative was chosen and that was combined into an integral design for the 23 km of embankments.

Within the project three alternatives were defined per subsection:

- 1) **Reinforcement landwards with soil:** in this alternative the embankment is reinforced on the landside of the embankment with soil. This alternative does not decrease the width of the river and using soil is more sustainable.
- 2) **Reinforcement towards the river with soil:** in this alternative the embankment is reinforced towards the riverside. This alternative narrows the river and leads to higher water levels upstream of the river. Using soil is more sustainable.
- 3) **Reinforcement with construction:** in this alternative the embankment is reinforced with a construction. This alternative needs the least space and does not affect land use on the land- and riverside. Using constructions is less sustainable.

There is a preference in the project to reinforce the embankment with soil because of flexibility for reinforcements in the far future and sustainability. For reinforcements towards the river compensation is necessary if reinforcement leads to higher water levels upstream of the river. The combination of nature development, the winning of soil and compensation for outwards reinforcement within the project made this alternative possible within the project.

It should be noted that even for the alternatives Landwards reinforcement with soil and Towards the river with soil a construction is often necessary for piping because the impact of alternatives completely using soil is too large on land use and costs.

The evaluation of the three alternatives for the subsections resulted in the following design:

- 6 km Landwards with soil
- 10 km Towards the river with soil
- 7 km Construction

In the following paragraph an example of the ‘Construction alternative’ is given. Examples of ‘Landwards with soil’ and ‘Towards the river with soil’ are included in Appendix A. For each example the quantities and costs are given per linear meter of dike.

Reinforcement with construction (cross section TG405)

At cross section TG405 the embankment is reinforced with a sheet pile construction (type AZ24-700) of 18 m deep against macro instability of the inner slope and piping/heave. A grout injection anchor is attached to the sheet pile. The new crest height is increased by ca 0.4 m. The current shape of the embankment remains mostly the same. The erosion layer on the outer slope is reshaped. A new road is made on the foundation of the current road.

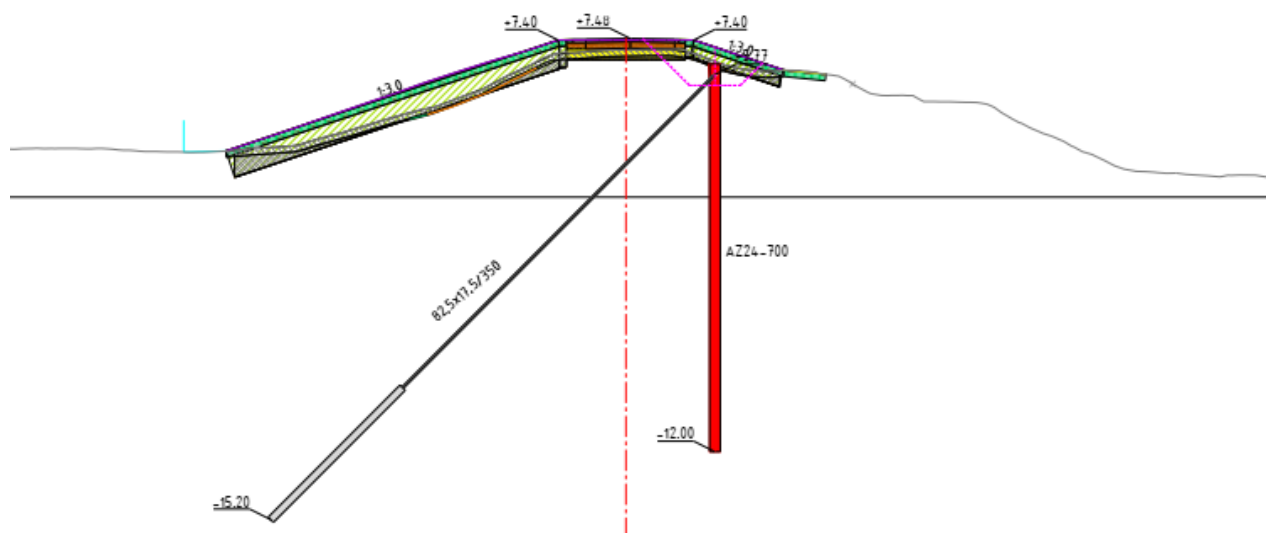

Figure 26: Reinforcement of the alternative Construction (cross section TG405)

The *direct construction costs* of the reinforcement at this cross section amounts to €3.739/m (Table 5), compared to €2.072/m for the landward reinforcement with soil and €1.215/m for reinforcement toward the river with soil (Appendix A, Table 6 and 7). So compared to the traditional reinforcements, the direct construction cost of the sheet pile construction was 80% to 200% higher. This is in line with the 200% difference found by Broers (2015) for a design study of a Dutch river embankment.

Table 5: Quantities and direct building costs per linear meter of dike for the alternative Construction (cross section TG405)

Structure	Quantities	Total costs
New dike core (m ³ clay)	0	€ -
Reusable material (m ³ clay)	0	€ -
Stability berm (m ³ sand/soil)	0	€ -
Erosion layer (m ³ clay)	10	€ 230
Top layer (m ³ soil)	5	€ 40
Sheet pile steel (tonnage)	2,53 (18.5 m AZ24-700)	€ 1.897
Sheet pile installation (m ²)	18,5	€ 462
Anchor grout injection (m width)	1	€ 1.000
Road (m ²)	3.5	€ 140
Road foundation (m ²)	0 (reuse of current foundation)	€ -
Land acquisition (m ²)*	0	
Total		€ 3.769

* Land acquisition is not part of de direct building costs but is part of het total project costs

4.3.2. Total project costs

To estimate the *total construction costs*, a surcharge can be used for indirect construction costs, on top of the aforementioned direct construction costs (tables 4, 5 and 6). For the total Gorinchem-Waardenburg project, this surcharge is 44%, covering:

- Non-recurring costs (supply and disposal, mobilization/demobilization, temporary construction roads, etc.).
- General construction site costs (rental of office space, rental of driving plates, workplace security, accessibility facilities for residents, depot management, etc.).
- Time-related construction costs (project management and construction supervision, quality checks, etc.).
- Overhead and a surcharge for risk and contractor profit.

The *total costs* of the realization phase of the project are 360 million Euro including VAT, or €15 million/km (price level 2020), 62% of which consists of construction costs. The remainder includes:

- Nature development in the flood plains at four locations.
- Land acquisition for the embankment reinforcement.
- Supervision, detail engineering and site engineering.

Expenditures prior to the realization phase for the design and planning were approximately an additional 47 million Euro including VAT.

4.4. Additional option: allowing for multiple functions

Reducing the available space for embankment reinforcement within the project Gorinchem Waardenburg is mostly done with sheet pile walls to reinforce the embankment for macro-stability of the inner slope and piping. By shifting the embankment towards the river, it is possible to avoid needing space on the landside of the embankment.

The project has also put effort in allowing the reuse of the berms on the land side for agricultural purposes. To allow for agricultural use it is necessary to protect the minimum dimensions of the berm. Which means that the thickness of the top-layer is increased to allow for the intended future land use. This option has been locally applied in agreement with the landowner. It is therefore not a standard option, but allowing for multiple functions on the embankment can lead to a smaller impact on the stakeholders.

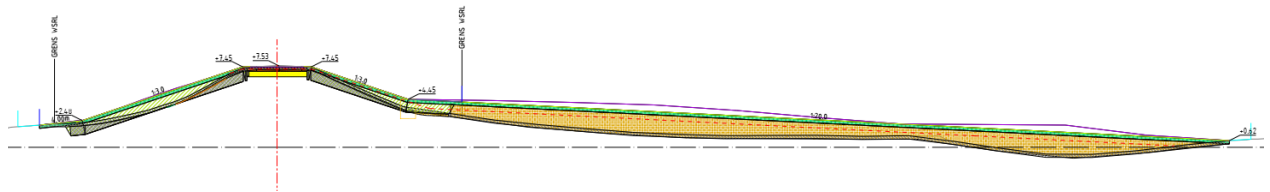

Figure 27: Embankment with a long soil berm for macro-stability and piping with an extra thick top layer to allow for agricultural use.

In other locations the design allows for houses on the embankment. These houses are build outside of the necessary profile of the embankment for flood defences purposes. Additional sand is added at the embankment to allow for the houses. In Figure 28 and Figure 29 an example is given.



Figure 28: Location of a house at the inner slope of the embankment

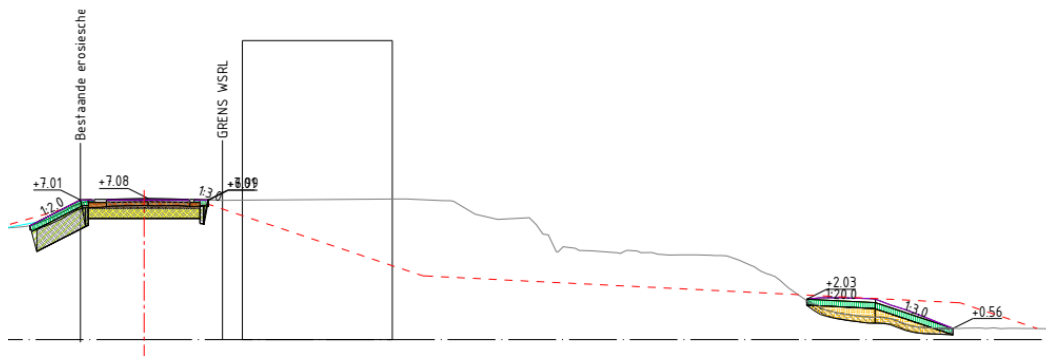

Figure 29: Cross section of the embankment at the house on top of the additional sand

4.5. Lessons for Bangladesh

Embankments in the Gorinchem-Waardenburg project are reinforced to decrease their vulnerability to overtopping, slope instability and piping. The water level at the river during design conditions is approximately 6 to 8 meters above the average water level, with limited wave heights. In terms of hydraulic conditions in Bangladesh, this is comparable to e.g. the Sangu river in Polder 63/1a, just south of Chittagong. Embankments here also face a combination of high surge levels and relatively limited waves (+5.3m surge level and 1.41m high waves with a 1/25 years return period, Van Berchum et al., 2020).

This project showed an example and cost overview of sheet piles being used at the landward slope to increase slope stability, allowing the embankment crest to be raised without widening (Figure 26). In addition, it illustrated how multifunctional embankment usage, where houses are built on the inner slope, can be taken into account during design by using an extra margin in the embankment profile, to prevent these houses from having a negative effect on embankment strength. And more in general, it outlined a design approach for space-constrained locations, where systematically both soil-based embankment reinforcement designs and construction-based designs are prepared, so that their costs and merits can be compared.

5. International example project 2: Floodwalls in New Orleans

5.1. Flood protection in New Orleans

New Orleans is a city of approximately 400,000 inhabitants, in the southeast of the United States where the Mississippi flows into the Gulf of Mexico (Figure 30). Its location makes New Orleans highly vulnerable to flooding, being intersected by the Mississippi river, surrounded by coastal wetland, bordering two lagoons in open connection to the sea (Lake Pontchartrain in the north and Lake Borgne in the east), while having approximately half of the metropolitan area below sea level. In 2005, Hurricane Katrina resulted in a catastrophic flooding in New Orleans, causing approximately 1400 fatalities and 125 billion in damages in New Orleans and its surroundings (Knabb et al., 2023). In response to this disaster, the US Army Corps of Engineers developed the ‘Hurricane and Storm Damage Risk Reduction System’ (HSDRRS), an infrastructure project of that aims to provide the greater New Orleans area a 100-year level of flood protection. This \$14.5 billion project consists of 210 km of levees, floodwalls, canal closures and pump stations (Figure 31).



Figure 30: The location of New Orleans in the state Louisiana and in the United States (Copyright [Freeworldmaps](http://www.freeworldmaps.net))



Figure 31: The HSDRRS flood protection system of New Orleans, with the West Return Floodwall indicated in green (adapted from Swenson, 2022)

5.2. The West Return Floodwall

The West Return Floodwall is part of the HSDRRS project, built in the west of New Orleans to protect the city against storm surges from Lake Pontchartrain. It is examined in this section as an example project of how floodwalls can be used to improve flood safety. The West Return Floodwall extends for 4.5 kilometres from Lake Pontchartrain to the Louis Armstrong New Orleans International Airport (Figure 31), with the I-10 highway overpass over the floodwall. It protects the neighbourhood on its east, with a canal and marsh in open connection to Lake Pontchartrain west of the wall. After hurricane Katrina, the existing levee and floodwall were deemed insufficient in elevation, stability and scour protection to provide protection against a 100-year flood. Because of the difficulty of safely raising an existing floodwall, a new floodwall was built just outside the old floodwall, approximately 0.5 m to 1 m higher than the old floodwall. After construction, the old wall was demolished to 2 inches below ground surface (USACE, 2008).

The new floodwall is built as a concrete T-wall with sheet piles and H-pile foundation (Figure 32, 33), on top of an existing levee and 10 m to the west (flood side) of the old floodwall. The design differentiates between the section north and south of the I-10 highway overpass, with an elevation of 5 m (16.5 ft) south of the I10 and 5.3m (17.5 ft) north of the I10. The wall is approximately 4 m high and has berms at both the flood sides and the protected side. To allow for inspection and maintenance, the concrete base slab on the flood side is constructed 3.8 m wide along the entire length of the wall, with four vehicle gates for access. Rock armouring is used to protect the flood side against scour and erosion, and additionally for critical areas of the protected side (utility pipeline crossings or transition points with other levees, floodwalls, or pumpstations). The project costed \$120 million, amounting to \$27 million per km. The construction required approximately 75,000 m³ of concrete, 60,000 m² of sheet piling, 450,000 m of H piles and 75,000 m³ of fill (USACE, 2008, 2009).

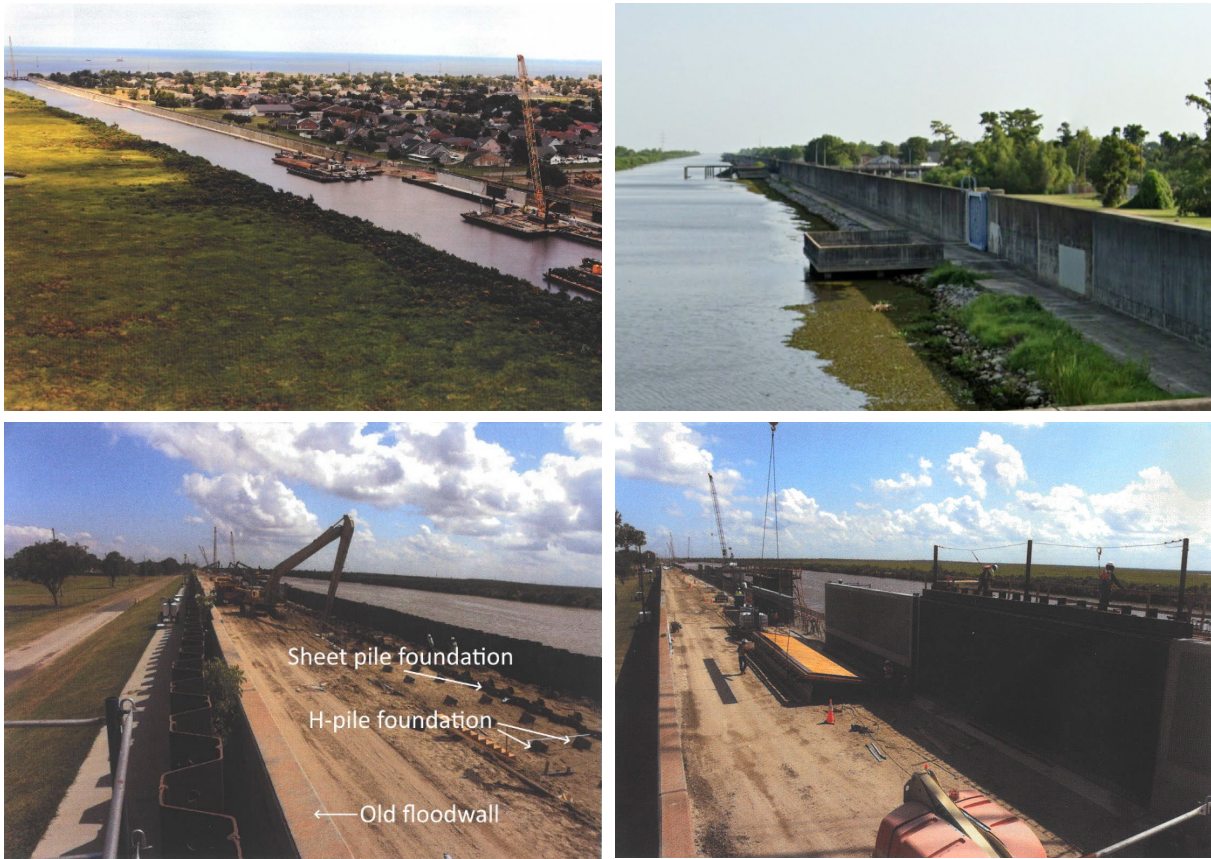

Figure 32: Photos of the West Return Floodwall. A) View over the wetlands and outfall canal to the West Return Floodwall under construction. The old floodwall is still visible through gaps in the new wall, Lake Pontchartrain is visible in the back. B) View from the I-10 overpass to the floodwall, showing the rock armoring, the concrete base/vehicle road, a gate (blue) with vehicle turning pad and the floodwall itself. C) The new floodwall under construction, sheet pile and H-pile foundation in place. D) The floodwall under construction, formwork for concrete being removed from wall. Sources: A, C and D: Evans-Graves Engineers (2012). B: Google Streetview.

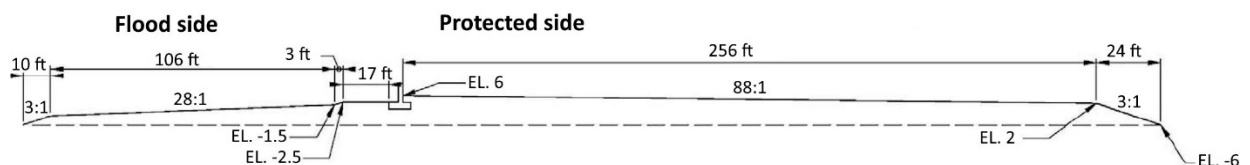

Figure 33: Typical cross section of the levee and floodwall. Distances in ft, EL. = elevation. Source: USACE (2009)

5.3. Alternative designs

Apart from constructed design, with a new seawall 10 m to the floodside of the old wall, a number of alternatives were considered (USACE, 2008):

- *New floodwall placed along the old wall alignment*
To place the new floodwall at the location of the old floodwall, the old one would first need to be demolished. This has the prime disadvantage that the neighbourhood would be vulnerable to flooding during construction. Additionally, construction would need to occur around underground pilings from the existing floodwall.
- *New floodwall landward of the old wall*
The presence of residential neighbourhoods directly landward of the old floodwall made a landward shift of the floodwall not feasible.
- *Modification of the old floodwall*

Design analysis of raising the old floodwall indicated that the old floodwall would not be structurally capable of withstanding the proposed loading conditions.

- *Earthen levee*
Building an earthen levee on the canal side of the old floodwalls was not viable due to insufficient soil stability in the surrounding areas.

5.4. Lessons for Bangladesh

The West Return Floodwall in New Orleans was reconstructed because the old levee and floodwall did not meet the required safety standard in terms of elevation, stability and scour protection. This project showed an example of a concrete T-wall being used increase the crest height, with photos detailing the building process. In addition, it showed the considerations involved for upgrading a floodwall instead of earthen levee. Hereby, it also demonstrated the importance of futureproof floodwall design: floodwalls are more difficult to raise than earthen levees, making it extra important their initial design match the safety level required during their life span.

6. Discussion and conclusions

Embankments in Bangladesh that need to be upgraded to a higher safety level generally need to be raised, i.e. the primary failure mechanism is overflow and overtopping rather than macro-instability or erosion. An overview was made of techniques used in such cases when space for embankment upgrades is limited. The first approach is to limit the embankment height needed, by dampening waves before they reach the embankment, dampen waves at the embankment or making embankments able to withstand a higher overtopping discharge. Secondly, measures can be taken to safely increase embankment height without adding extra width. Floodwalls can be used to directly add height on top of an embankment, while placing sheet piles or a concrete wall in the embankment body allows to make the embankment slopes steeper and the crest higher without causing slope instability.

Typically, if there is no space for embankment upgrading in Bangladesh at either the inside or outside of an embankment, this is because of buildings present at both sides of the embankment. In addition, a road is usually present at the crest. In this case, the ideal solution would A) keep both embankment toes at the same place, B) still have a road on top and C) not interrupt access from the road to the neighbouring buildings. So in order to increase the water-retaining height and increase safety, the slopes need to be made steeper. In this case, sheet piles or concrete walls in the embankment body can be used to maintain soil stability while increasing slope steepness and crest height. In cases where easy access from the (road at the) embankment crest to both sides is not essential, floodwalls can also be used. For exposed locations that face strong waves, rough revetments can alternatively be a good option to reduce the required embankment height, but the potential benefit is usually not as large as for (high) floodwalls or crest raising. All these techniques are widely used around the world, providing confidence in their effectiveness and ample experience to draw on for design and calculation methods.

The advantage of floodwalls compared to slope steepening with underground sheet piles is that floodwalls can be built quite tall, while the achievable advantage of slope steepening depends on the width and height of the existing slope. Also, buildings present *on* the inner slope do not necessarily have to be removed, like they have to for slope-steepening techniques.

Moreover, floodwalls decrease the soil needed for embankment raising, which is advantageous if (good) soil availability is limited or if the extra weight of an enlarged earthen embankment would lead to soil instability. On the other hand, underground sheet piles leave the crest free. Apart from allowing for easy access over an embankment, this also leaves more options open for future embankment raising, while floodwalls are notoriously difficult to raise once built. This is illustrated by the West Return Floodwall project in New Orleans (chapter 5), where a *new* floodwall was built because the old one was insufficient in elevation and stability. Theoretically, gates can allow for traffic through floodwalls. However, by adding moving elements, they greatly increase costs, maintenance requirements and operational risk, especially in Bangladesh where this traffic access would be needed at the majority of space-constrained locations. A construction risk shared by both techniques is insufficient stability. Care should be taken to design a robust foundation and cover to ensure they remain stable after overtopping. Storms exceeding design conditions may result in overtopping, but should not result in catastrophic failure and full embankment breaching. Lastly, the disadvantage of both techniques is that they are quite expensive. In the USA and Europe, these hard structures typically increase construction costs by a factor 2 to 3 compared to classical earthen embankments, e.g. leading to USA floodwall prices of \$5-12 million/km/m height (Jonkman et al., 2013), with annual operation and maintenance costing 0.01% to 1% of the initial investment (Aerts, 2018). In Bangladesh, where the costs of hard material are a more important factor in the overall construction costs, this relative difference is likely even larger. On the other hand, at space-constrained locations with many buildings around embankments, the reduction in the required space translates to cost savings through reduced expenditures on land acquisition and building (de)construction, as well as reduced project delays.

To study this further for Bangladesh, it is recommended to study a actual local case study with dense construction present around the embankment. By making concrete designs and cost projections for both traditional earthen embankment raising and the proposed hard constructions, using local cost levels, their feasibility and project costs can be compared. This is similar to the approach followed for the Dutch river embankment discussed in Chapter 4. For a fair comparison, it is important that such a comparison explicitly accounts for the savings from reduced land acquisition, building (de)construction and project delays.

7. References

- Adnan, M. S. G., Haque, A., & Hall, J. W. (2019). Have coastal embankments reduced flooding in Bangladesh? *Science of The Total Environment*, 682, 405-416. doi: 10.1016/j.scitotenv.2019.05.048.
- Aerts, J. C. J. H. (2018). A Review of Cost Estimates for Flood Adaptation. *Water*, 10(11), 1646.
- Asaduzzaman; Wang, T. (2020). Importance of Making More Water Dams and Construction of Concretes River Embankment in Bangladesh to Protect Flood. *Journal of Environmental Science, Toxicology and Food Technology* 14(11A), 43-53. doi: 10.9790/2402-1411014353.
- Bosboom, J., & Stive, M. J. F. (2023). *Coastal Dynamics*. TU Delft Open. doi:10.5074/T.2021.001
- Broers, B. (2015). *Cost-effective levee design for cases along the Meuse river including uncertainties in hydraulic loads* University of Delft]. Delft.

- BWDB. (2022). *Consultancy Services for Feasibility Studies and Preparation of Detailed Design for the Following Phase of the Coastal Embankment Improvement Project (CEIP) - Polder Screening Report*.
- Dasgupta, S., Huq, M., Khan, Z. H., Ahmed, M. M. Z., Mukherjee, N., Khan, M. F., & Pandey, K. (2014). Cyclones in a changing climate: the case of Bangladesh. *Climate and Development*, 6(2), 96-110.
- Evans-Graves Engineers. (2012). *The fortress of New Orleans - A photographic tour of the largest civil works program in the U.S. History*.
- Fabius, M., Bo, M. W., & Villegas, B. (2008). Stabilization Of A 30 M High Riverbank In Canada With Nails, Plates And Roots. 6th International Conference on Case Histories in Geotechnical Engineering, Arlington,
- Hashim, A. M., & Catherine, S. M. P. (2013). Effectiveness of mangrove forests in surface wave attenuation: A review. *Research journal of applied sciences, engineering and technology*, 5(18), 4483-4488.
- Islam, M., Bhattacharya, B., & Popescu, I. (2018). Flood risk assessment due to cyclone induced dike breaching on coastal areas of Bangladesh. *Natural Hazards and Earth System Sciences Discussions*, 1-22. doi: 10.5194/nhess-2018-169.
- Jonkman, S. N., Hillen, M. M., Nicholls, R. J., Kanning, W., & Van Ledden, M. (2013). Costs of adapting coastal defences to sea-level rise—new estimates and their implications. *Journal of Coastal Research*, 29(5), 1212-1226. doi: 10.2112/JCOASTRES-D-12-00230.1.
- Jonkman, S. N., Jorissen, R. E., Schweckendiek, T., & Van den Bos, J. P. (2021). *Flood defenses - Lecture Notes CIE5314*. Delft University of Technology.
- Knabb, R. D., Rhome, J. R., & Brown, D. P. (2023). *Tropical Cyclone Report: Hurricane Katrina, 23-30 August 2005*. https://www.nhc.noaa.gov/data/tcr/AL122005_Katrina.pdf
- Lazarte, C. A., Robinson, H., Gómez, J. E., Baxter, A., Cadden, A., & Berg, R. (2015). *Geotechnical Engineering Circular no. 7 Soil Nail Walls - Reference Manual (FHWA-NHI-14-007)*. Federal Highway Administration; USA.
- Leene, L., & Broekhuis, S. (2019). *Afstudeerrapport, Reststerkte en Restcapaciteit legankerconstructies [BSc thesis - residual strength and capacity of steel tie rods]* Windesheim University of Applied Sciences].
- Lieberman, N. v., & Mai, S. (2001). Analysis of an optimal foreland design. In *Coastal Engineering 2000* (pp. 3843-3852).
- Mirza, M. M. Q., Warrick, R. A., Ericksen, N., & Kenny, G. (2001). Are floods getting worse in the Ganges, Brahmaputra and Meghna basins? *Global Environmental Change Part B: Environmental Hazards*, 3(2), 37-48.
- Monirul Qader Mirza, M. (2002). Global warming and changes in the probability of occurrence of floods in Bangladesh and implications. *Global Environmental Change*, 12(2), 127-138. doi: 10.1016/S0959-3780(02)00002-X.
- Mutton, D., & Haque, C. E. (2004). Human Vulnerability, Dislocation and Resettlement: Adaptation Processes of River-bank Erosion-induced Displacees in Bangladesh. *Disasters*, 28(1), 41-62. doi: 10.1111/j.0361-3666.2004.00242.x.
- RHDHV. (2016). *Bouwstenen voor het versterken van een dijk*.
- Steckler, M. S., Oryan, B., Wilson, C. A., Grall, C., Nooner, S. L., Mondal, D. R., Akhter, S. H., DeWolf, S., & Goodbred, S. L. (2022). Synthesis of the distribution of subsidence of

- the lower Ganges-Brahmaputra Delta, Bangladesh. *Earth-Science Reviews*, 224, 103887. doi: 10.1016/j.earscirev.2021.103887.
- Swenson, D. (2022). 052722 New Orleans levee map https://www.nola.com/052722-new-orleans-levee-map/image_4a76a432-dd3d-11ec-b287-e7695532d8dc.html
- TAW. (2004). *Technisch Rapport Kistdammen en Diepwanden in Waterkeringen*
- USACE. (2006). *Performance Evaluation of the New Orleans and Southeast Louisiana Hurricane Protection System - Draft Final Report of the Interagency Performance Evaluation Task Force.*
- USACE. (2008). *Final individual environmental report - LPV, West Return Floodwall. IER #2.* US Army Corps of Engineers.
- USACE. (2009). *inal individual environmental report supplemental- LPV, West Return Floodwall. IERS 2.a.*
- USACE. (2012). *Hurricane and Storm Damage Risk Reduction System Design Guidelines. Ch5: Structures.* <https://www.mvn.usace.army.mil/Portals/56/docs/engineering/HurrGuide/EntireDocument.pdf>
- USACE. (2019). *Best practices in dam and levee safety risk analysis. Ch. E8: Floodwalls.* Presentation: US Army Corps of Engineers. Retrieved from <https://www.usbr.gov/damsafety/risk/BestPractices/Presentations/E8-FloodwallsPP.pdf>
- USACE. (2020). *East Bank, Mississippi River Floodwall, Mississippi River and Tributaries Project (MR&T), Carrallton Phase III District Floodwall.* (Solicitation W912P8-20-B-0042). US Army Corps of Engineers.
- Van Berchum, E. C., Gijón Mancheño, A., Jonkman, S. N., Herman, P. M. J., & Kanning, W. (2020). *Enhancing Coastal Resilience in Bangladesh. Scenarios for future investments in embankments and Mapping Mangrove Opportunities.*
- Van Bergeijk, V., Warmink, J., Frankena, M., & Hulscher, S. (2019). Modelling dike cover erosion by overtopping waves: the effects of transitions. *Coastal Structures 2019*, 1097-1106.
- Van der Meer, J., Schrijver, R., Hardeman, B., van Hoven, A., Verheij, H., & Steendam, G. J. (2010). Guidance on erosion resistance of inner slopes of dikes from three years of testing with the Wave Overtopping Simulator. *Coasts, marine structures and breakwaters: Adapting to change: Proceedings of the 9th international conference organised by the Institution of Civil Engineers and held in Edinburgh on 16 to 18 September 2009,*
- Zwanenburg, S., Van Steeg, P., & Van Hoven, A. (2018). *Integrale benadering toegestaan golfoverslagdebiet.* P. Macrostablieiteit.

Appendix A: Design choices in the Gorinchem-Waardenburg project

Within the project three alternatives were defined per subsection:

- 1) Reinforcement landwards with soil.
- 2) Reinforcement towards the river with soil.
- 3) Reinforcement with construction.

The alternative ‘Reinforcement with construction’ is described in section 4.3.1, using a specific location as example. For the other two alternatives, which focus less on reducing the spatial footprint, examples and cost estimates are given below.

Reinforcement landwards with soil (cross section TG385)

At cross section TG385 the embankment is reinforced landwards with soil. The crest height is increased with ca 0.2 m. A berm with a width of 30m and a height of ca 2m is needed for stability of the inward slope. A sheet pile AZ17-700 with a length of 8.5m is needed against piping/heave. A new road is made on the foundation of the current road.

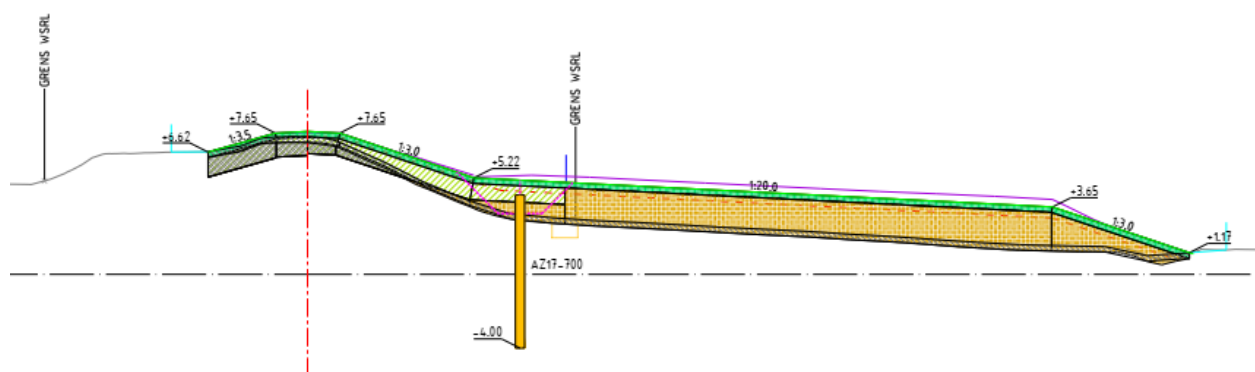

Figure 34: Reinforcement of the alternative landwards with soil (cross section TG385)

Table 6: Quantities and direct building costs per linear meter of dike for landwards with soil (cross section TG385)

Structure	Quantities	Total costs
New dike core (m ³ clay)	0	€ -
Reusable material (m ³ clay)	0	€ -
Stability berm (m ³ sand/soil)	60	€ 480
Erosion layer (m ³ clay)	20	€ 460
Top layer (m ³ soil)	15	€ 120
Sheet pile steel (tonnage)	0.88 (8.5m AZ17-700)	€ 660
Sheet pile installation (m ²)	8.5	€ 212
Anchor grout injection (m width)	0	€ -
Road (m ²)	3.5	€ 140
Road foundation (m ²)	0 (reuse of current foundation)	€ -
Land acquisition (m ²)*	33	
Total		€ 2072

* Land acquisition is not part of de direct building costs but is part of het total project costs

Reinforcement towards river with soil (cross section TG269)

At cross section TG269 the embankment is reinforced towards the river using soil. The new crest height is increased with ca 0.2 m. The crest is shifted towards the river with approximately 9 m. The current embankment is partly removed (gray area) and the materials are re-used. A berm with a width of 7 m remains of the old embankment for slope stability. The embankment in this section meets the standards concerning piping, so a sheet pile screen or other measure is not necessary. A new road with a foundation is made on the new crest.

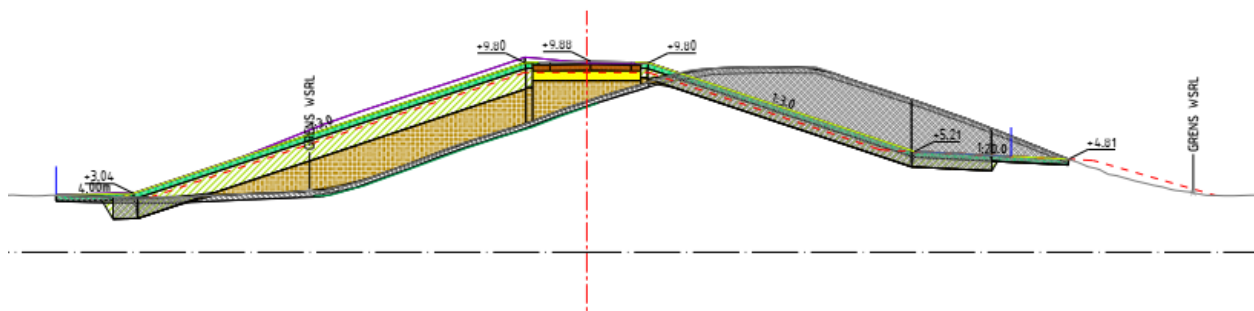

Figure 35: Reinforcement of the alternative towards river with soil (cross section TG269)

Table 7: Quantities and direct building costs per linear meter of dike for the alternative towards river with soil (cross section TG269)

Structure	Quantities	Total costs
New dike core (m ³ clay)	34	€ 680
Reusable material (m ³ clay)	28	€ -224
Stability berm (m ³ sand/soil)	0	€ -
Erosion layer (m ³ clay)	21	€ 483
Top layer (m ³ soil)	12	€ 96
Sheet pile steel (tonnage)	0	€ -
Sheet pile installation (m ²)	0	€ -
Anchor grout injection (m width)	0	€ -
Road (m ²)	3.5	€ 140
Road foundation (m ²)	4.0	€ 40
Land acquisition (m ²)*	10	
Total		€ 1.215

* Land acquisition is not part of de direct building costs but is part of het total project costs