

# SUPERSONIC WORLDPORT



COMPLEX PROJECTS  
ENERGY

P.5.0 05/07/2024

INTRODUCTION  
**CLIMATE CHANGE**

**CLIMATE CHANGE  
IS AN EXISTENTIAL  
THREAT TO EUROPE  
AND THE WORLD!**

# CLIMATE CHANGE & AVIATION INDUSTRY

**3% of global CO2  
emissions**

**EU.eu**

INTRODUCTION

# CLIMATE CHANGE & BEHAVIOUR

**“Few willing to  
change lifestyle to  
save the planet”**

**The Guardian**

**“Why people are  
not motivated to  
address climate  
change”**

**Harvard**

**“Why do we not  
act on climate  
change?”**

**Design Foundation**

INTRODUCTION  
TECHNOLOGICAL INNOVATIONS

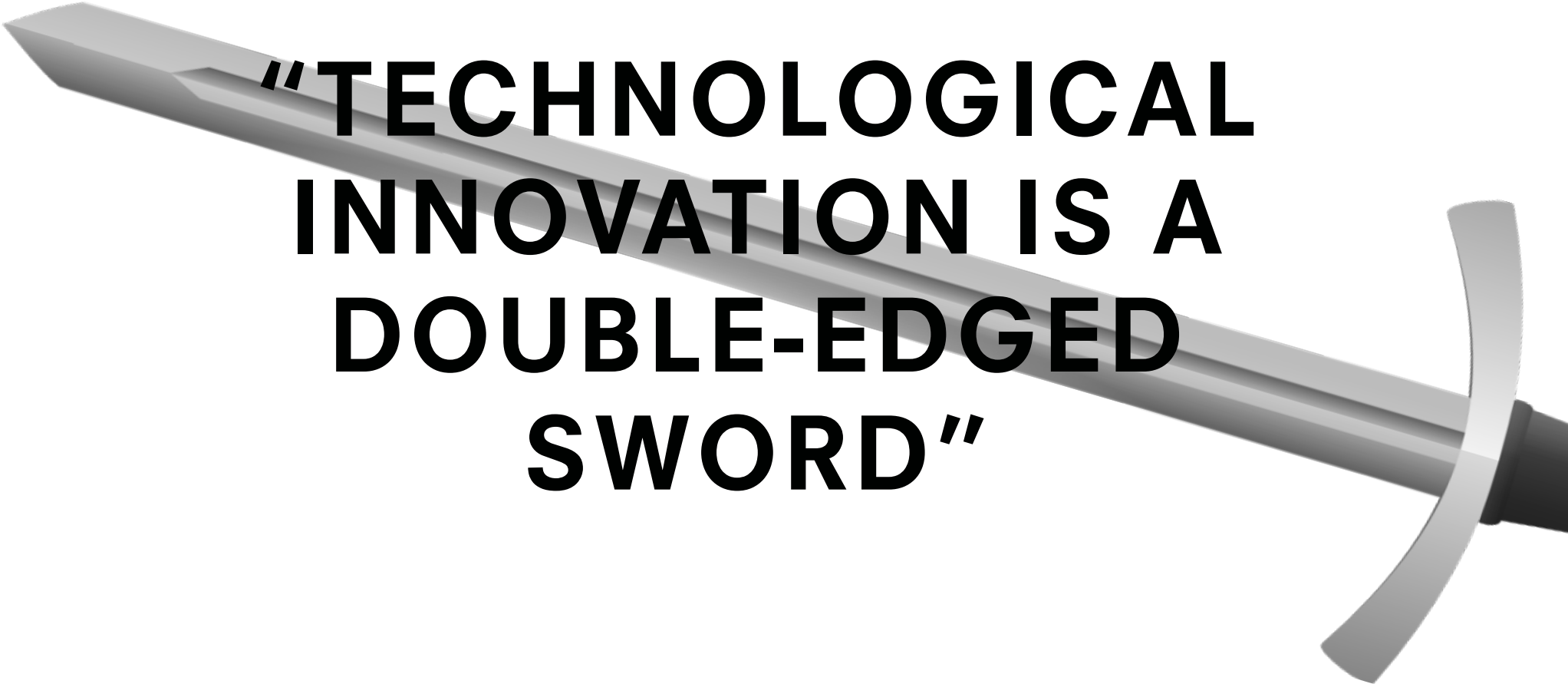

**"TECHNOLOGICAL  
INNOVATION IS A  
DOUBLE-EDGED  
SWORD"**



**TODAY LUNCH IN  
NEW YORK?  
NO PROBLEM!**

INTRODUCTION  
**FUTURE WORLD**

**7:00 A.M.**



**Berlin**

**12:00 P.M.**



**New York**

**19:00 P.M.**



**Sydney**

INTRODUCTION  
**FUTURE WORLD**

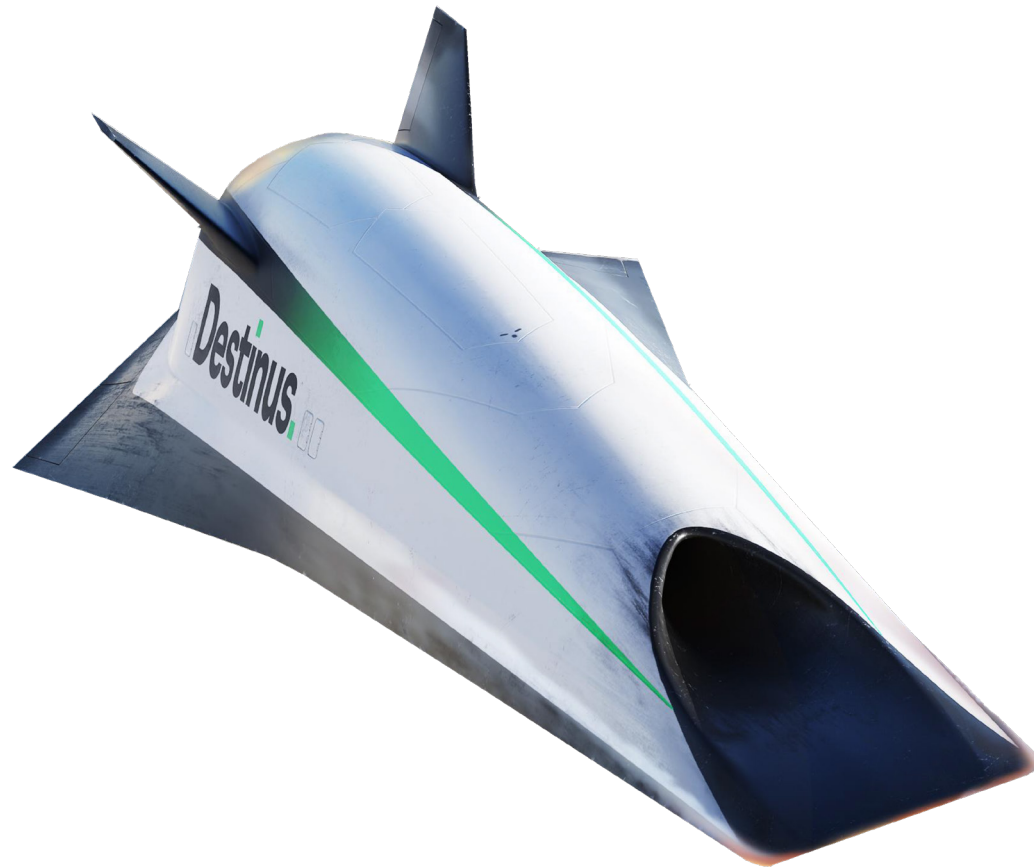

**Supersonic**

**On Hydrogen**

**CO2 neutral**



INTRODUCTION

# PASSENGER SATISFACTION

**0,5hr.**

**Time Passengers Want  
To Spend At The Airport**

**93%**

**Passengers Want  
Quicker Security**

**40%**

**Of Passengers Had Their  
Baggage Mishandled**

INTRODUCTION  
**FUTURE OF AVIATION**



**Passenger Comfort**

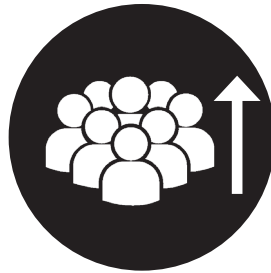

**Increasing Capacity**



**Minimizing Environmental Footprint**



**Short-haul Flights**



**Cargo Airport**



**24/7 Intercontinental**

# INTRODUCTION

## FUTURE OF AVIATION



**Passenger Comfort**

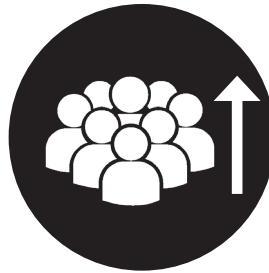

**Increasing Capacity**



**Minimizing Environmental Footprint**



**Short-haul Flights**



**Cargo Airport**



**24/7 Intercontinental**

# INTRODUCTION POLICIES

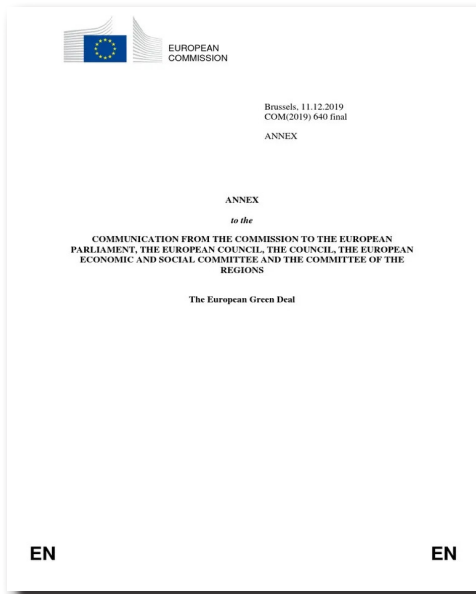
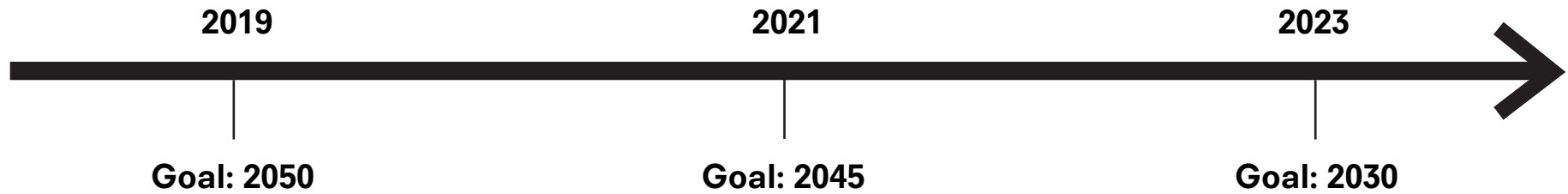

**The European Green Deal**

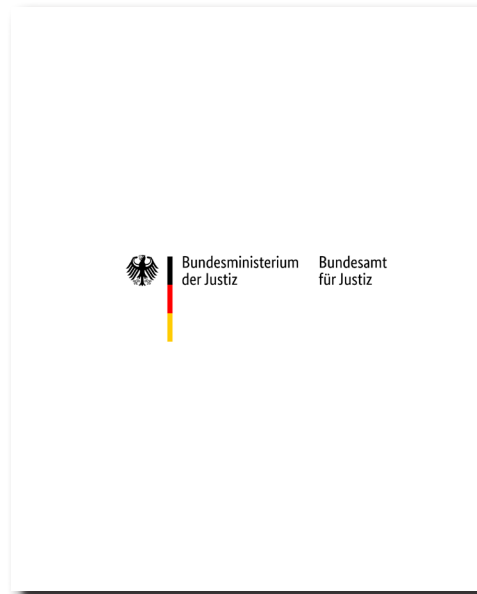

**German Climate Change Act**

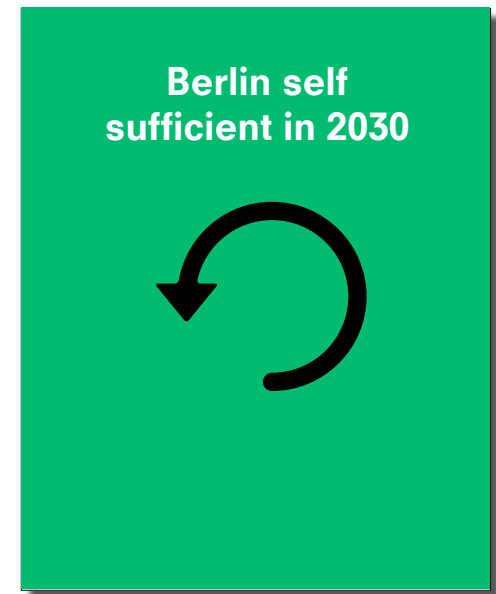

**New more ambitious policy**



## Construction of buildings

## Energy usage of buildings

## Transportation to buildings

|  |  |  |  |  |  |   |   |  |  |  |   |   |  |
|--|--|--|--|--|--|---|---|--|--|--|---|---|--|
| <p><b>R.1</b><br/>Construction site accessible from water or rail</p>          | <p><b>R.2</b><br/>Build on brownfield to prevent urban sprawl</p>          | <p><b>R.3</b><br/>Build on parking lot</p>   | <p><b>R.5</b><br/>Use electric vehicles and machines for construction processes</p>                            | <p><b>R.4</b><br/>Compact building</p>   | <p><b>R.10</b><br/>Minimise facade surface</p>   | <p><b>R.11</b><br/>Passive building to minimise heating/cooling</p>                                   | <p><b>R.12</b><br/>Use renewable sources</p>  | <p><b>R.45</b><br/>Use as little glass as possible on the north facade</p> <p><small>Loss of heat loss and little chance of heating up</small></p> | <p><b>R.46</b><br/>Drum wall, heavy wall behind the glass that absorbs heat</p>  | <p><b>R.14</b><br/>Discourage use of car by reducing car parks</p> | <p><b>R.15</b><br/>Improve pedestrian and cycle paths</p>                 | <p><b>R.16</b><br/>Multi-functional usage to prevent peaks</p>      | <p><b>R.17</b><br/>Position public buildings near mobility nodes</p> |
| <p><b>R.6</b><br/>Use energy surplus for construction</p>                      | <p><b>R.7</b><br/>Use prefabricated building elements</p>                  | <p><b>R.8</b><br/>Reuse building</p>   | <p><b>R.9</b><br/>Compact building</p>   | <p><b>R.13</b><br/>Use residual heat from the grid</p>                                 | <p><b>R.20</b><br/>Underground isolation</p>   | <p><b>R.21</b><br/>Use of solar updraft chimney</p>   | <p><b>R.22</b><br/>Self regulating building climate. Greenhouse effect in a building.</p>       | <p><b>R.47</b><br/>build with mass, church effect to retain temperature</p>  | <p><b>R.48</b><br/>Compact building, as much volume as possible with as little facade.</p> <p><small>Round corners rather than sharp corners</small></p> | <p><b>R.18</b><br/>Prevent urban sprawl</p>                        | <p><b>R.50</b><br/>Build electric car conversions stations</p>            | <p><b>R.51</b><br/>Assemble digesters to turn food waste to gas</p> | <p><b>R.52</b><br/>Turning car parks to battery banks</p>            |
| <p><b>R.56</b><br/>Energy efficiency optimization with BIM technology</p>      | <p><b>R.64</b><br/>Mass timber building</p>                                | <p><b>R.23</b><br/>Reduce hallways, as little unused space as possible</p>   | <p><b>R.24</b><br/>Programmable thermostats</p>  | <p><b>R.25</b><br/>occupancy sensors</p>   | <p><b>R.26</b><br/>smart building management systems (BMS)</p>                         | <p><b>R.49</b><br/>Grouping rooms with same heat requirement, insulating them within the building</p> | <p><b>R.53</b><br/>Use materials with better thermal performance</p>                            | <p><b>R.63</b><br/>Community re-use and repair centre</p>  | <p><b>R.65</b><br/>Adjust bike parking in building regulations to encourage biking</p>   | <p><b>R.66</b><br/>Provide shared mobility options</p>             | <p><b>R.69</b><br/>Design large storage spaces for local goods supply</p> |   |  |
| <p><b>R.27</b><br/>High-quality insulation materials, reduce heat transfer</p> | <p><b>R.28</b><br/>Windows and doors with high thermal resistance</p>      | <p><b>R.29</b><br/>Optimising building orientation with sun</p> <p><small>Orientation of buildings to receive more solar radiation</small></p> | <p><b>R.30</b><br/>Windows that capture sunlight during the winter while minimizing exposure in the summer</p> | <p><b>R.54</b><br/>Solar chimney to improve natural ventilation</p>                    | <p><b>R.55</b><br/>Revised l insulation material</p>                                   | <p><b>R.67</b><br/>Limit office space to encourage work from home</p>                                 | <p><b>R.70</b><br/>Compact program building reduce transportation needs</p>                     | <p><b>R.71</b><br/>Provide an all-day program/counter balance with nearby buildings to minimise peaks</p>  | <p><b>R.72</b><br/>Transform tradition stations to P+R stations to reduce car use</p>  |  |   |   |  |
| <p><b>R.31</b><br/>Solar panels</p>  | <p><b>R.33</b><br/>Geothermal energy</p>                                   | <p><b>R.34</b><br/>Low-flow fixtures, reduces water consumption</p>  | <p><b>R.35</b><br/>Green roof, to help heat absorption</p>   | <p><b>R.57</b><br/>Green roof &amp; facade</p>   | <p><b>R.58</b><br/>Habitable solar photovoltaics on unused mechanical roof</p>         | <p><b>R.73</b><br/>Provide the amount of e-car charging poles</p>                                     | <p><b>R.74</b><br/>Continuous walking and riding experience to stimulate walking and riding</p> |  |  |  |   |   |  |
| <p><b>R.36</b><br/>reflective roof, to help heat absorption</p>                | <p><b>R.37</b><br/>Use of surface water as a source for heat and cold</p>  | <p><b>R.39</b><br/>Tidal movements turbines to generate electricity</p>  | <p><b>R.40</b><br/>Ground heat, as a source for heat and cold</p>  | <p><b>R.59</b><br/>Sludge to energy production inside the building's toilet system</p> | <p><b>R.60</b><br/>Thermal zoning in buildings for precise heating/cooling control</p> |   |   |  |  |  |   |   |  |
| <p><b>R.41</b><br/>Sun screens</p>   | <p><b>R.42</b><br/>Shutters, to close a building when it is not in use</p> | <p><b>R.43</b><br/>Optimise element orientation to reduce heat stress</p>  | <p><b>R.44</b><br/>Optimise element orientation to reduce heat stress</p>                                      | <p><b>R.61</b><br/>Use of energy-efficient lighting technologies</p>                   | <p><b>R.62</b><br/>Solar panel facade and Solar shading</p>                            |   |   |  |  |  |   |   |  |

# INTRODUCTION

## POINT SYSTEM

### 1 point card

This card **has little impact on the design** of the building and the energy saved is almost negligible

### 2 point card

This card impacts the design and detailing of the building and the energy saved is considerable

### 3 point card

this card defines the architectural concept of the building and impacts the building's climate concept

|  |   |   |   |  |   |   |   |   |  |   |   |
|--|---|---|---|--|---|---|---|---|--|---|---|
| <p><b>R.1</b><br/>Construction site accessible from water or rail</p>          | <p><b>R.2</b><br/>Build on brownfield to prevent urban sprawl</p>     | <p><b>R.3</b><br/>Build on parking lot</p>                      | <p><b>R.5</b><br/>Use electric vehicles and machines for construction processes</p>                             | <p><b>R.4</b><br/>Compact building</p>   | <p><b>R.10</b><br/>Minimise facade surface</p>                        | <p><b>R.11</b><br/>Passive building to minimize heating/cooling</p> | <p><b>R.12</b><br/>Use renewable sources</p>  | <p><b>R.14</b><br/>Discourage use of car by reducing carparks</p>     | <p><b>R.15</b><br/>Improve pedestrian and cycle paths</p>                              | <p><b>R.16</b><br/>Multi-functional usage to prevent peaks</p>  | <p><b>R.17</b><br/>Position public buildings near mobility nodes</p>                  |
| <p><b>R.6</b><br/>Use energy surplus for construction</p>                      | <p><b>R.7</b><br/>Use prefabricated building elements</p>             | <p><b>R.8</b><br/>Reuse building</p>                            | <p><b>R.9</b><br/>Compact building</p>  | <p><b>R.13</b><br/>Use residual heat from the grid</p>                         | <p><b>R.20</b><br/>Underground isolation</p>                          | <p><b>R.21</b><br/>Use of solar updraft chimney</p>                 | <p><b>R.22</b><br/>Self regulating building climate. Greenhouse effect in a building.</p>                       | <p><b>R.18</b><br/>Prevent urban sprawl</p>                           | <p><b>R.50</b><br/>Build electric car conversions stations</p>                         | <p><b>R.51</b><br/>Anaerobic digesters to turn food waste to gas</p>                                      | <p><b>R.52</b><br/>Turning car parks to battery banks</p>                             |
| <p><b>R.56</b><br/>Energy efficiency optimization with BIM technology</p>      | <p><b>R.64</b><br/>Mass timber building</p>                           | <p><b>R.25</b><br/>occupancy sensors</p>                        | <p><b>R.26</b><br/>smart building management systems (BMS)</p>  | <p><b>R.23</b><br/>Reduce hallways, as little unused space as possible</p>     | <p><b>R.24</b><br/>Programmable thermostats</p>                       | <p><b>R.25</b><br/>occupancy sensors</p>                            | <p><b>R.26</b><br/>smart building management systems (BMS)</p>  | <p><b>R.63</b><br/>Community re-use and repair centre</p>             | <p><b>R.65</b><br/>Adjust bike parking in building regulations to encourage biking</p> | <p><b>R.66</b><br/>Provide shared mobility options</p>  | <p><b>R.69</b><br/>Design large storage spaces for local goods supply</p>             |
| <p><b>R.27</b><br/>High-quality insulation materials, reduce heat transfer</p> | <p><b>R.28</b><br/>Windows and doors with high thermal resistance</p> | <p><b>R.29</b><br/>Optimizing building orientation with sun</p> | <p><b>R.30</b><br/>Windows that capture sunlight during the winter while minimizing exposure in the summer.</p> | <p><b>R.27</b><br/>High-quality insulation materials, reduce heat transfer</p> | <p><b>R.28</b><br/>Windows and doors with high thermal resistance</p> | <p><b>R.29</b><br/>Optimizing building orientation with sun</p>     | <p><b>R.30</b><br/>Windows that capture sunlight during the winter while minimizing exposure in the summer.</p> | <p><b>R.67</b><br/>Limit office space to encourage work from home</p> | <p><b>R.70</b><br/>Compact program building reduce transportation needs</p>            | <p><b>R.71</b><br/>Provide an all-day program/counter balance with nearby buildings to minimise peaks</p> | <p><b>R.72</b><br/>Transform tradition stations to P+R stations to reduce car use</p> |

# INTRODUCTION

## SPECIAL CARDS

### collab card

some strategies strengthen each other,  
which is expressed through this card.  
(Solar panels and green roof)



### power-up card

The project's main card. An energy  
concept that defines the buildings'  
concept, is a large energy saver and  
impacts architectural expression (worth  
10 points)



### conflict card

some strategies don't work together,  
which is expressed through this card  
(minimize facade surface and maximize  
heat usage from solar radiation)



INTRODUCTION  
**PROJECT HORIZON 2021-2027**



**EUROPEAN UNION**



**Scientific Impact**



**Sustainable Development**

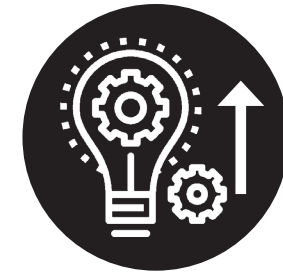

**Innovation Growth**



INTRODUCTION  
**PROJECT AMBITION**



**Sustainable Development**

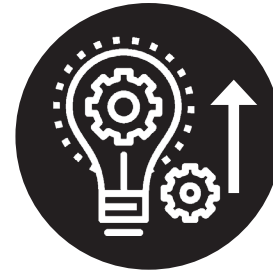

**Innovation Growth**



**Connecting The World**

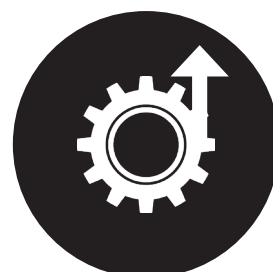

**Efficiency**

INTRODUCTION  
**RESEARCH QUESTION**

**HOW TO DESIGN  
AN AIRPORT TO  
ACCOMMODATE  
RECONFIGURATED  
EUROPEAN AVIATION  
INDUSTRY?**

01 INTRODUCTION

**02 RESEARCH  
& DESIGN BRIEF**

04 CONCEPT

05 IMPLEMENTATION

06 DEVELOPMENT

07 CONCLUSION

RESEARCH  
**FINANCE**



**Scientific Impact**



**Sustainable Development**

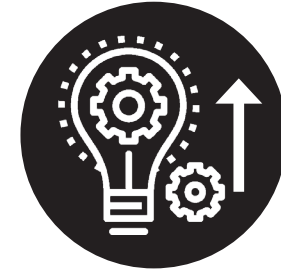

**Innovation Growth**

**PROJECT HORIZON 2021-2027**



**CLEAN AVIATION**  
**€ 4.1 BILLION BUDGET**

# EU & FUTURE SPEED RAILWAY

- Current HS Railway
- 2030 scenario
- 2050 scenario extended
- 2050 scenario
- 2050 scenario with future EU candidates

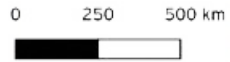

RESEARCH  
**LONG HAUL FLIGHTS**

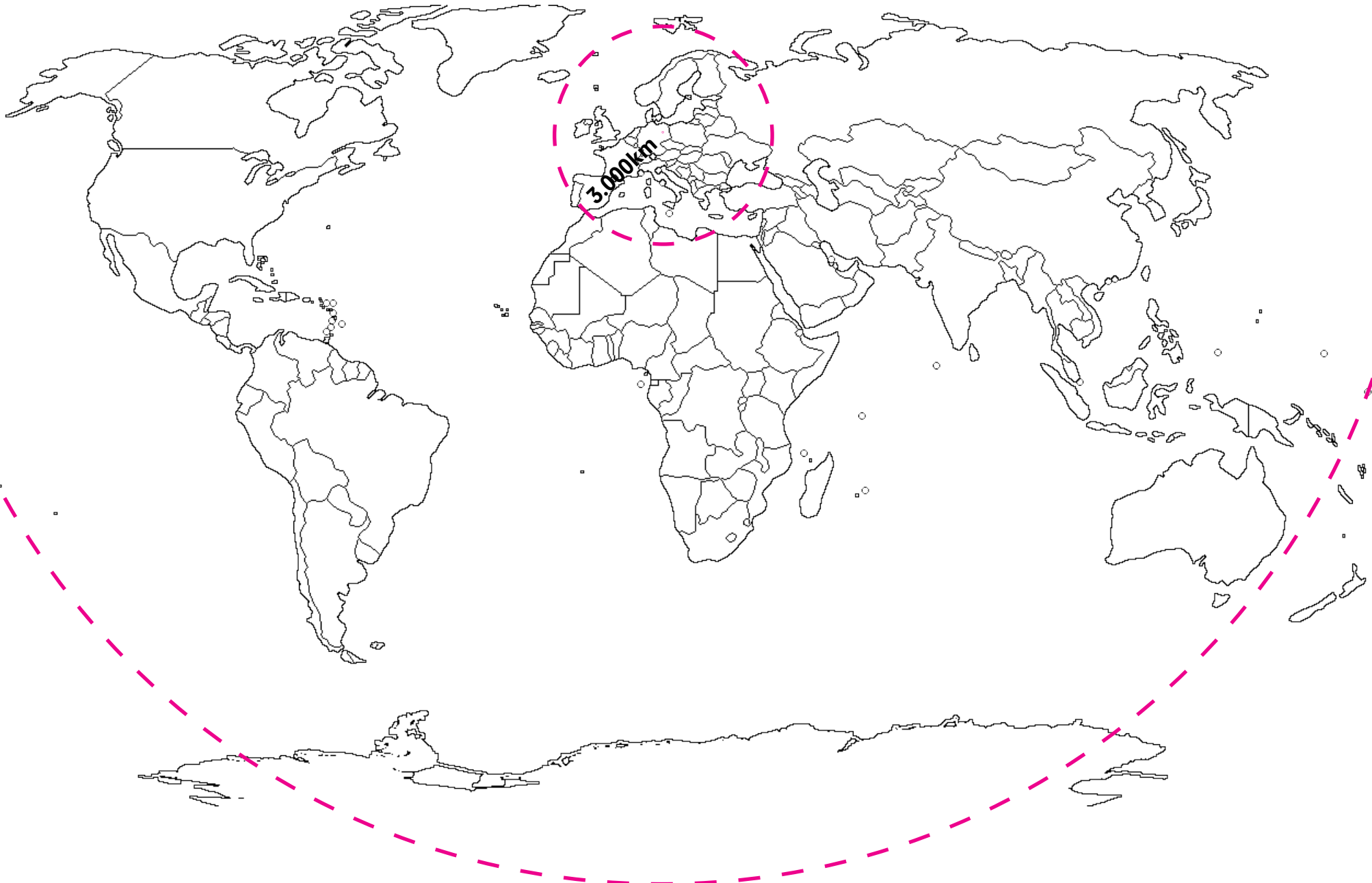

RESEARCH  
**SCHIPHOL TO BERLIN CENTRE**

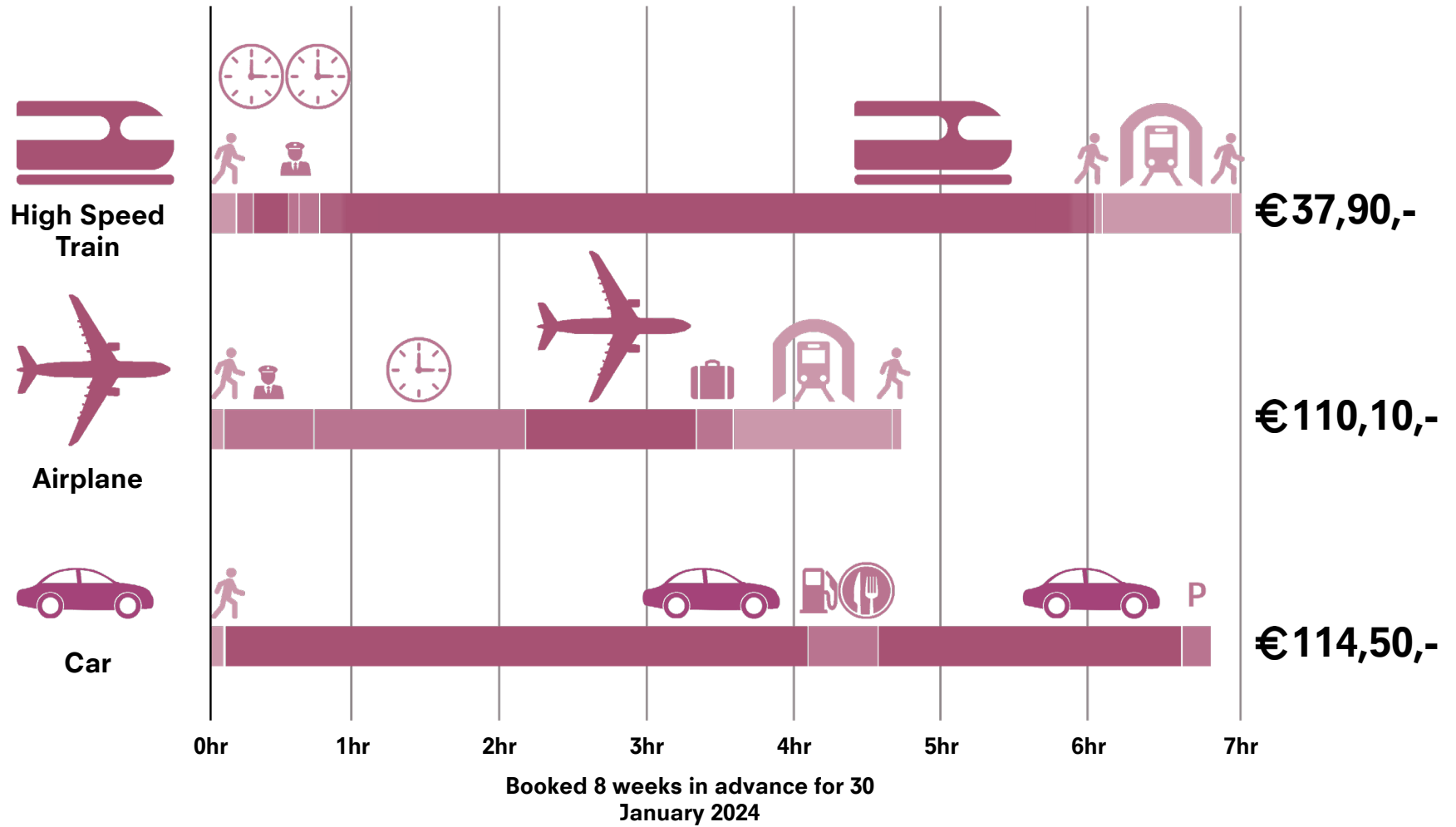

# RAILWAY & SUPERSONICS

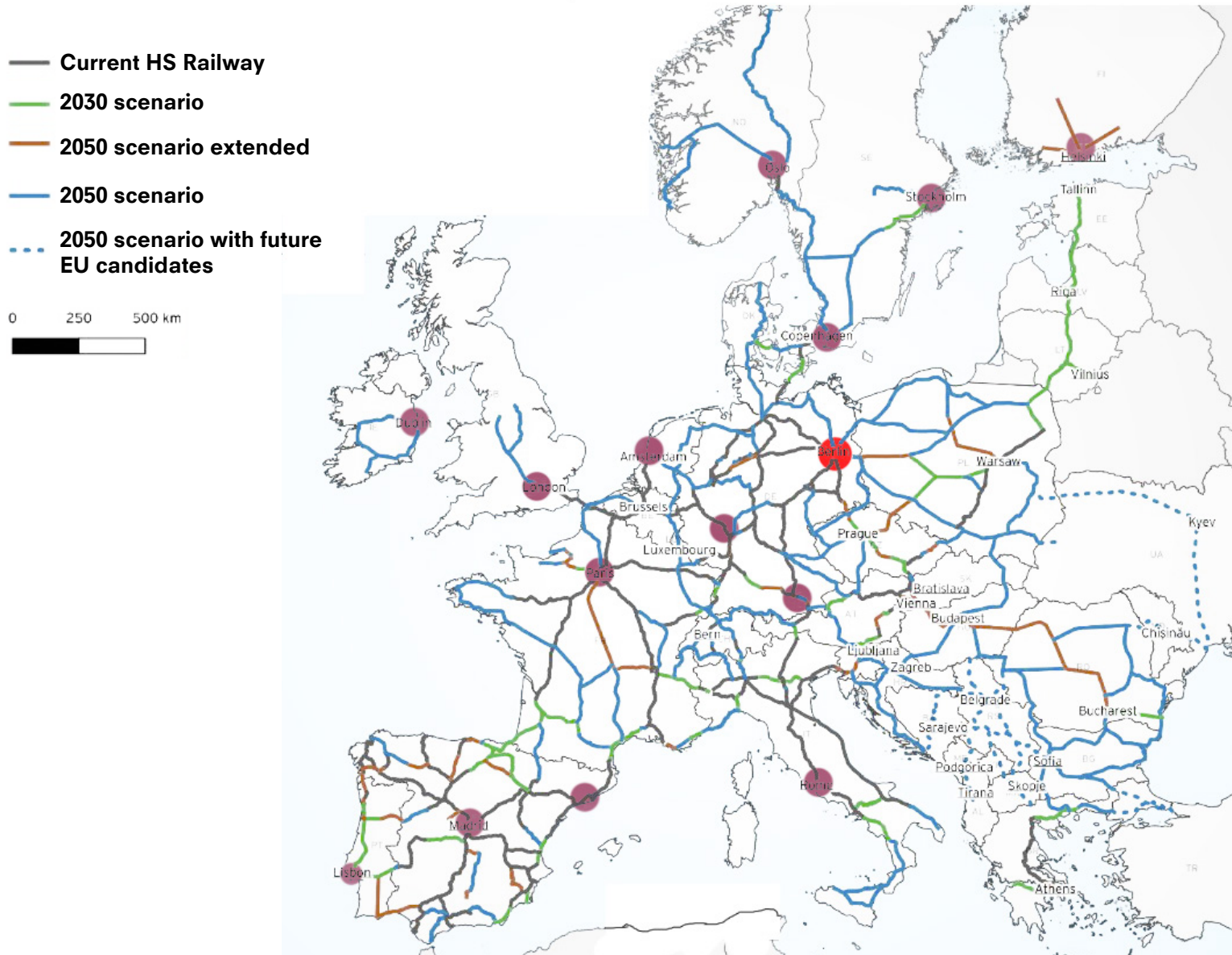



DESIGN BRIEF  
**STATE & PRIVATE**

**50%**

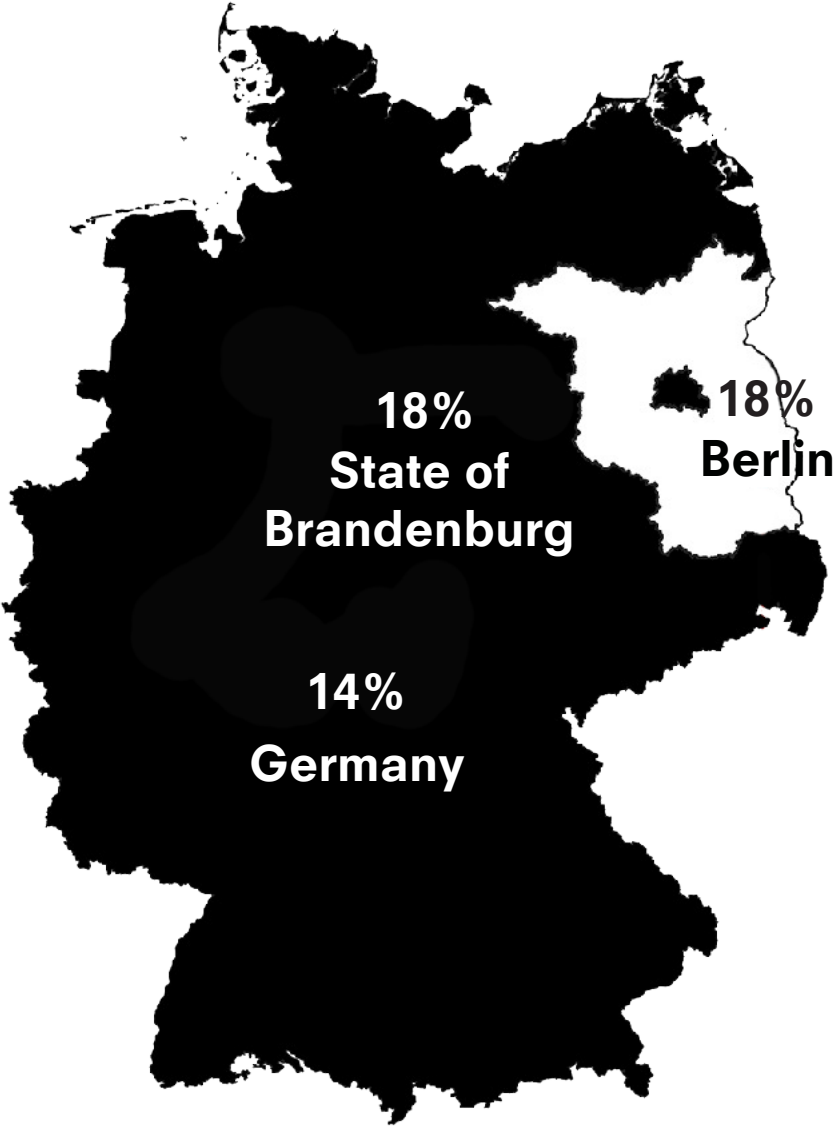

**50%**

 **Lufthansa** 15%

  
**Destinus.** 10%

**Hydrogen  
Airport** | 10%

**MICRO-X** 5%

**MATERNA  
IPS** intelligent  
passenger  
solutions 5%

  
**MORPHO DYS** 5%

DESIGN BRIEF  
**PRIVATE**

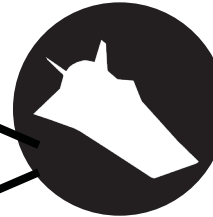

**5x Speed Of Sound**

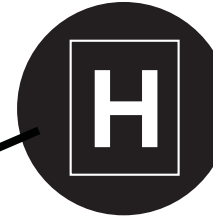

**Hydrogen Fuel**

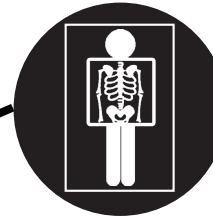

**Screening In 30 Sec**

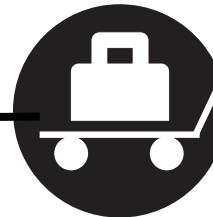

**Automated & Traced  
Baggage Handling**

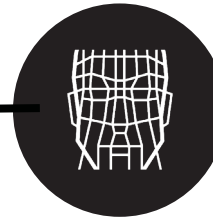

**Biometric E-Gate**



PROGRAM RESEARCH  
**REFERENCE PROJECTS**

**Schiphol**



**Frankfurt**



**Heathrow**



**Fiumicino**



**Singapore**



**Hartsfield-Jackson**



PROGRAM RESEARCH  
**REFERENCE PROJECTS - DATA**

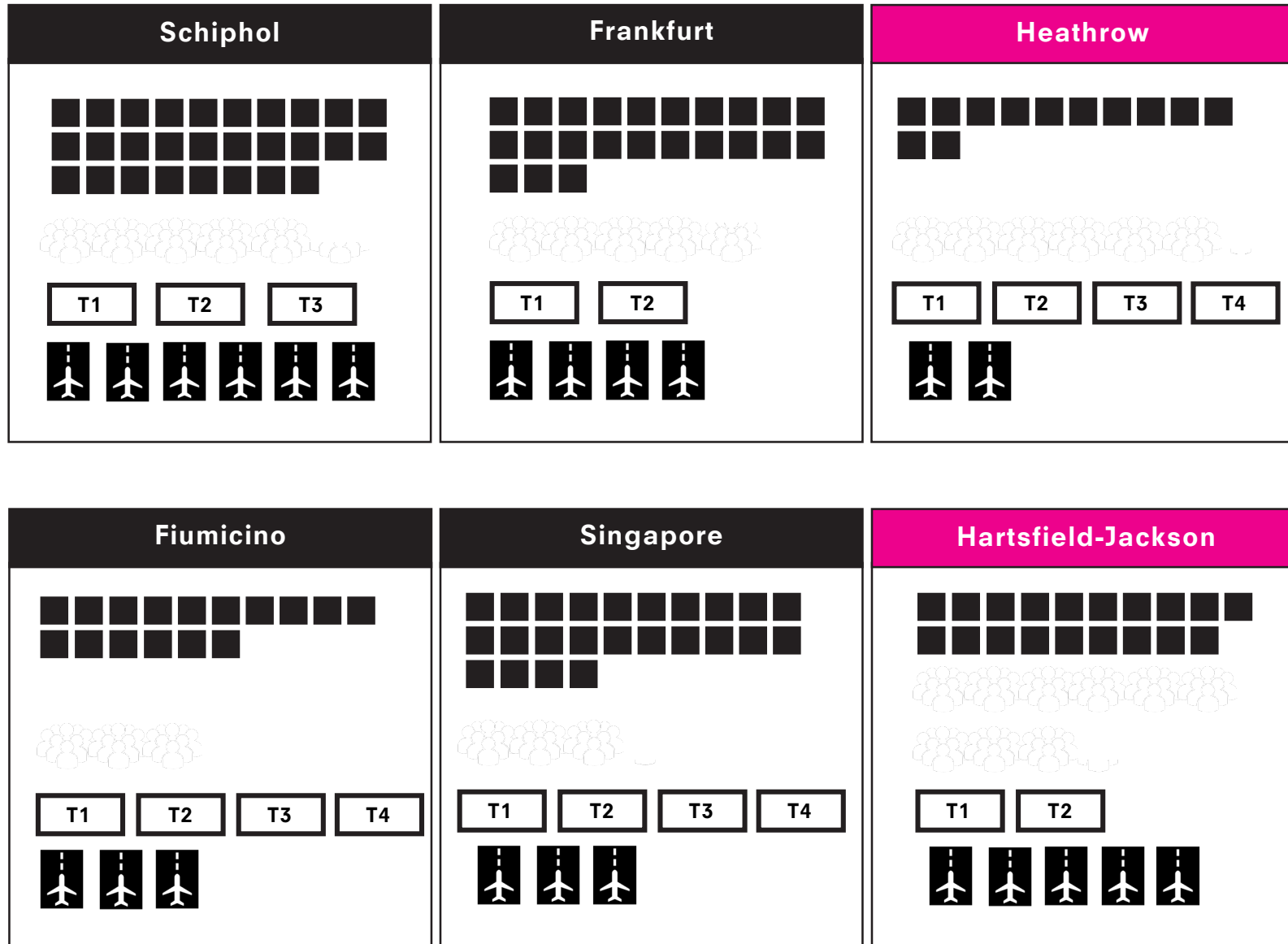

1 KM2
  10 MIL.
 T1 TERMINAL BUILDING
  RUNWAY
  MOST EFFICIENT ACCORDING TO DATA

# REFERENCE PROJECT - HARTSFIELD JACKSON AIRPORT

|                   | Total<br>117.500m <sup>2</sup><br>100% |       |
|-------------------|--|-------|
| baggage pick-up   | 3.643M <sup>2</sup>                    | 3,1%  |
| toilets           | 4.348M <sup>2</sup>                    | 3,7%  |
| security          | 4.583M <sup>2</sup>                    | 3,9%  |
| gates             | 5.875M <sup>2</sup>                    | 5,0%  |
| check-in          | 11.398M <sup>2</sup>                   | 9,7%  |
| back of the house | 12.103M <sup>2</sup>                   | 10,3% |
| shops and food    | 19.270M <sup>2</sup>                   | 16,4% |
| waiting           | 24.675M <sup>2</sup>                   | 21,0% |
| flow              | 31.605M <sup>2</sup>                   | 26,9% |

117.500  
m<sup>2</sup>

20.240.000

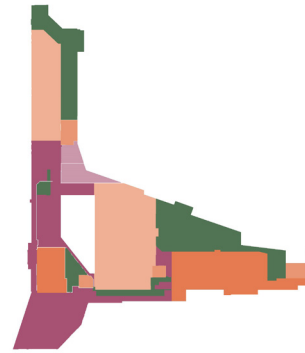
1st Floor - Arrivals



Terminal F - 1st Floor

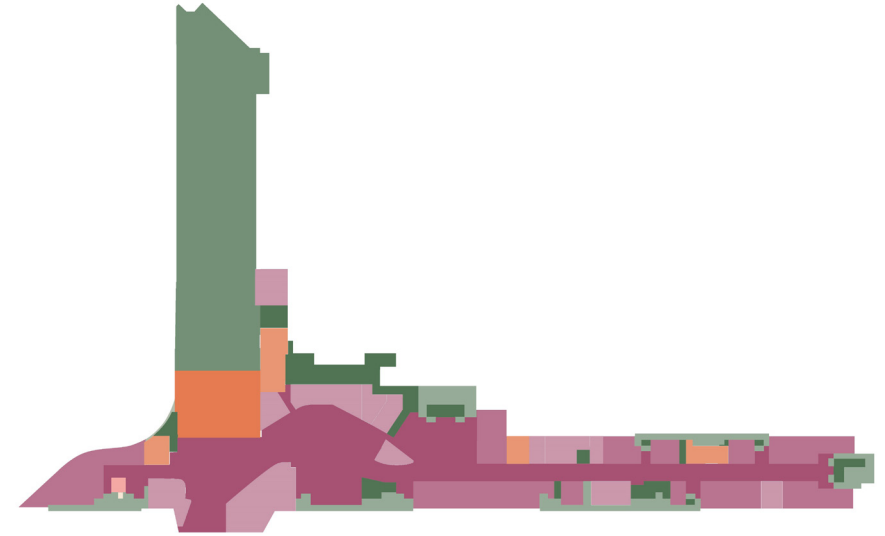

Ground Floor

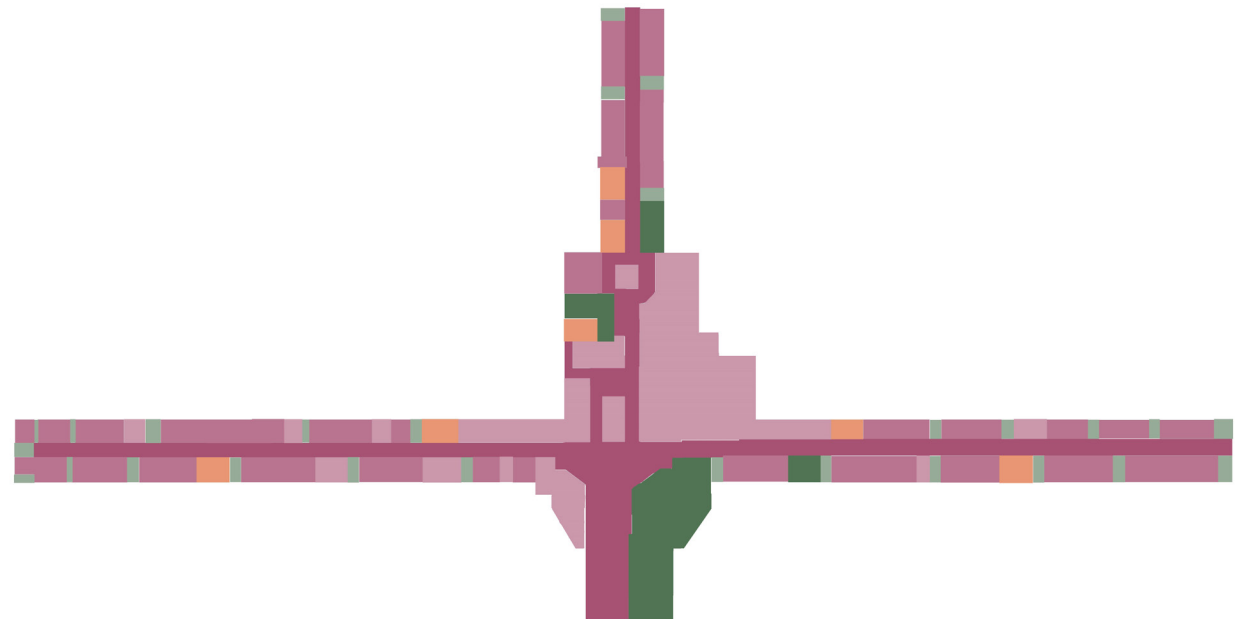

Terminal E - 1st Floor

# REFERENCE PROJECTS - HEATHROW AIRPORT

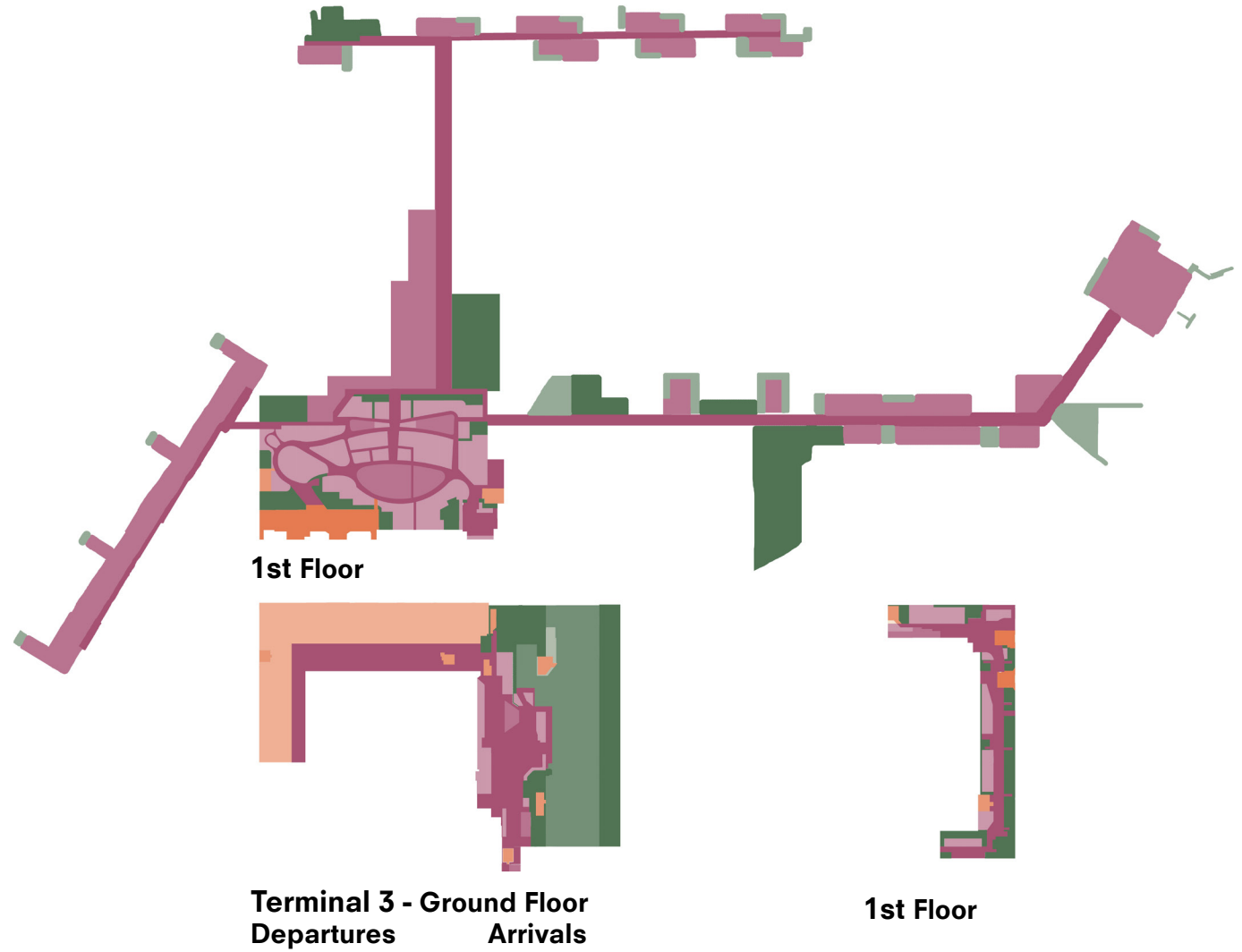
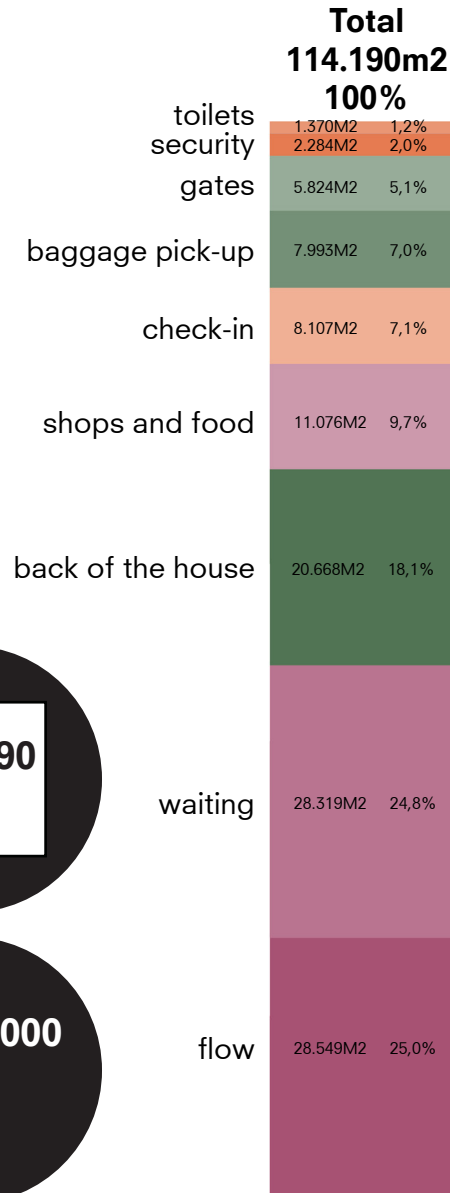

# PROGRAM RESEARCH

## REFERENCE PROJECTS

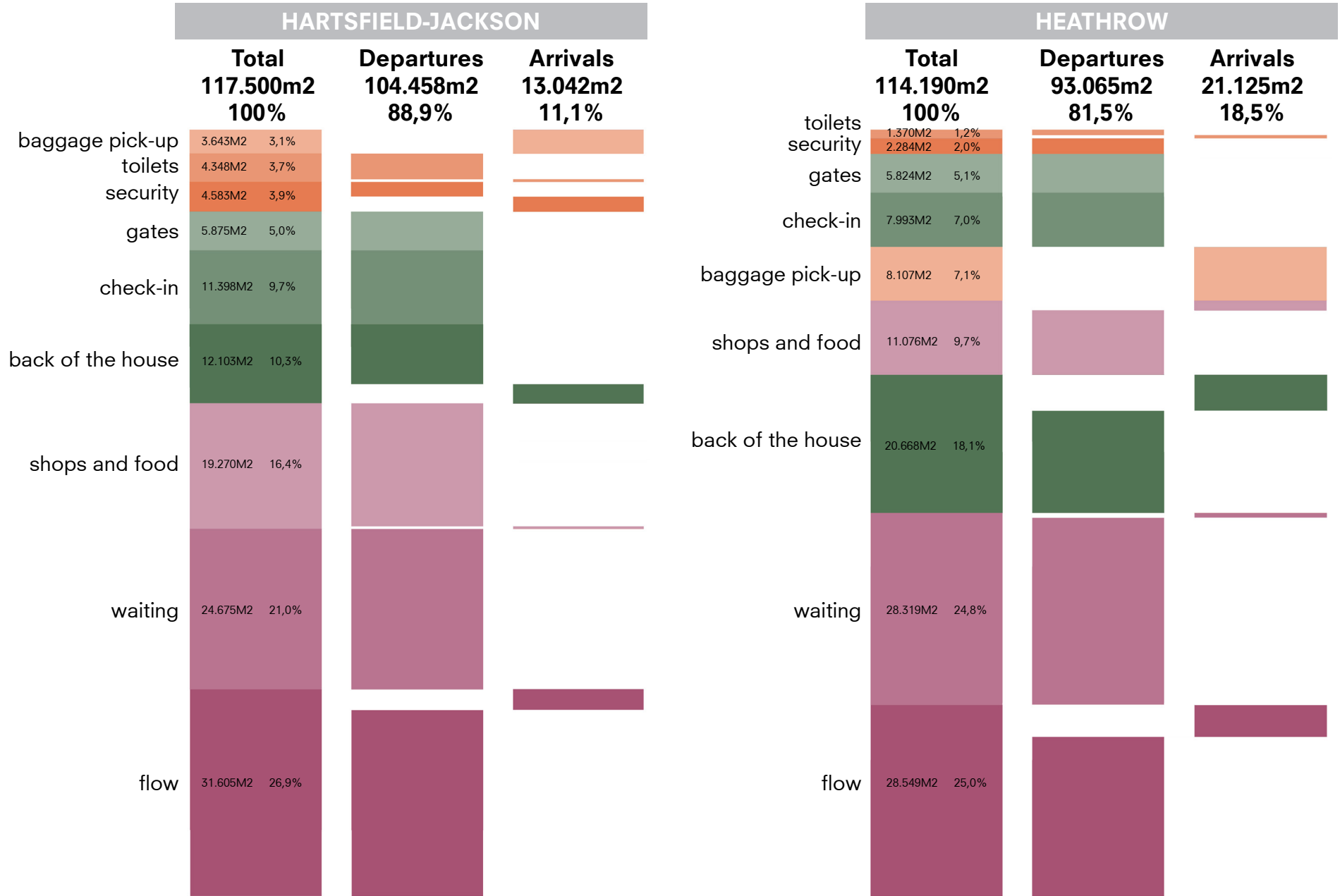

PROGRAM RESEARCH

# FROM REFERENCES TO SUPERSONIC

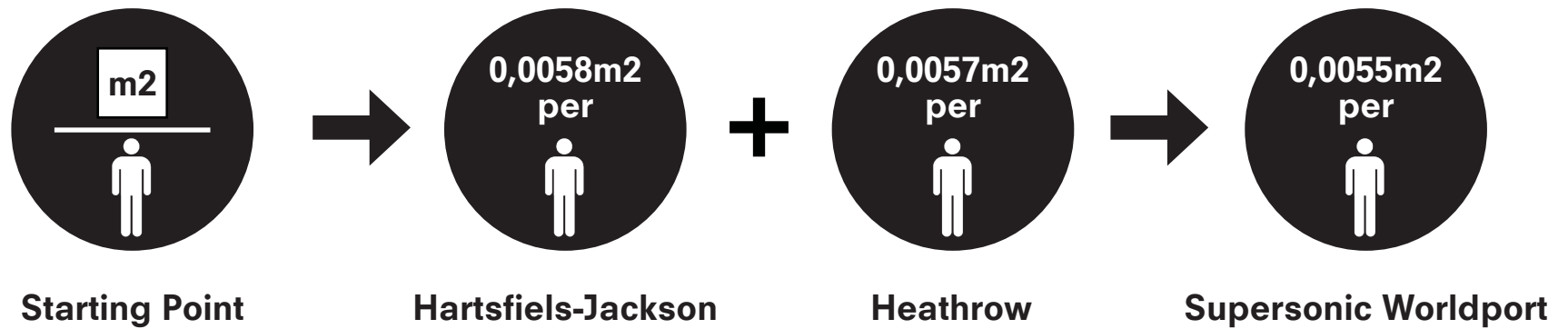



PROGRAM RESEARCH

# FROM REFERENCES TO SUPERSONIC



**Intercontinental Passengers  
In Year 2030**

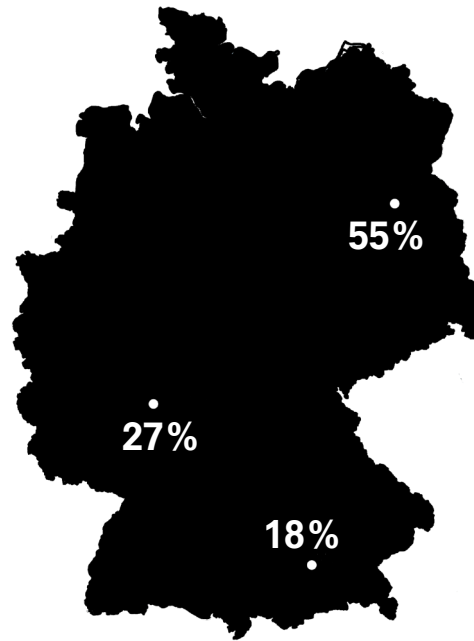

**Division**



**Supersonic Worldport**

# FROM REFERENCES TO SUPERSONIC

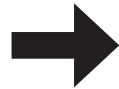

Total  
211.750m2  
100%

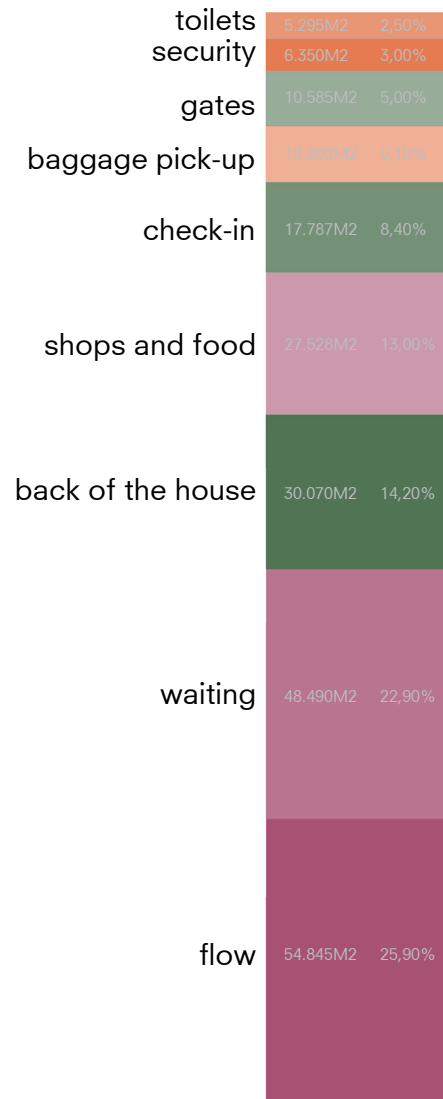

PROGRAM RESEARCH  
**INNOVATIONS**



**Hydrogen Fuel**



**5x Speed Of Sound**



**Biometric E-Gate**



**Automated & Traced  
Baggage Handling**

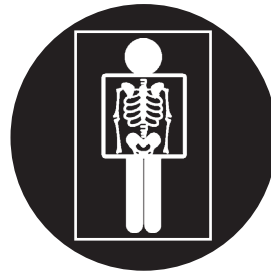

**Screening In 30 Sec**



**Reserve & Collect**

PROGRAM DESIGN BRIEF  
**HYDROGEN FUEL**



PROGRAM DESIGN BRIEF  
**CO2 NEUTRAL FUEL - HYDROGEN**



**ON SITE ELECTROLYSIS AND LIQUEFACTION**

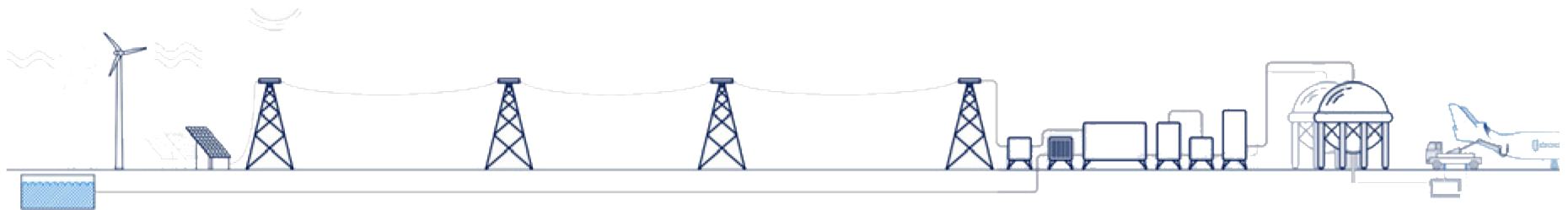
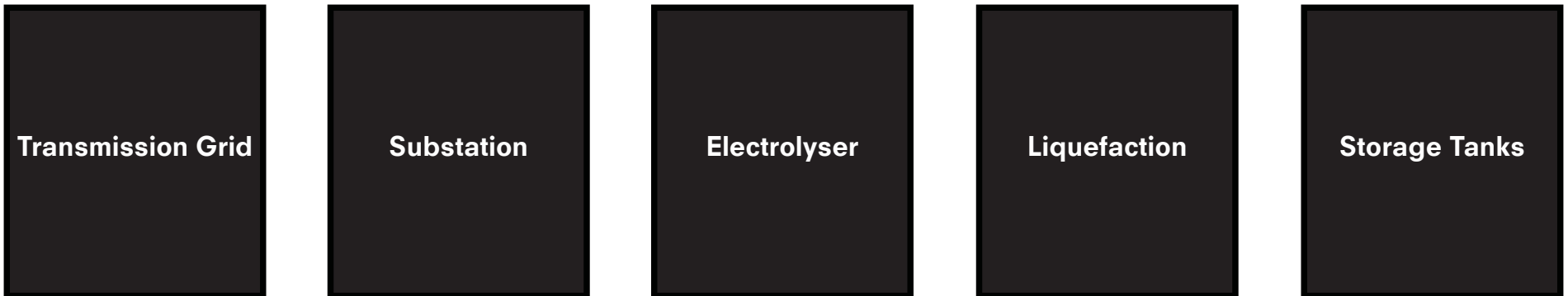

# CO2 NEUTRAL FUEL - HYDROGEN



**130.000M2**

# AIRPLANES

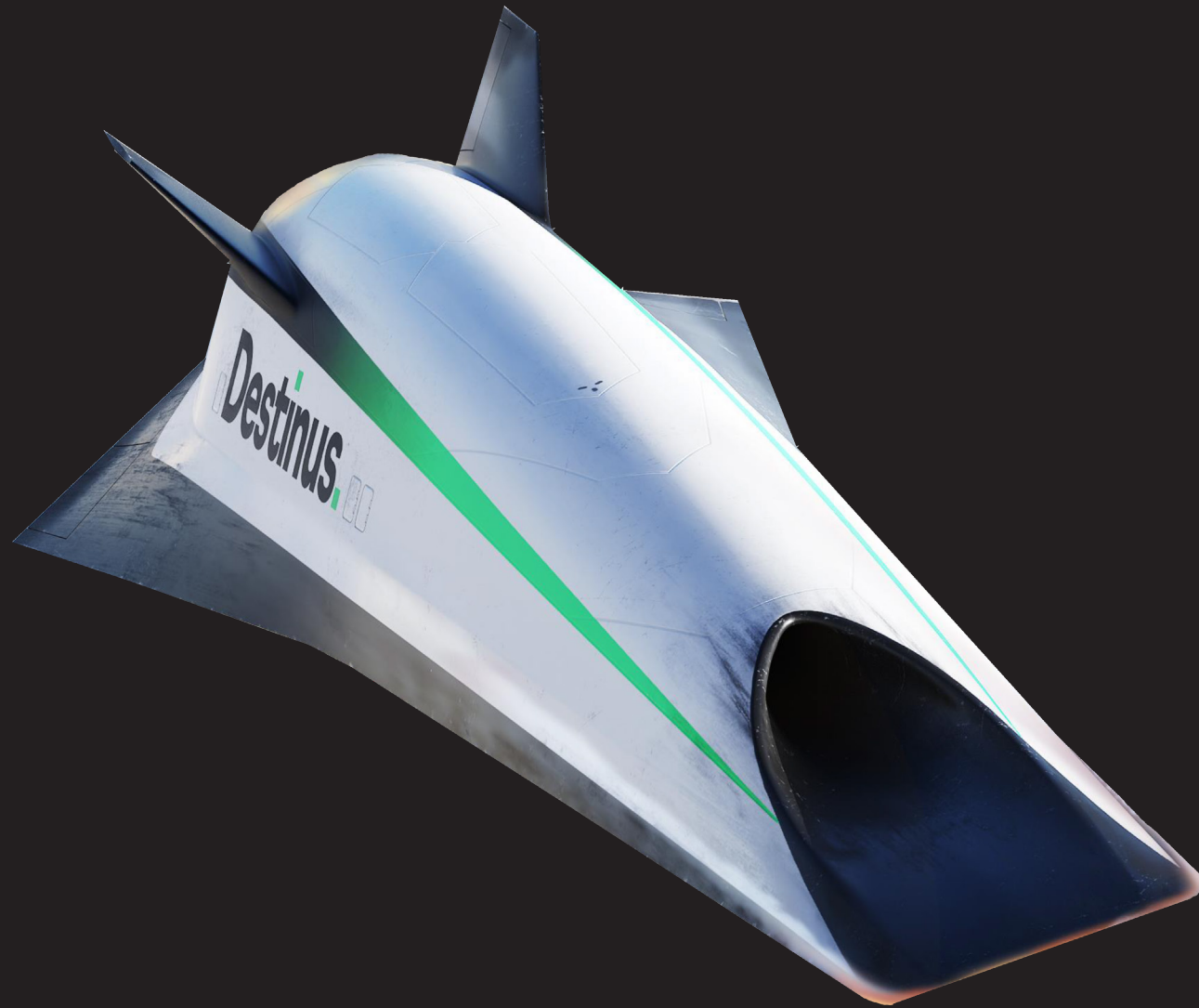

# AIRPLANES

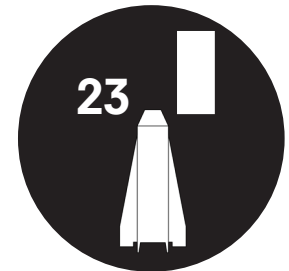
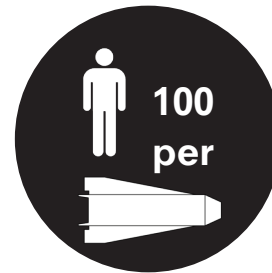



# BOEING & SUPERSONIC COMPARISON

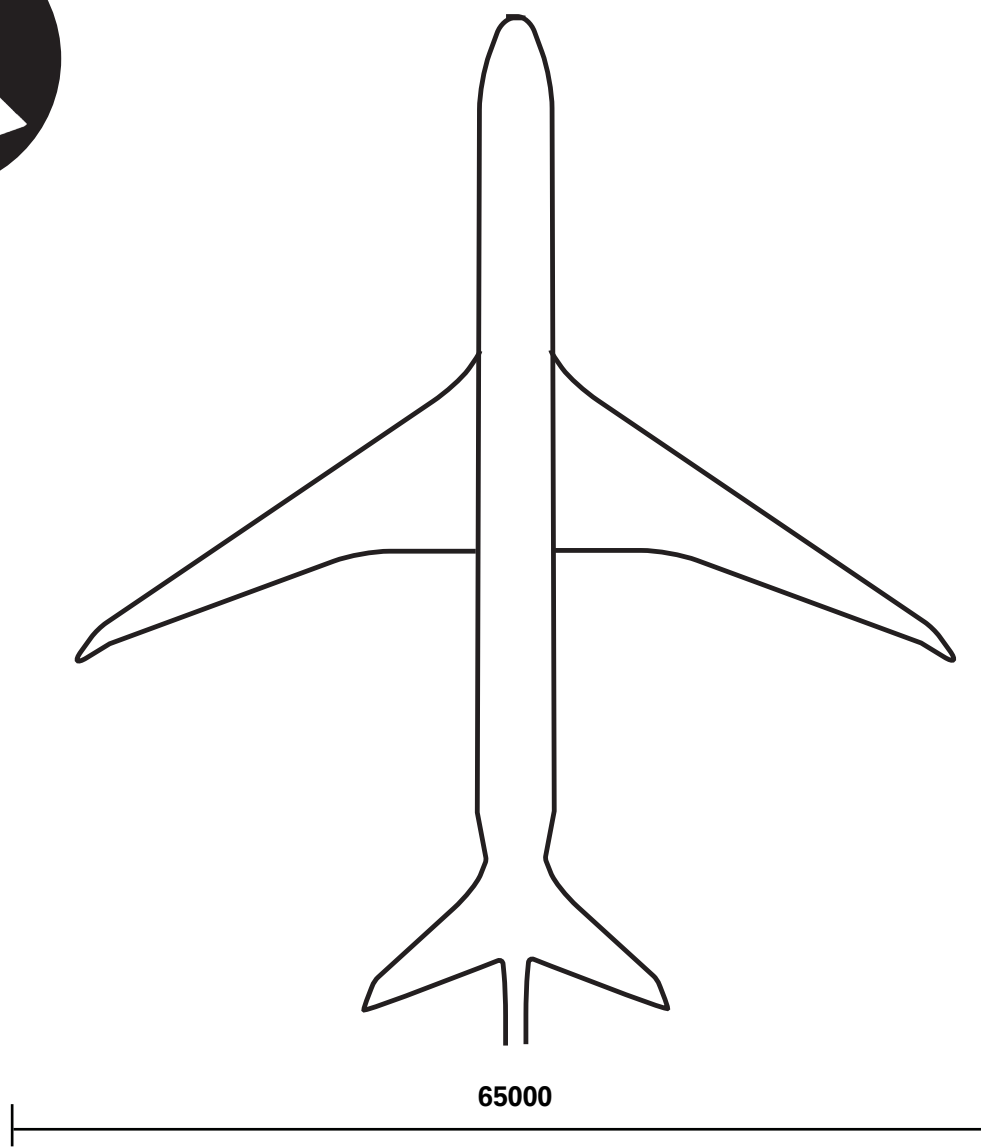

boeing 777-300er

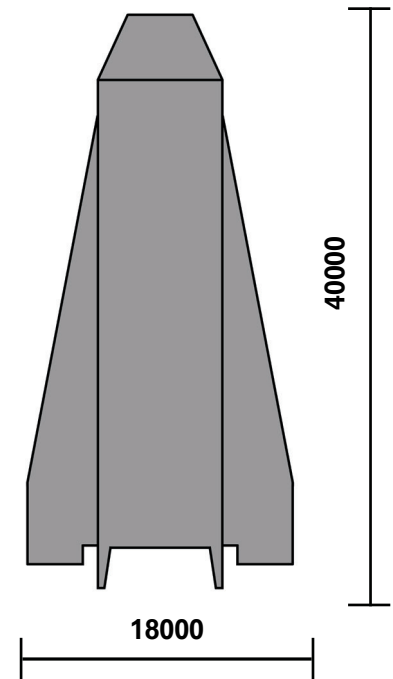

supersonic airplane

# CONCEPT AIRPLANES

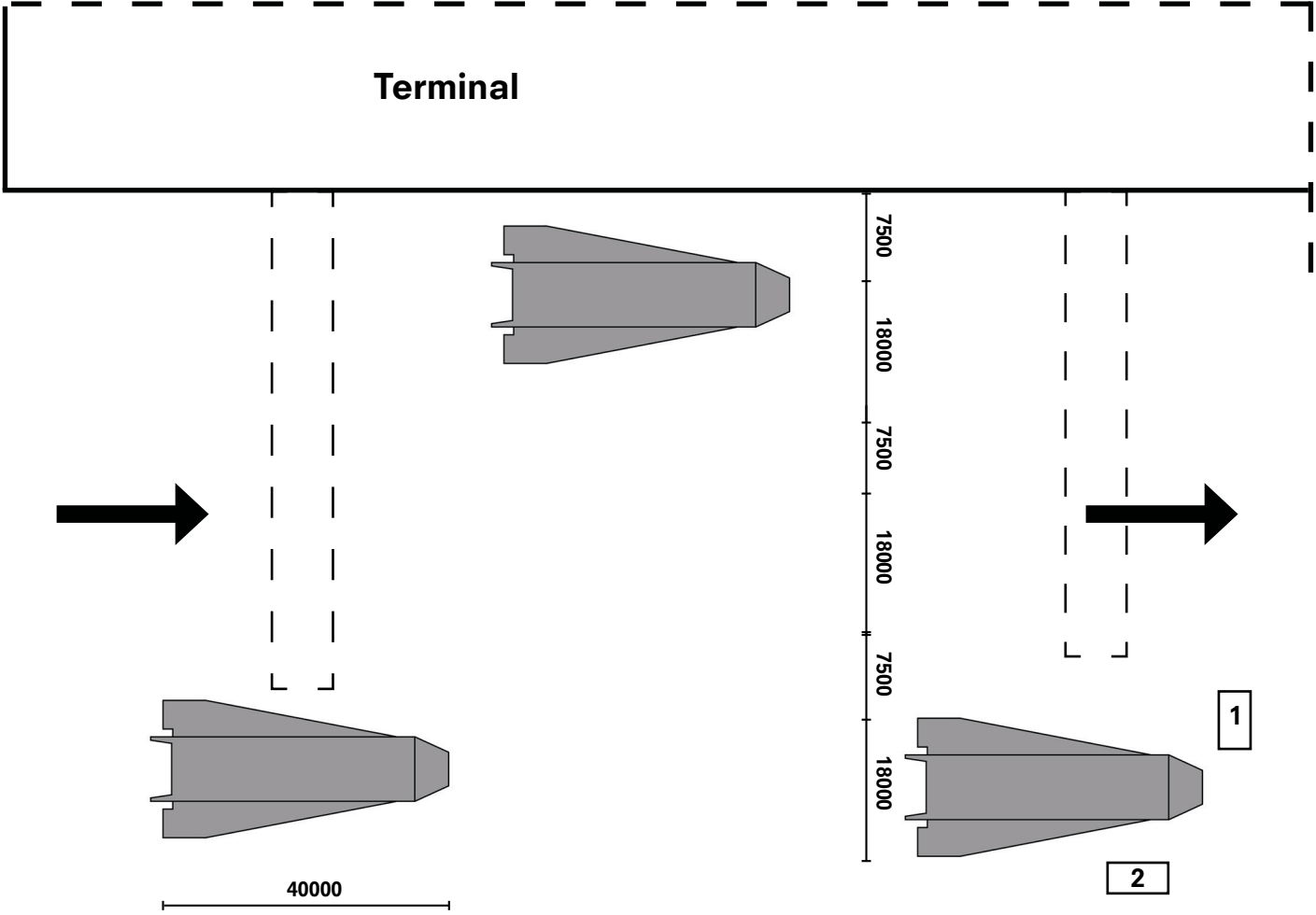

supersonic airplane

- 1 ground power unit
- 2 lavatory truck

# AIRPLANES

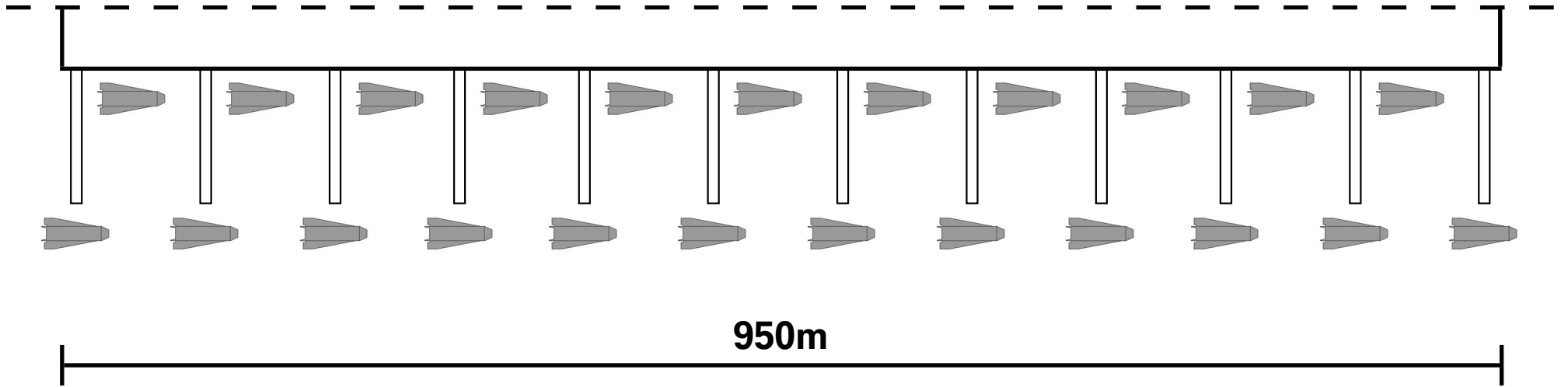

# AIRPLANES



**3.000m - 4.000m**



# E-GATE



# E-GATE

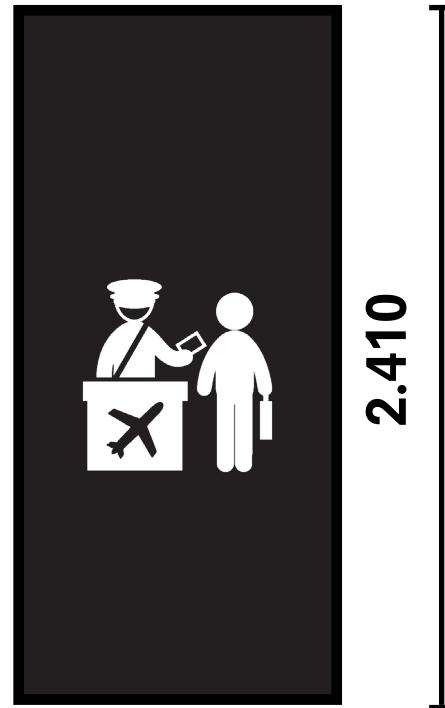

1.200



1x

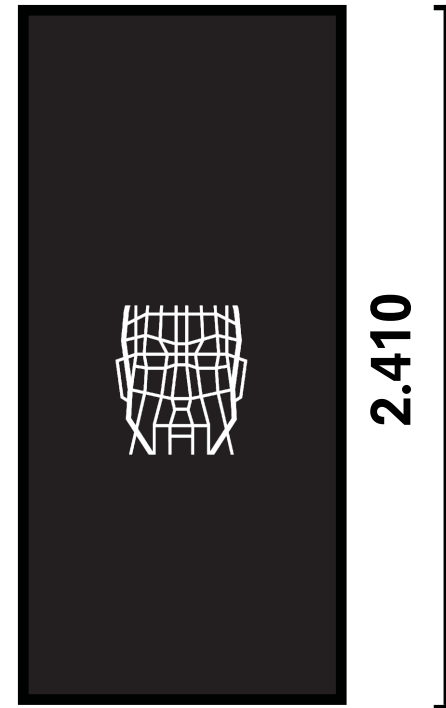

1.060



5x

# E-GATE

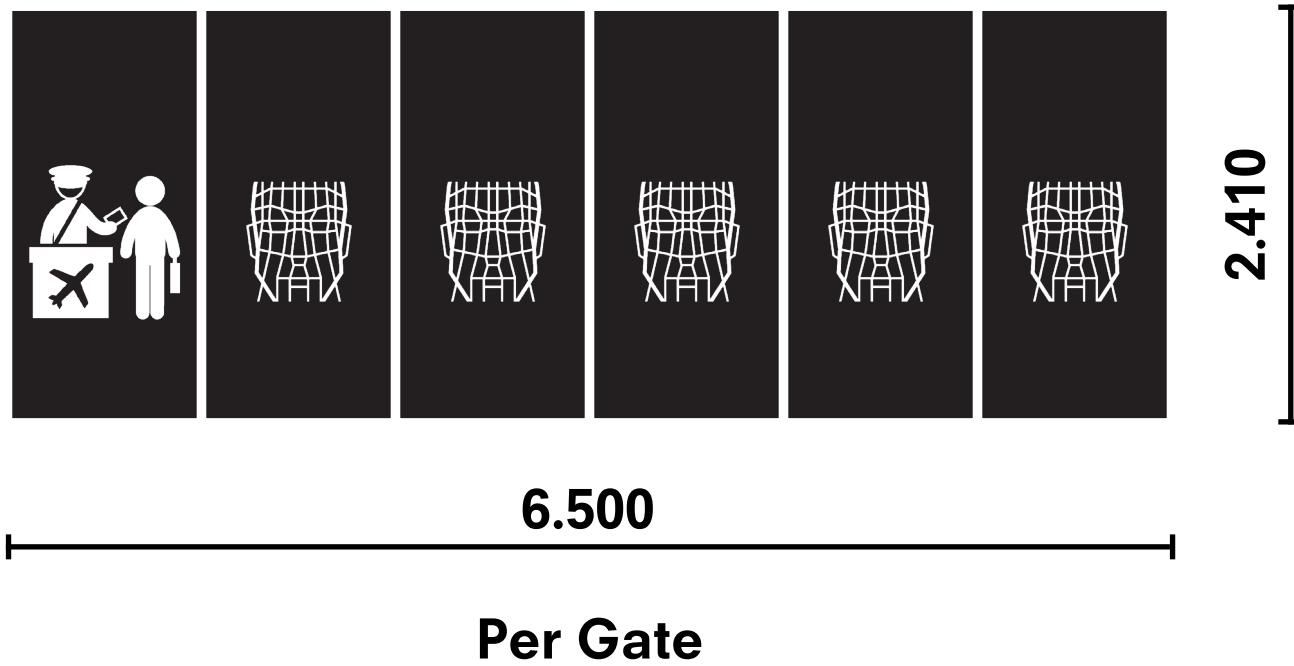

# BAGGAGE

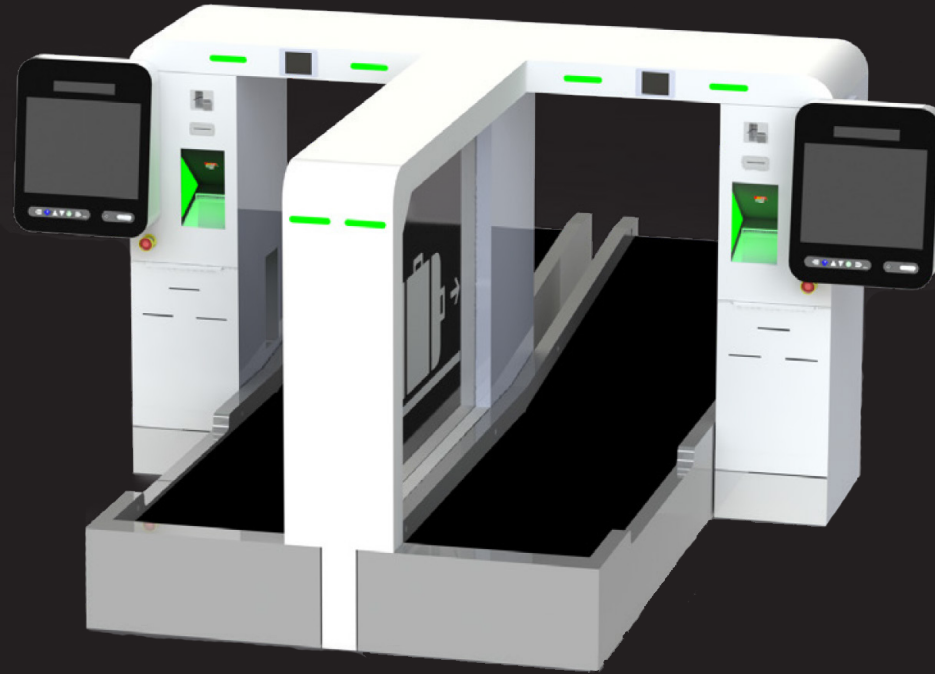



PROGRAM DESIGN BRIEF  
**BAGGAGE CHECK IN**

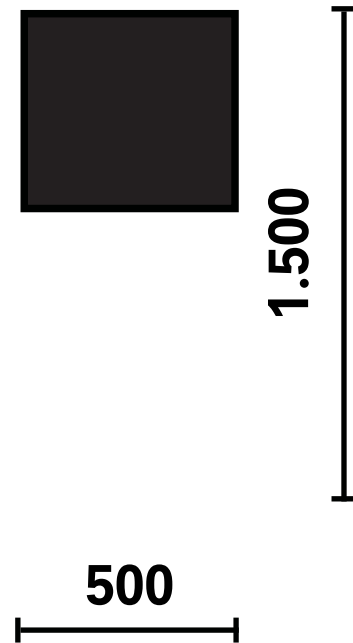

PROGRAM DESIGN BRIEF  
**BAGGAGE DROP OFF**

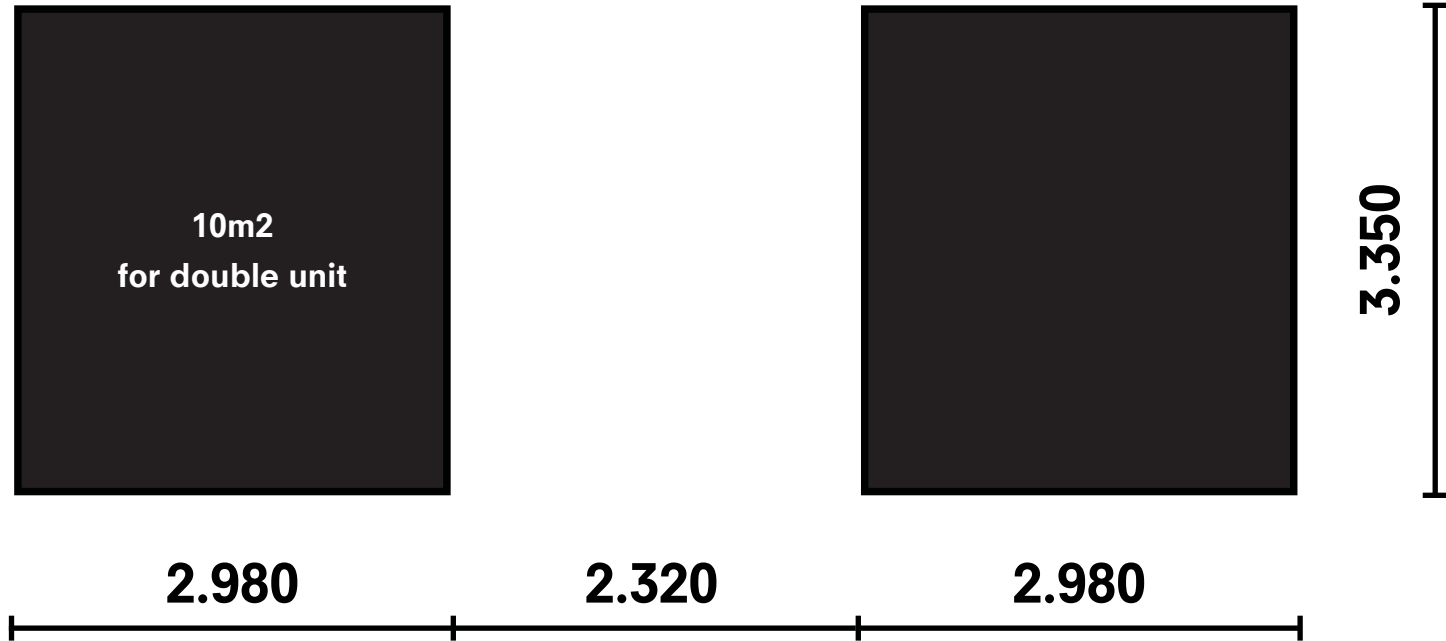

# BAGGAGE



# AUTOMATED BAGGAGE HANDLING

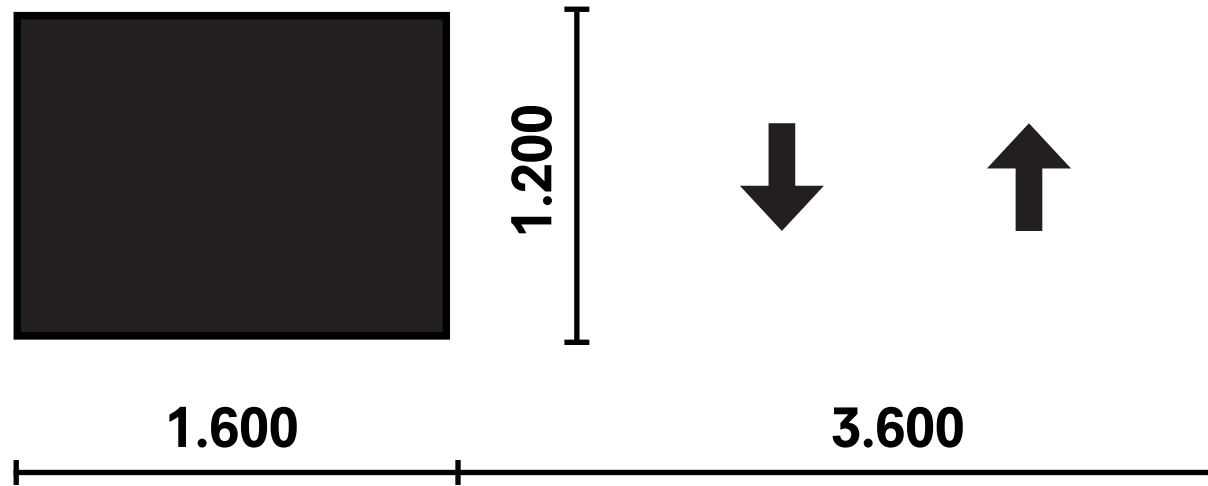

PROGRAM DESIGN BRIEF  
**SECURITY & CHECK-IN**

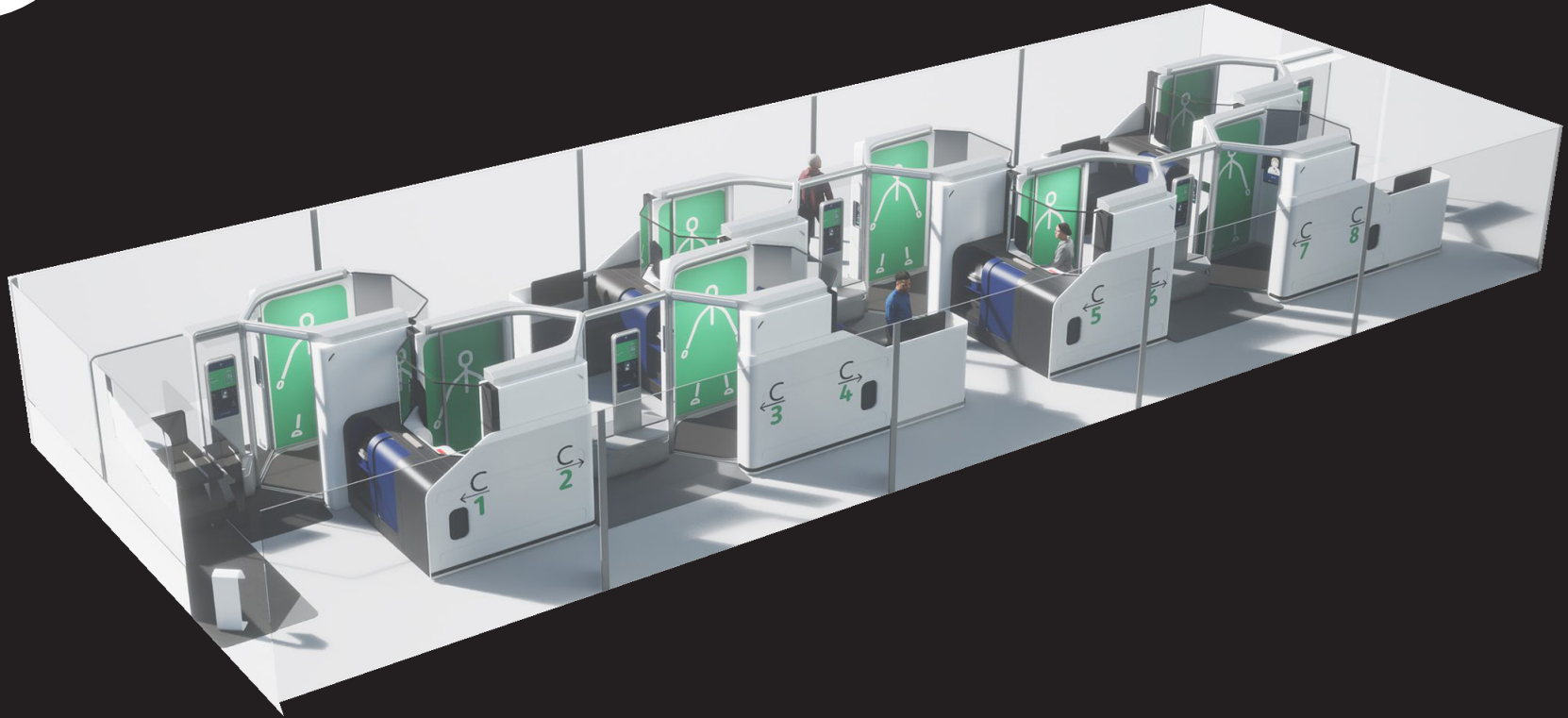

PROGRAM DESIGN BRIEF  
**SECURITY & CHECK-IN**

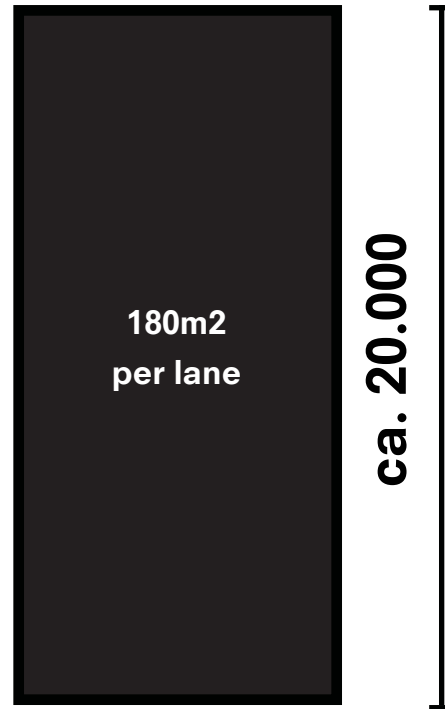
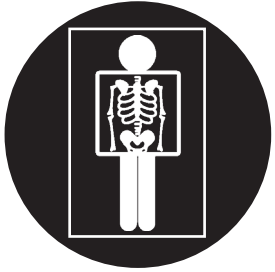

180m<sup>2</sup>  
per lane

ca. 20.000

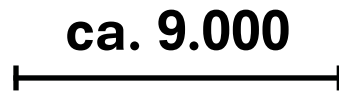

ca. 9.000

Traditional  
11:20 minutes

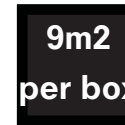

9m<sup>2</sup>  
per box

ca. 3.000

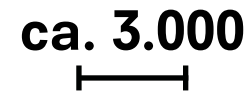

ca. 3.000

Micro-X  
1:00 minute

PROGRAM DESIGN BRIEF  
**RESERVE & COLLECT**



PROGRAM DESIGN BRIEF  
**RESERVE & COLLECT**



**RETAIL IS ON AVERAGE 30,2%  
OF AIRPORTS INCOME**





# TRADITIONAL PASSANGER JOURNEY



Arrival At Airport



Check - In &  
Luggage drop off



Security



Dwell Time



Boarding



Departure



Arrival



Luggage Claim

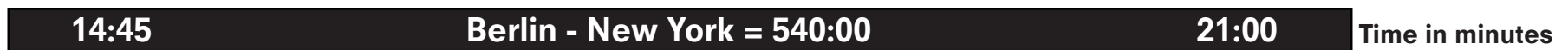

PROGRAM DESIGN BRIEF

# SUPERSONIC PASSENGER JOURNEY



Arrival At Airport



Luggage drop off



Security &  
Check - In



Dwell Time



Boarding



Departure



Arrival



Luggage Claim

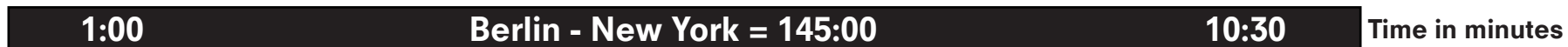

PROGRAM DESIGN BRIEF

# SUPERSONIC PASSENGER JOURNEY





# PROGRAM DESIGN BRIEF

## SUPERSONIC PROGRAM

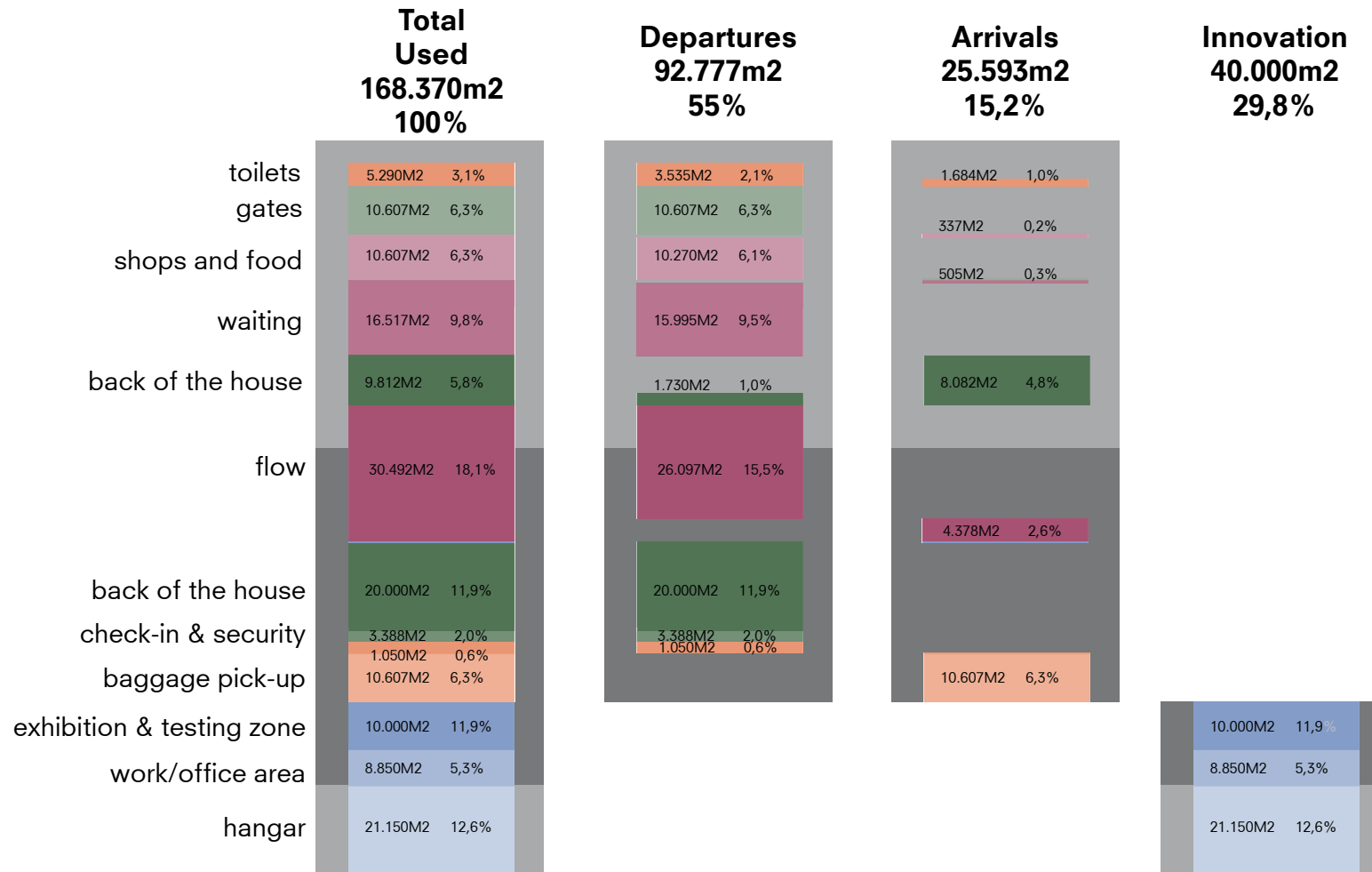

LANDSIDE AIRSIDE

# LANDSIDE - TERMINAL - AIRSIDE

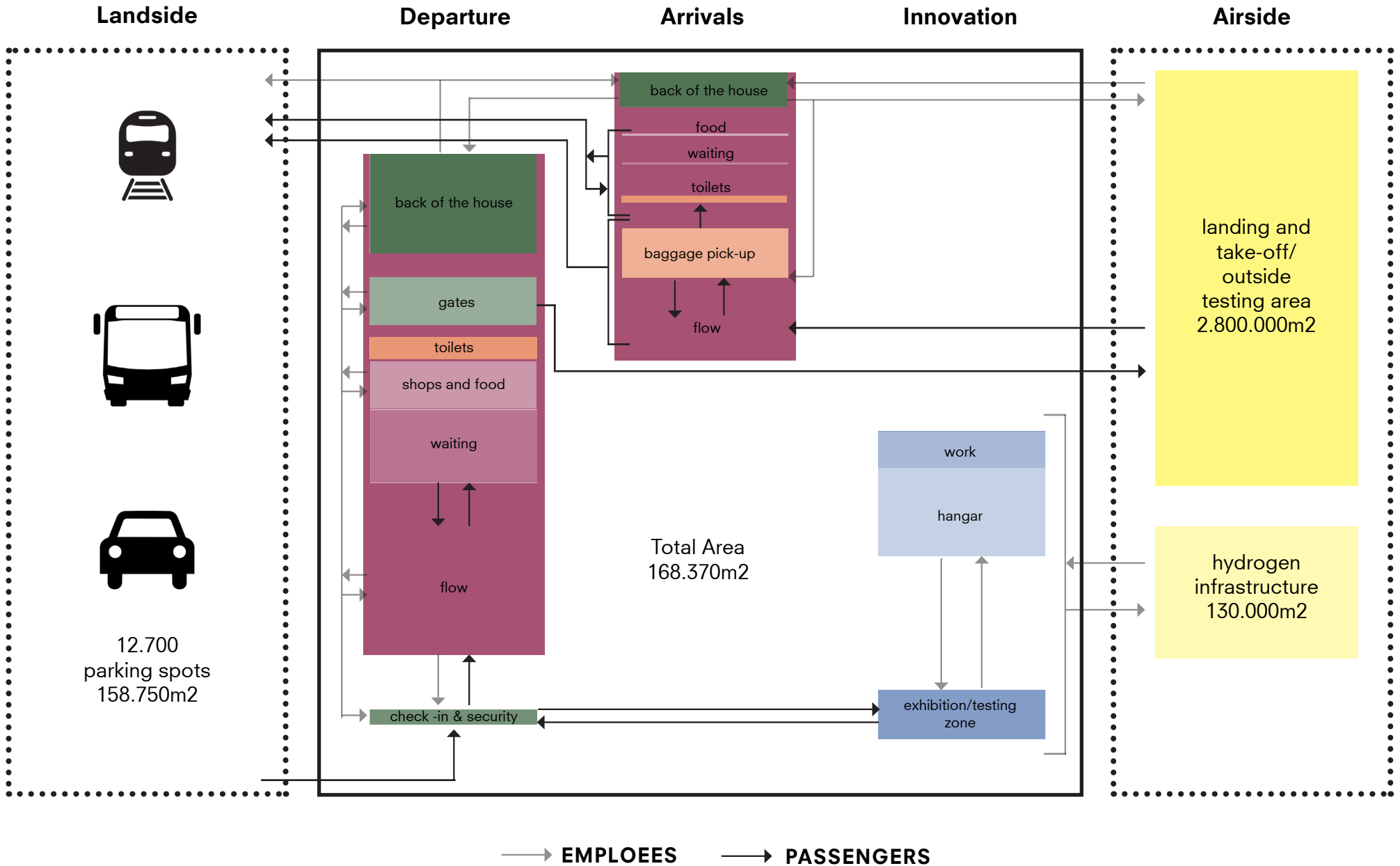

**WHERE TO FIT  
A PROGRAM OF  
3.260.000M<sup>2</sup> ?**

# SITE RESEARCH ENERGY

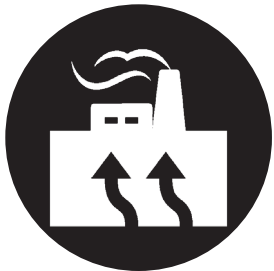
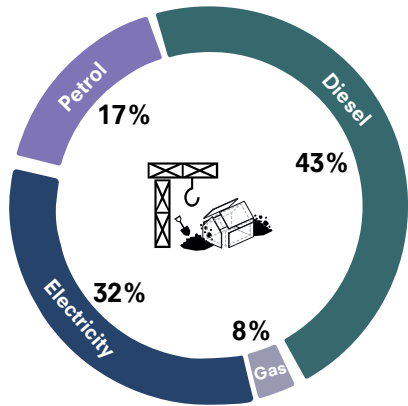

**Retrofit: Build on existing potentials**

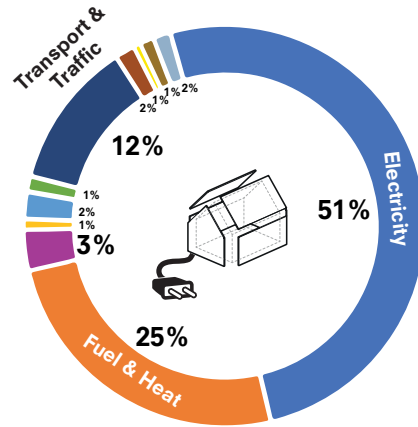

**Build on geothermal energy potentials**

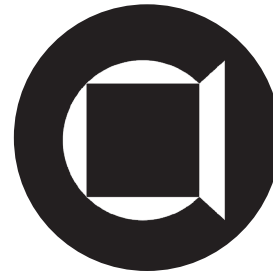
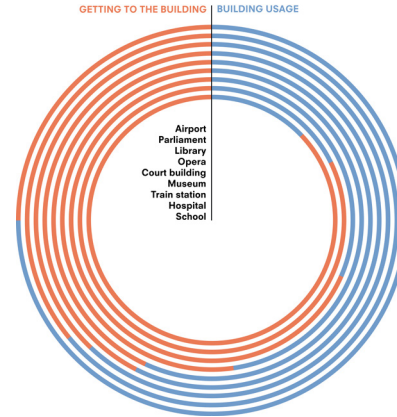

**Build with the aim to provide energy-efficient mobility**

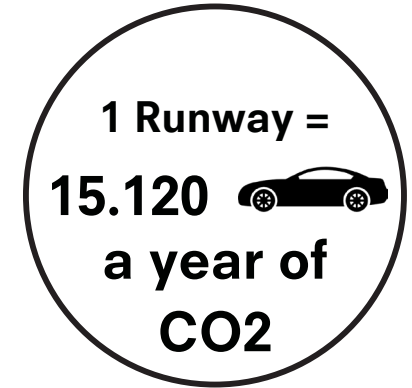

**Minimal additions to infrastructure**



# SITE RESEARCH AREA

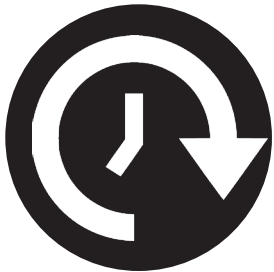
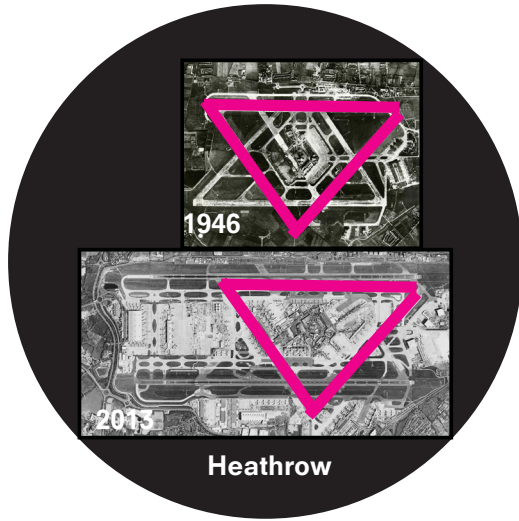

Enough space for  
now and future

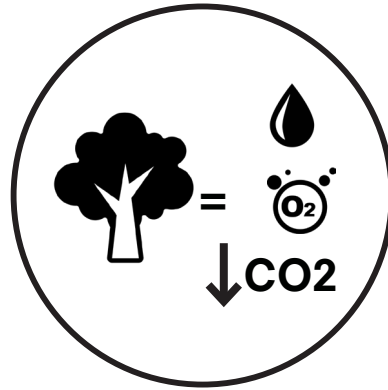

Not on nature rich  
area

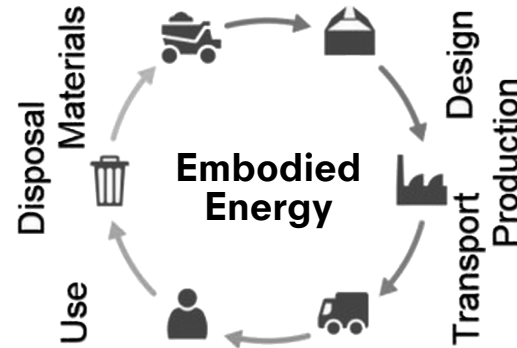

Low density area

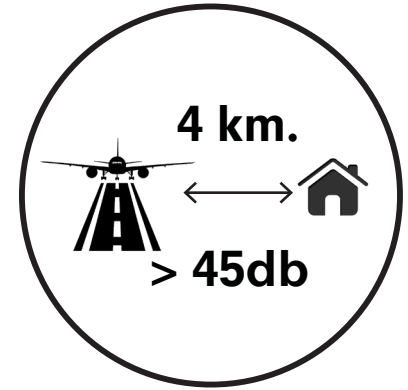

Safe noise area

# SITE RESEARCH BUILDING

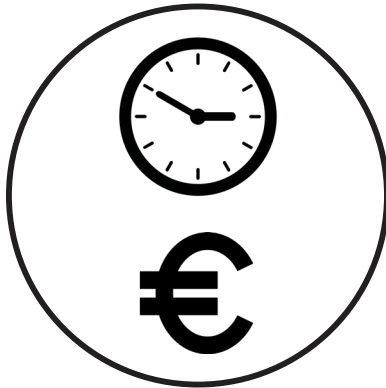
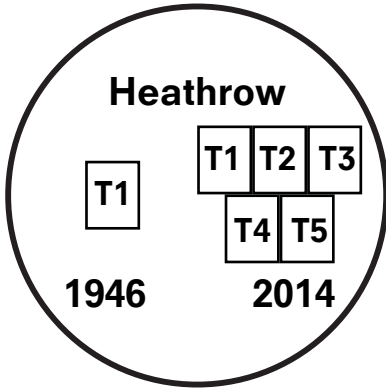
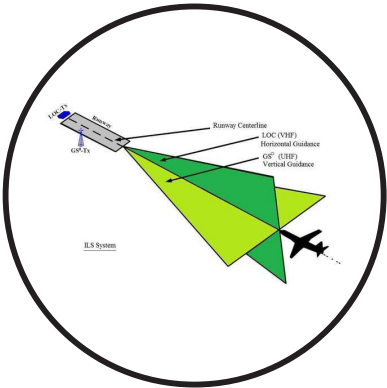
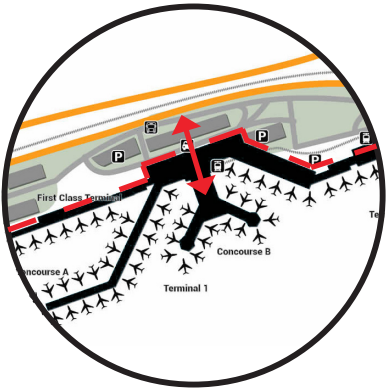

**Connection to air  
and landside**



**No negative effect  
on airplane motions**

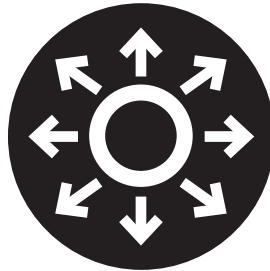

**Position with possibility  
to expand**

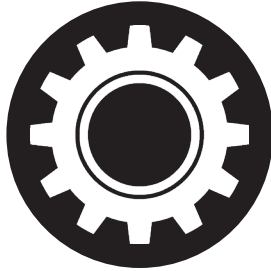

**Existing buildings need  
to function during  
construction**

# SITE REQUIREMENTS

## Energy



Accessible By Mobile Vehicles

## Area

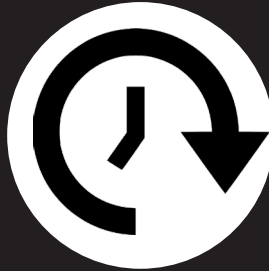

Enough Space For Now And Future

## Building



Connection To Air And Landside

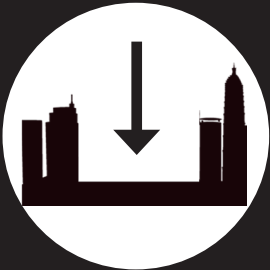

Retrofit - On Bare Land



Not On Nature Rich Area



No Negative Effect On Airplanes Motions



On Geothermal Potential

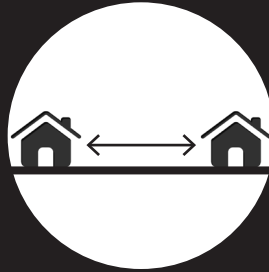

Low Density Area

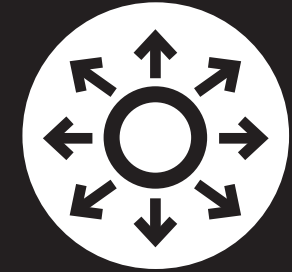

Position With Possibility To Expand



Minimal Additions To Infrastructure



Safe Noise Distance

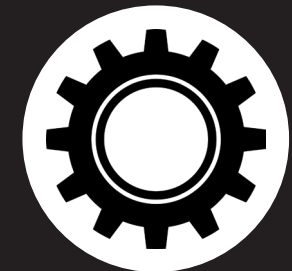

Existing Buildings Need To Function During Construction

# SITE OPTIONS

## Option 1

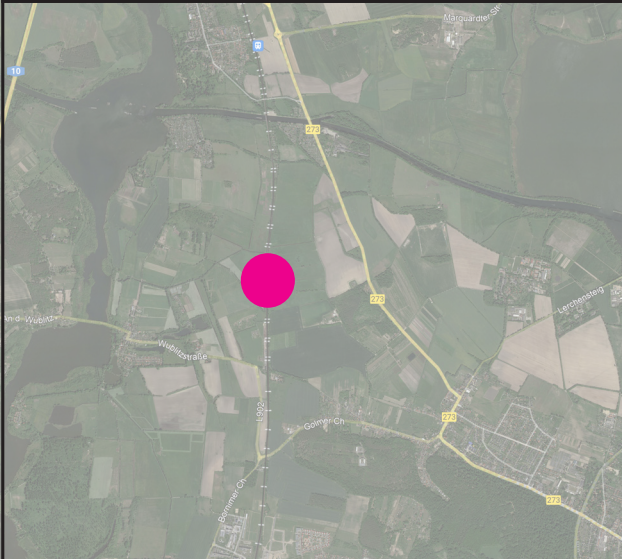

## Option 2

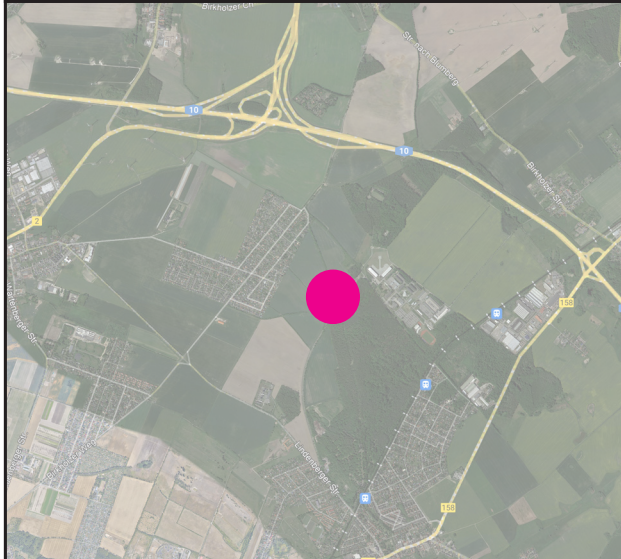

## Option 3

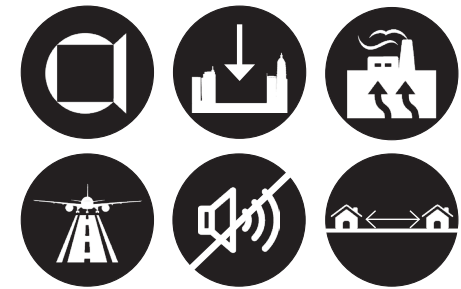
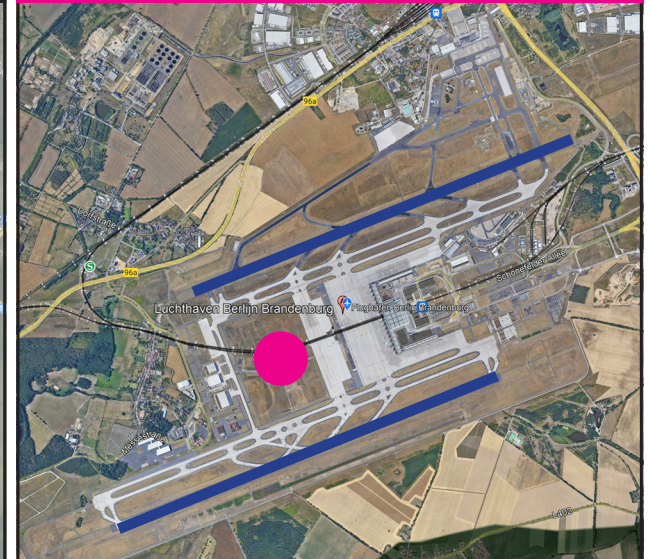

● Worldport    
 — Existing runways

# SITE M-SIZE REQUIREMENTS

Energy



Accessible By Mobile Vehicles

Area

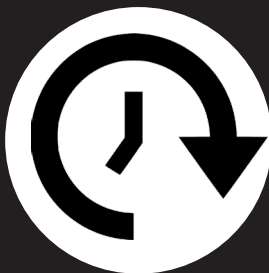

Enough Space For Now And Future

Building



Connection To Air And Landside



Retrofit - On Bare Land



Not On Nature Rich Area



No Negative Effect On Airplanes Motions



On Geothermal Potential



Low Density Area

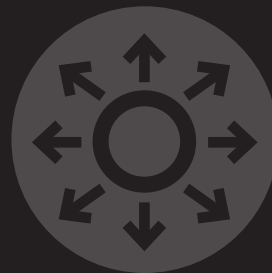

Position With Possibility To Expand



Minimal Additions To Infrastructure



Safe Noise Distance



Existing Buildings Need To Function  
During Construction

# SITE M-SIZE



roads airplanes infra parking bare land agriculture nature existing airport buildings

complex projects

SITE M SIZE  
**ACCESSIBILITY**

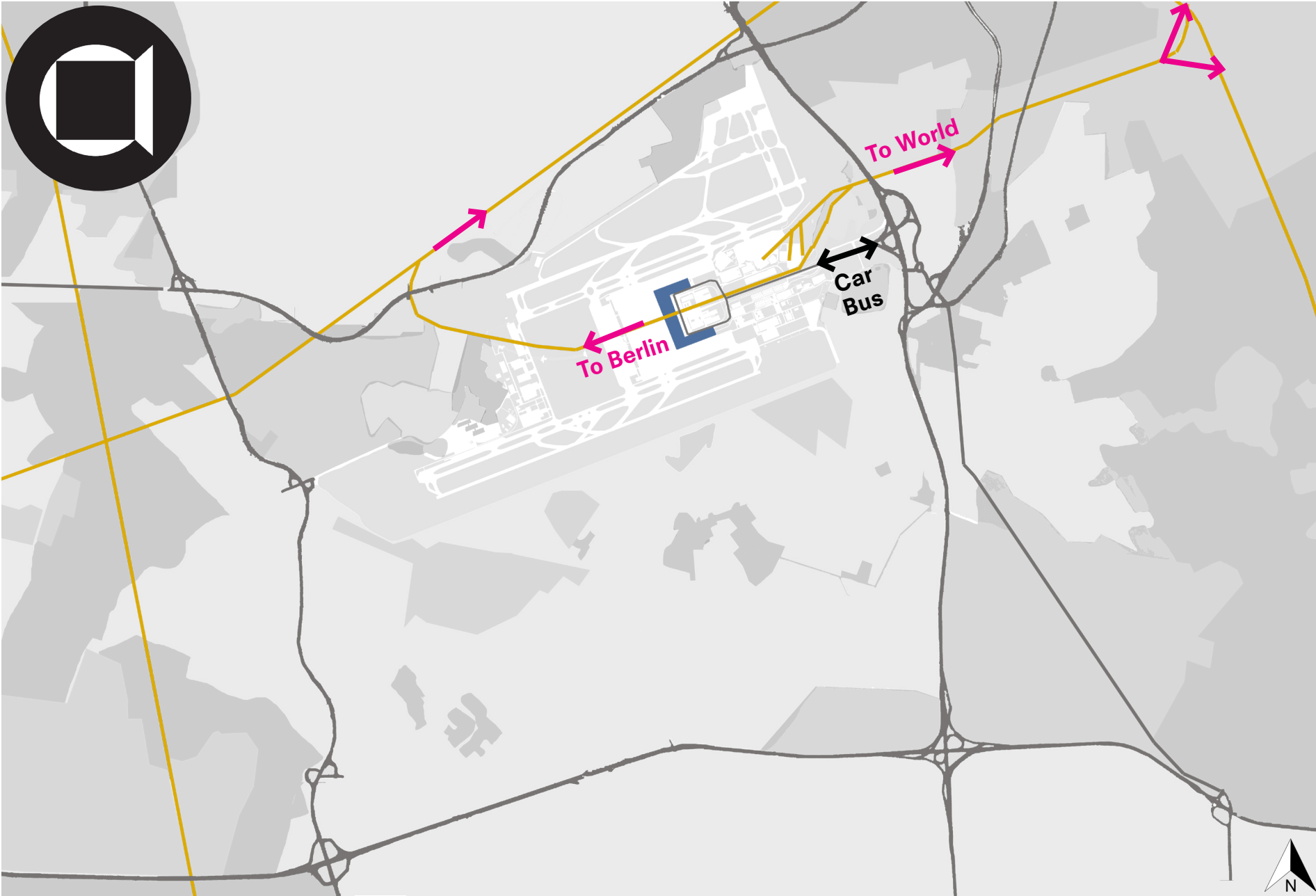

 existing airport  railway  roads

SITE M SIZE  
**RETROFIT ON BARE LAND**

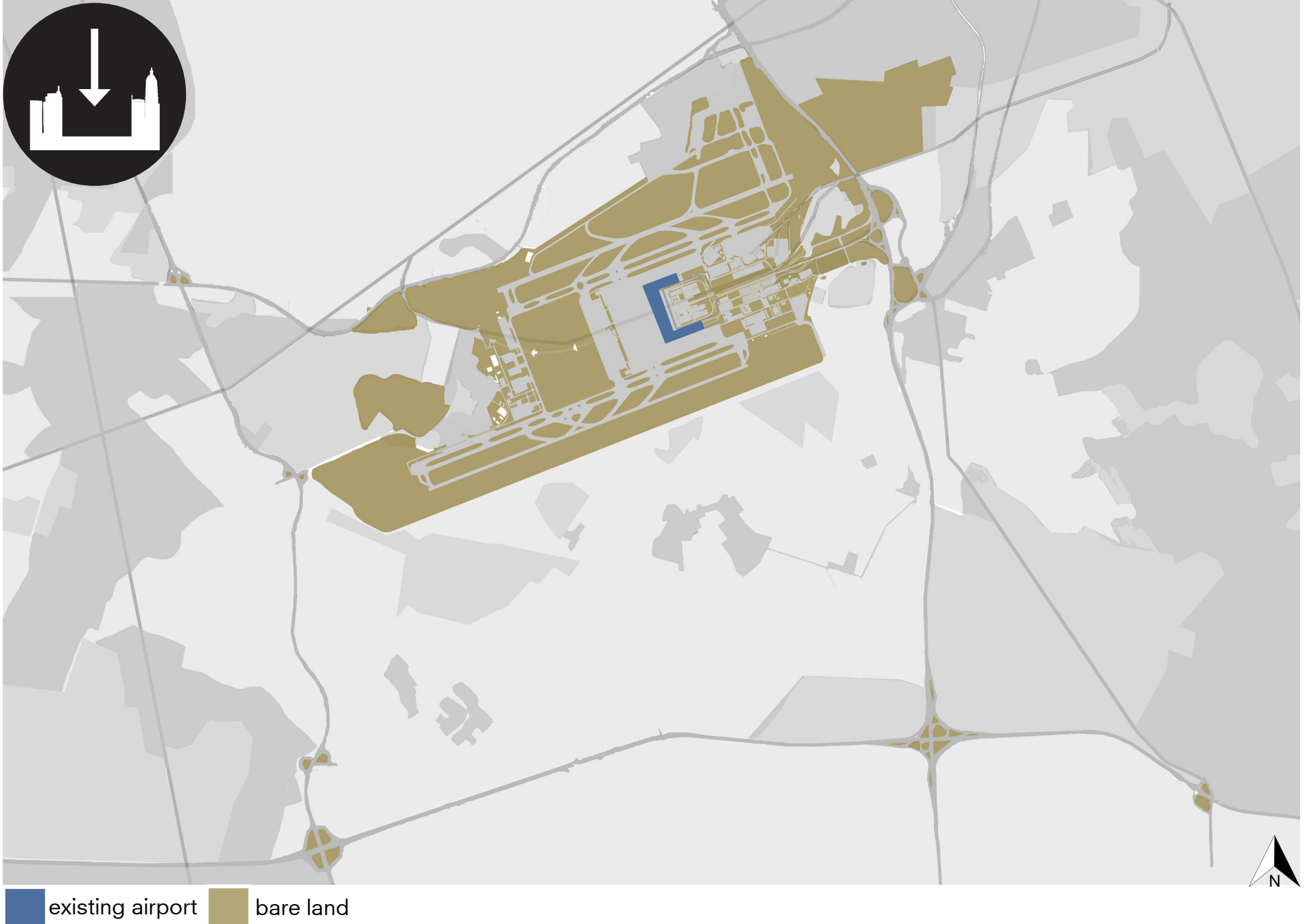

existing airport    bare land



SITE M SIZE

# MINIMAL ADDITIONS TO INFRASTRUCTURE

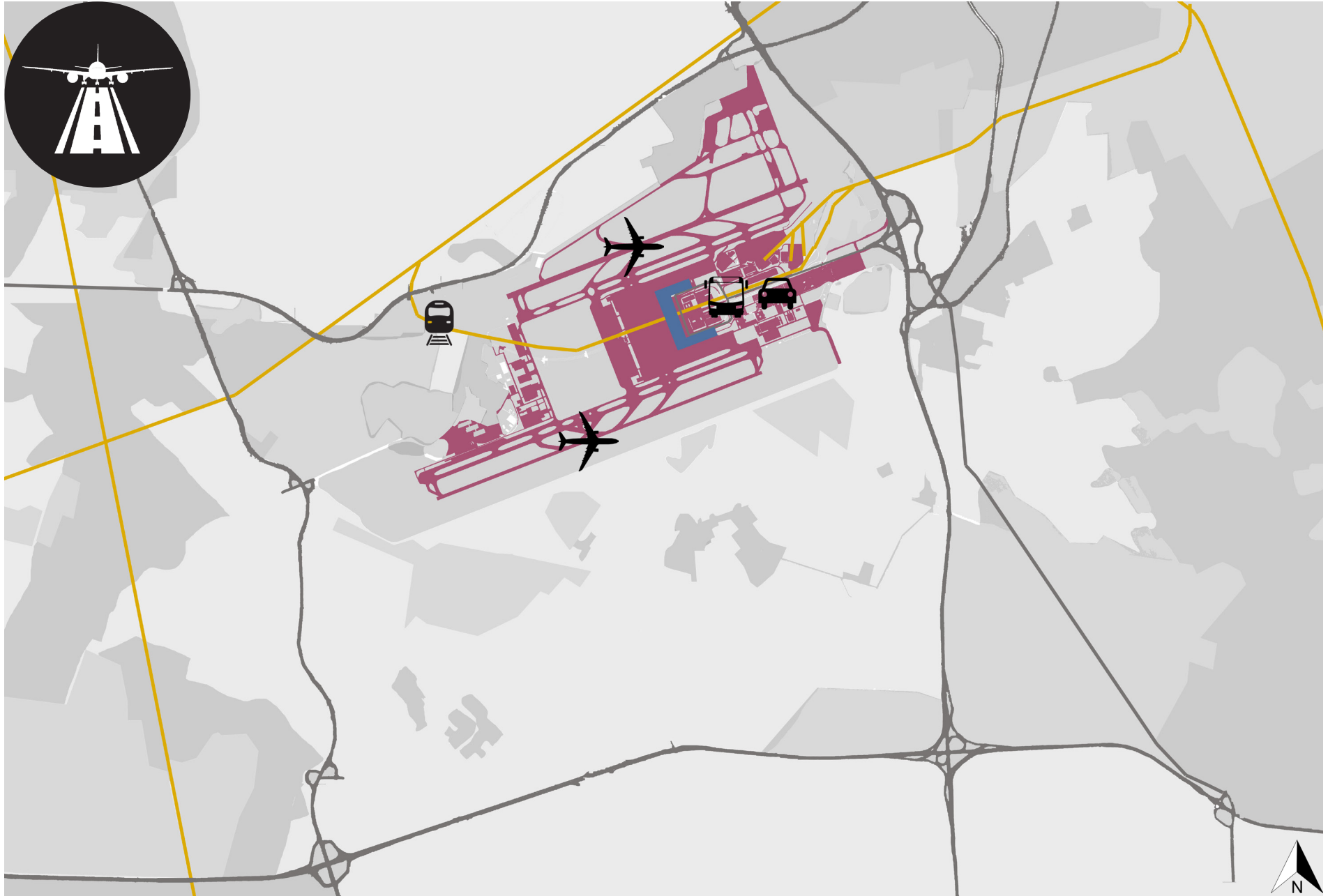

# ENOUGH SPACE FOR NOW AND FUTURE

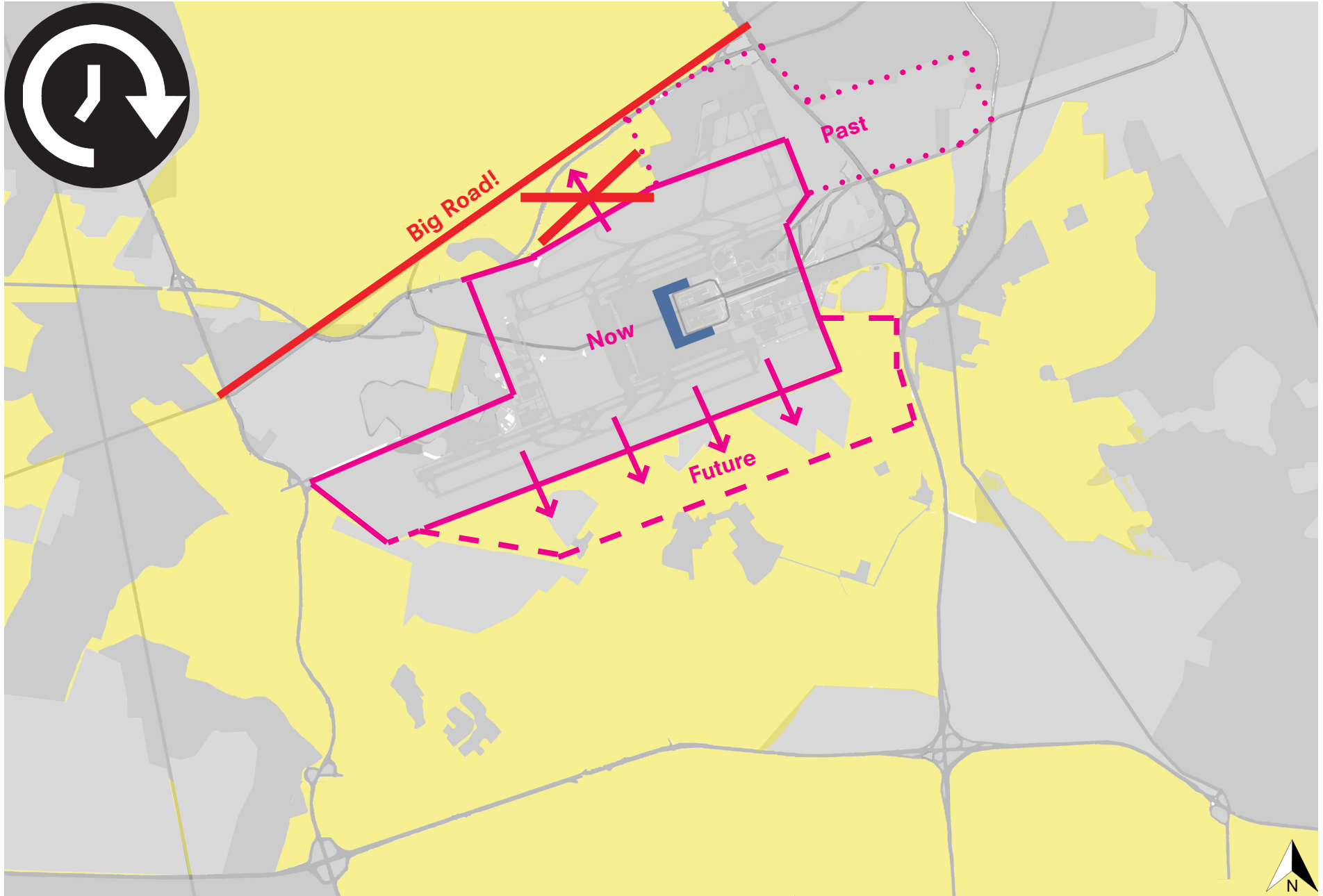

existing airport    agriculture    direction of growth    not possible

SITE M SIZE  
**NOT ON NATURE**

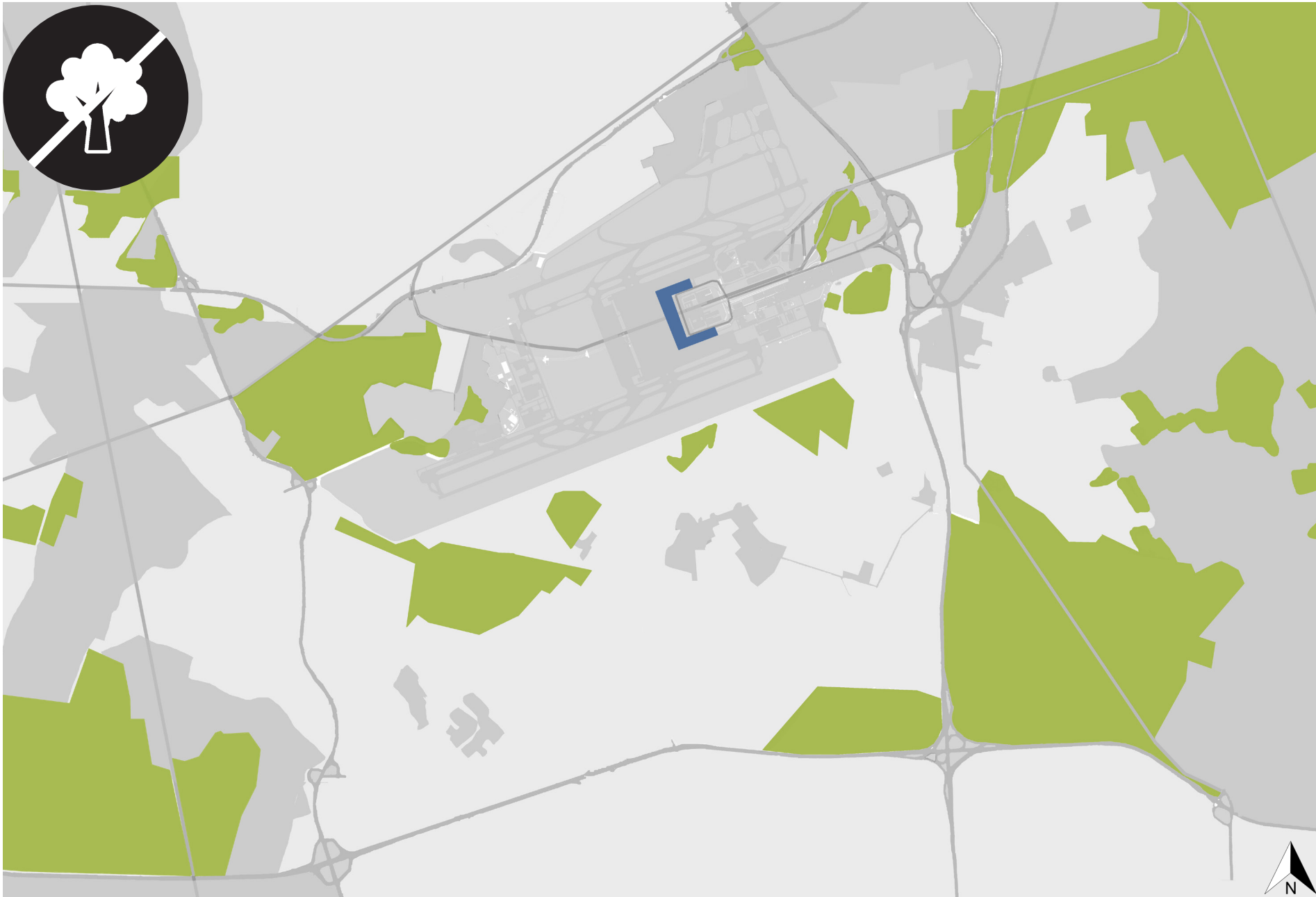

existing airport nature

SITE M SIZE  
**NOT ON NATURE**



existing airport nature

SITE RESEARCH  
**NEEDED ELEMENTS**



**Terminal Building**

**118.370m<sup>2</sup>**

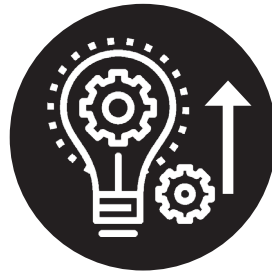

**Innovation Centre**

**40.000m<sup>2</sup>**

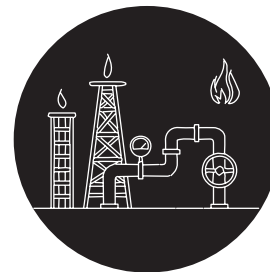

**Geothermal Energy**

**82.000m<sup>2</sup>**



**Hydrogen Fuel**

**130.000m<sup>2</sup>**

SITE M SIZE

# AREA FOR THE INNOVATION CENTRE



— — — potential area for positioning the Innovation Centre

# SITE M SIZE

## AREA FOR ENERGY PRODUCTION



— — — potential area for positioning energy production

SITE M SIZE

# AREA FOR SUPERSONIC WORLDPORT



— — — potential area for positioning Supersonic Worldport



SITE  
**S-SIZE REQUIREMENTS**

**Energy**



**Accessible By Mobile Vehicles**

**Area**



**Enough Space For Now And Future**

**Building**



**Connection To Air And Landside**

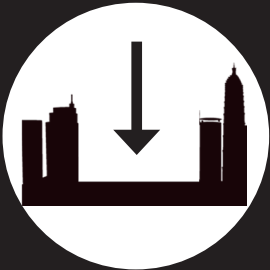

**Retrofit - On Bare Land**



**Not On Nature Rich Area**



**No Negative Effect On Airplanes Motions**



**On Geothermal Potential**



**Low Density Area**

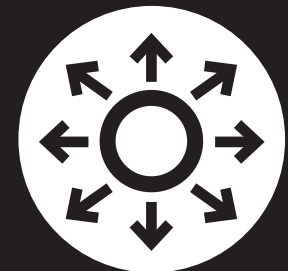

**Position With Possibility To Expand**



**Minimal Additions To Infrastructure**



**Safe Noise Distance**

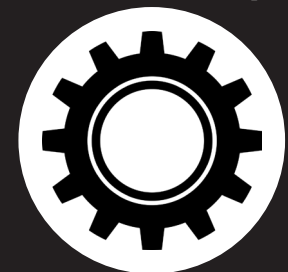

**Existing Buildings Need To Function  
During Construction**

# SITE S-SIZE

-  potential area for positioning Supersonic Worldport
-  roads
-  airplanes infra
-  parking
-  bare land
-  agriculture
-  nature
-  existing airport
-  buildings
-  express busses
-  access to S-Bahn
-  2 runways 4000 length
-  10.000 parking spots

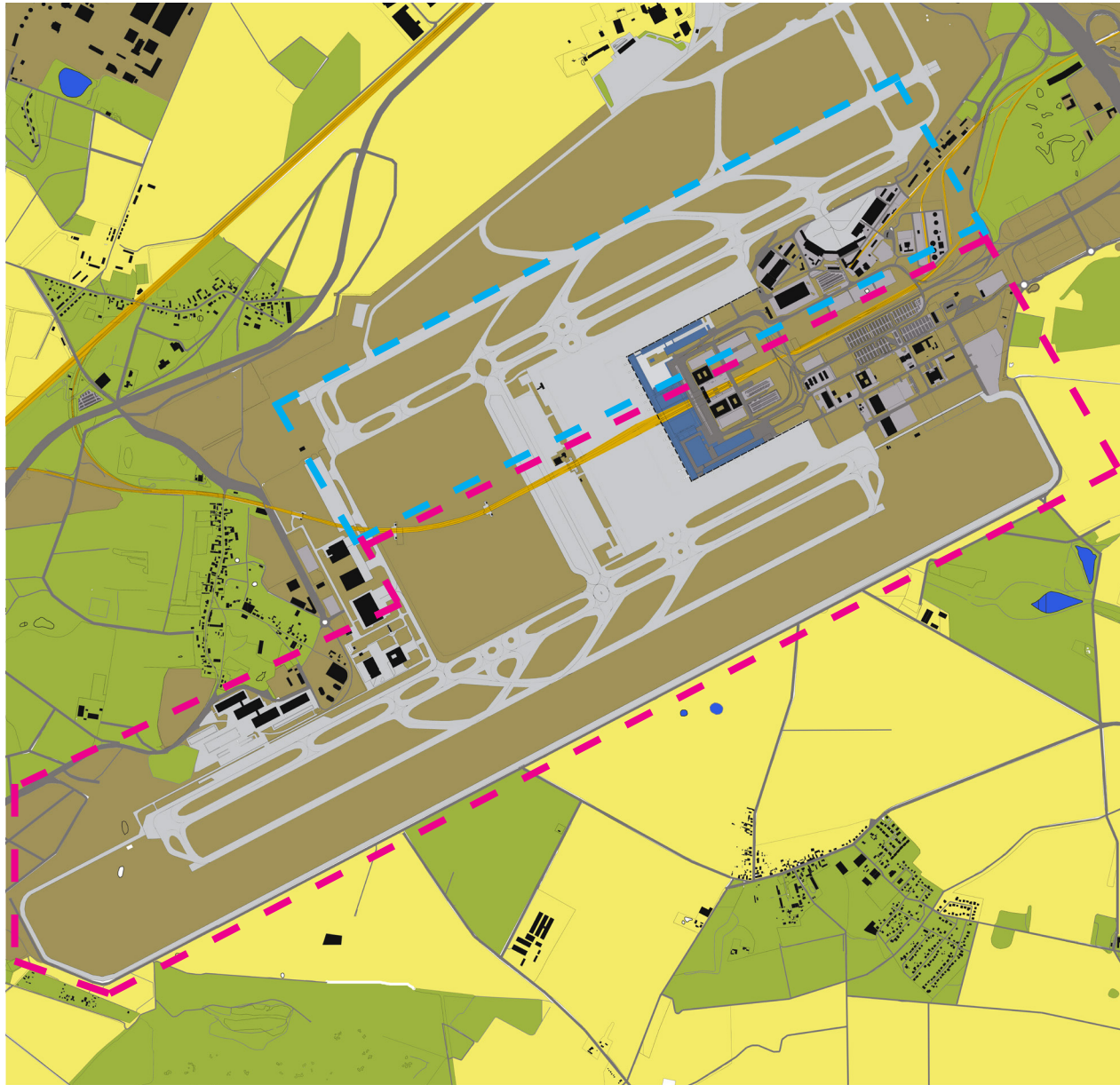

# SITE S SIZE ACCESSIBILITY





-  drive direction
-  existing airport
-  railway
-  roads
-  parking

# SITE S SIZE

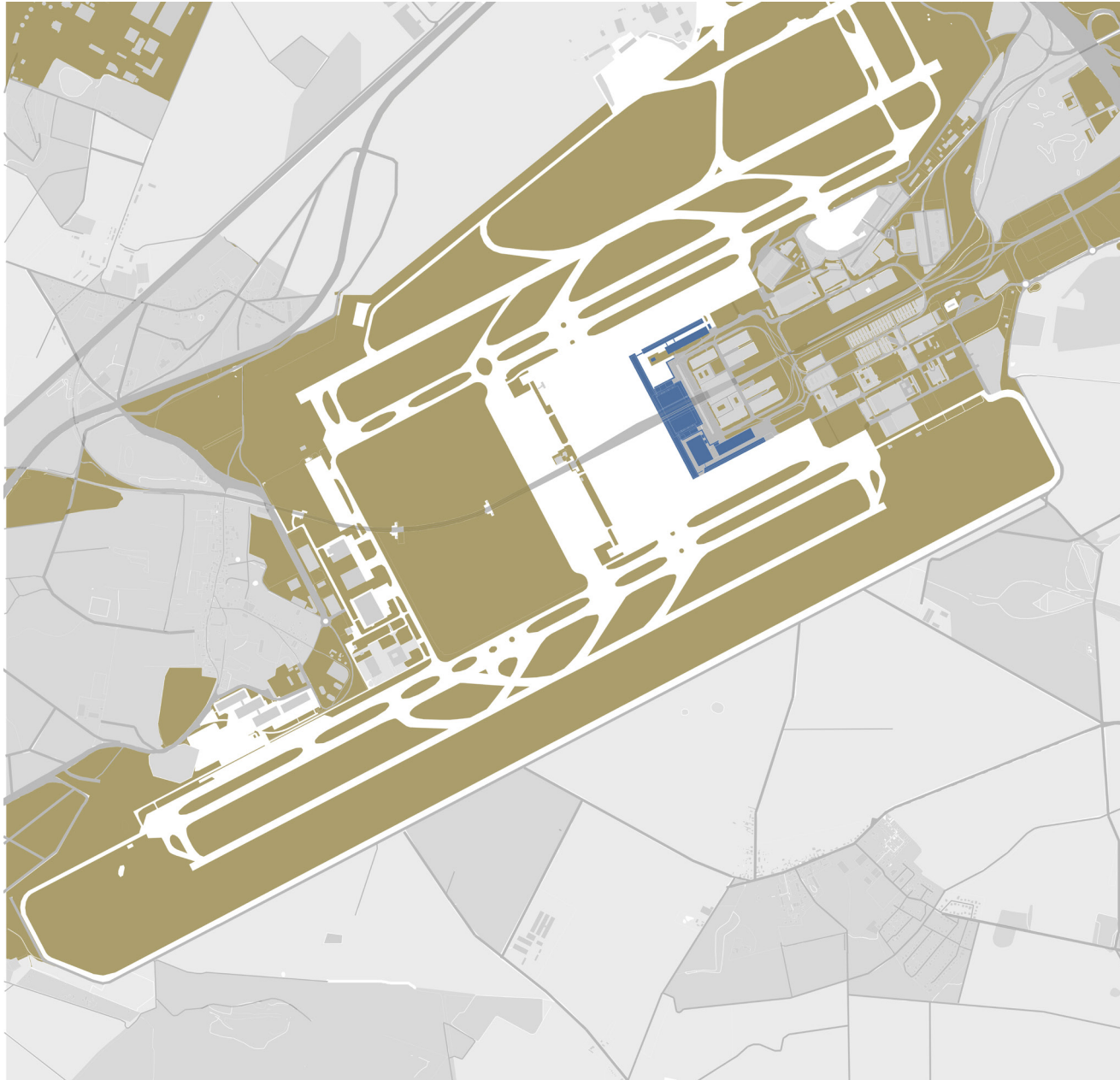
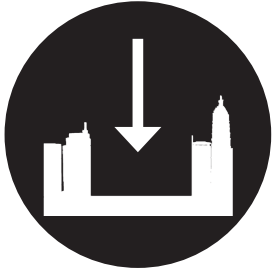
## RETROFIT ON BARE LAND



-  existing airport
-  bare land



# CONNECTION TO AIR AND LAND SIDE

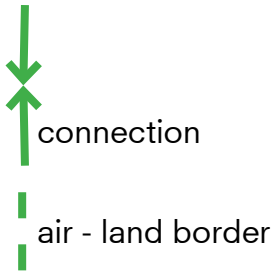

# NO NEGATIVE EFFECT ON AIRPLANES MOTIONS



↑ most common airplanes motions currently



# POSITION WITH POSSIBILITY TO EXPAND

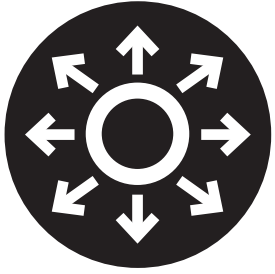



possible future  
runway

↑  
direction of  
expansion

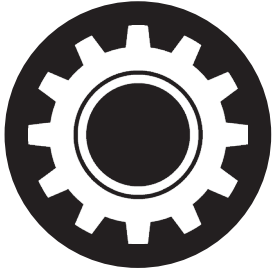

# EXISTING BUILDINGS DURING CONSTRUCTION



-  existing airport
-  buildings





DESIGN BRIEF - SITE  
**POSITIONING**



**Terminal Building**

**118.370m<sup>2</sup>**



DESIGN BRIEF - SITE  
**POSITIONING**

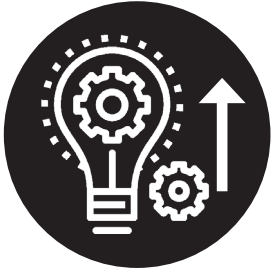

**Innovation Centre**

**50.000m<sup>2</sup>**



DESIGN BRIEF - SITE  
**POSITIONING**



**Geothermal Energy**

**82.000m<sup>2</sup>**

**3km<sup>2</sup>  
wells**



DESIGN BRIEF - SITE  
**POSITIONING**















Hydrogen Fuel

**130.000m<sup>2</sup>**



# 2030 - ROUTES

-  fuel & ground handling
-  fire department
-  supersonic airplane
-  bus stops
-  offices
-  train station
-  hotel
-  parking
-  car/bus route
-  potential Innovation Centre
-  potential Supersonic Worldport
-  BER airport

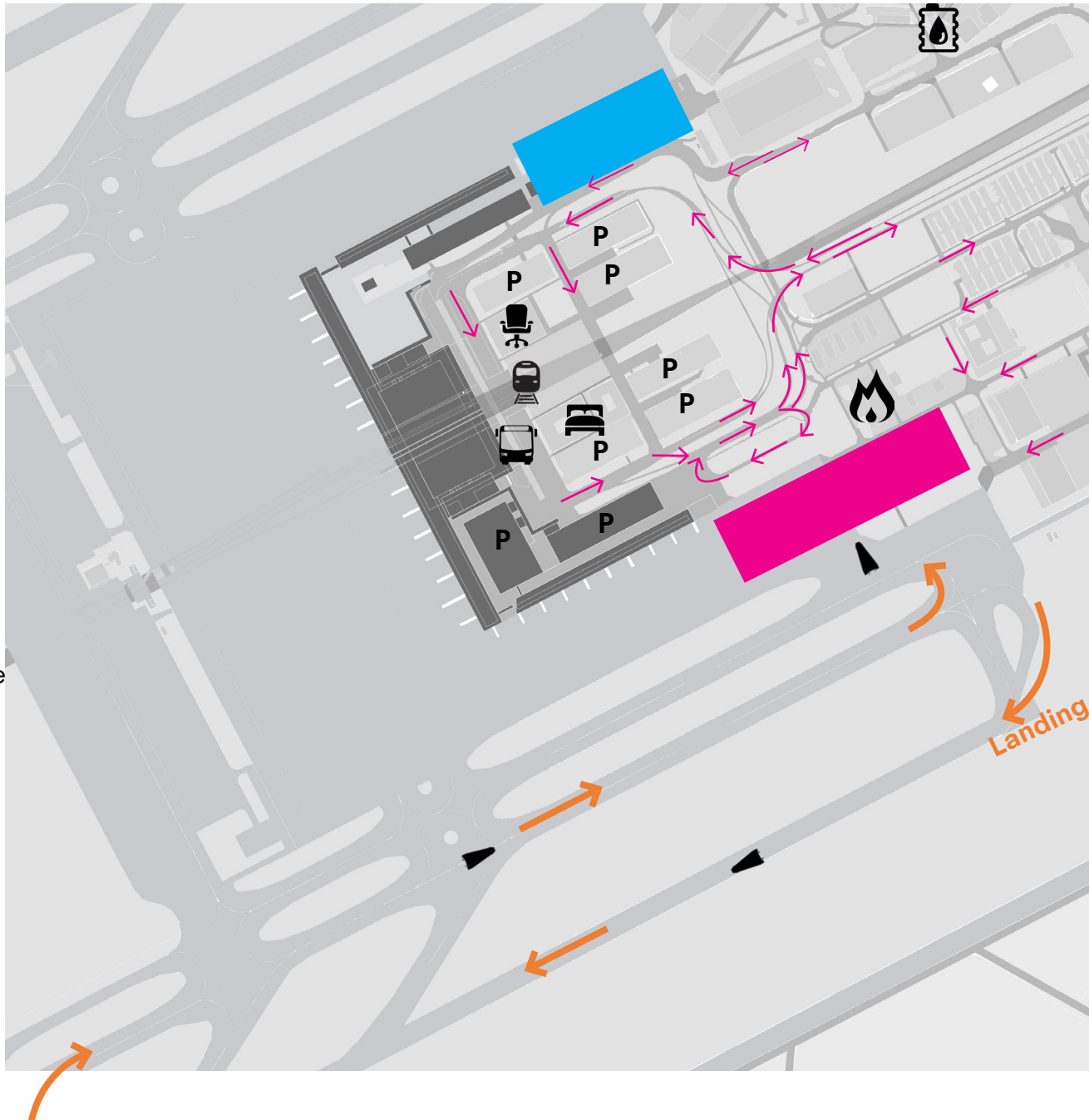

SITE DESIGN BRIEF

# CONNECTION EXISTING & NEW

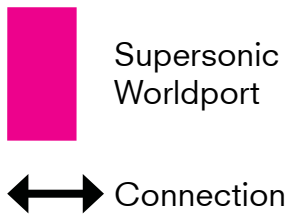
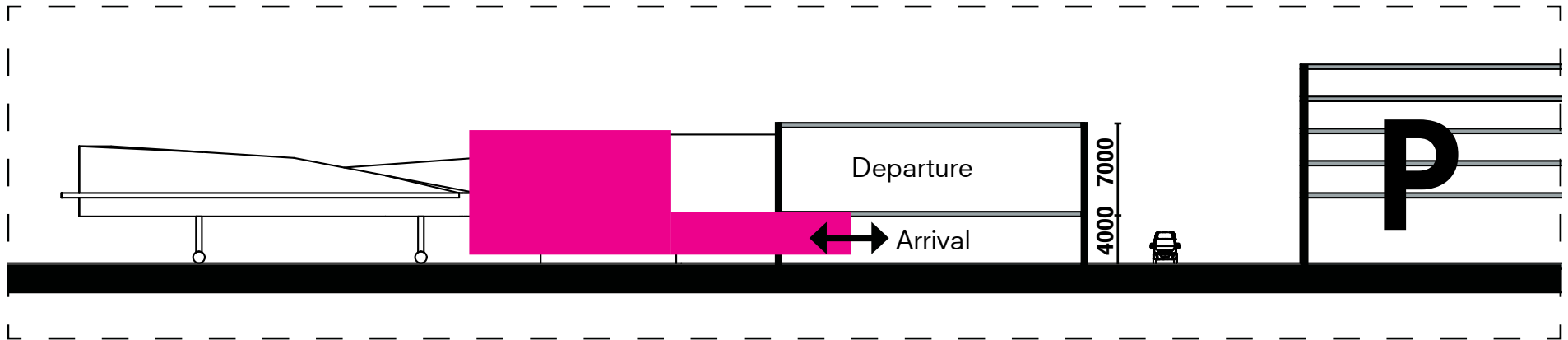

OVERVIEW

# PROJECT AMBITION



**Sustainable Development**

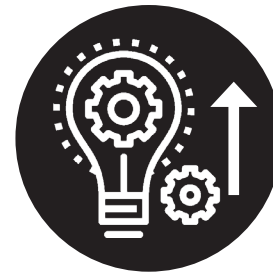

**Innovation Growth**



**Connecting The World**

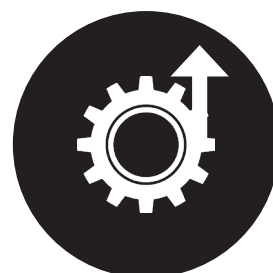

**Efficiency**

OVERVIEW  
**OVERVIEW CLIENT**

**50%**

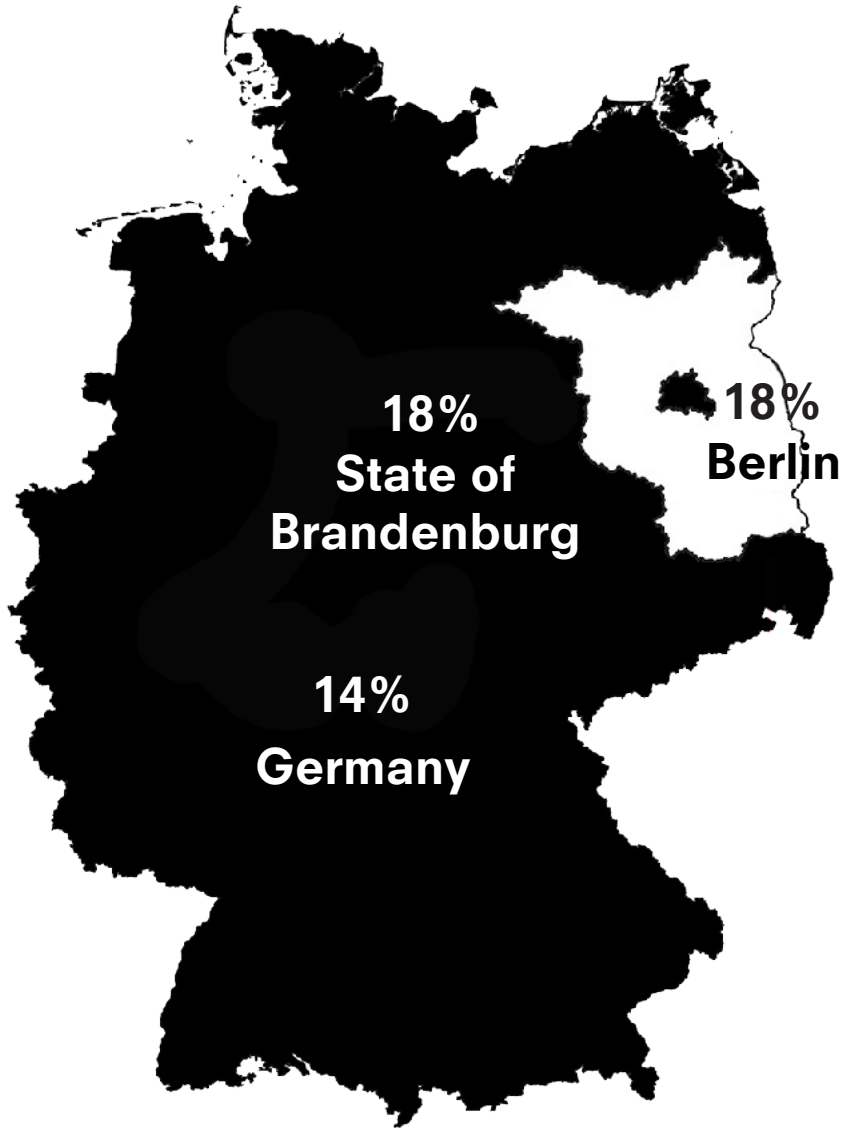

**50%**

 **Lufthansa** 15%

  
**Destinus.** 10%

**Hydrogen  
Airport** | 10%

**MICRO-X** 5%

**MATERNA  
IPS** intelligent  
passenger  
solutions 5%

  
**MORPHO DYS** 5%



# OVERVIEW PROGRAM

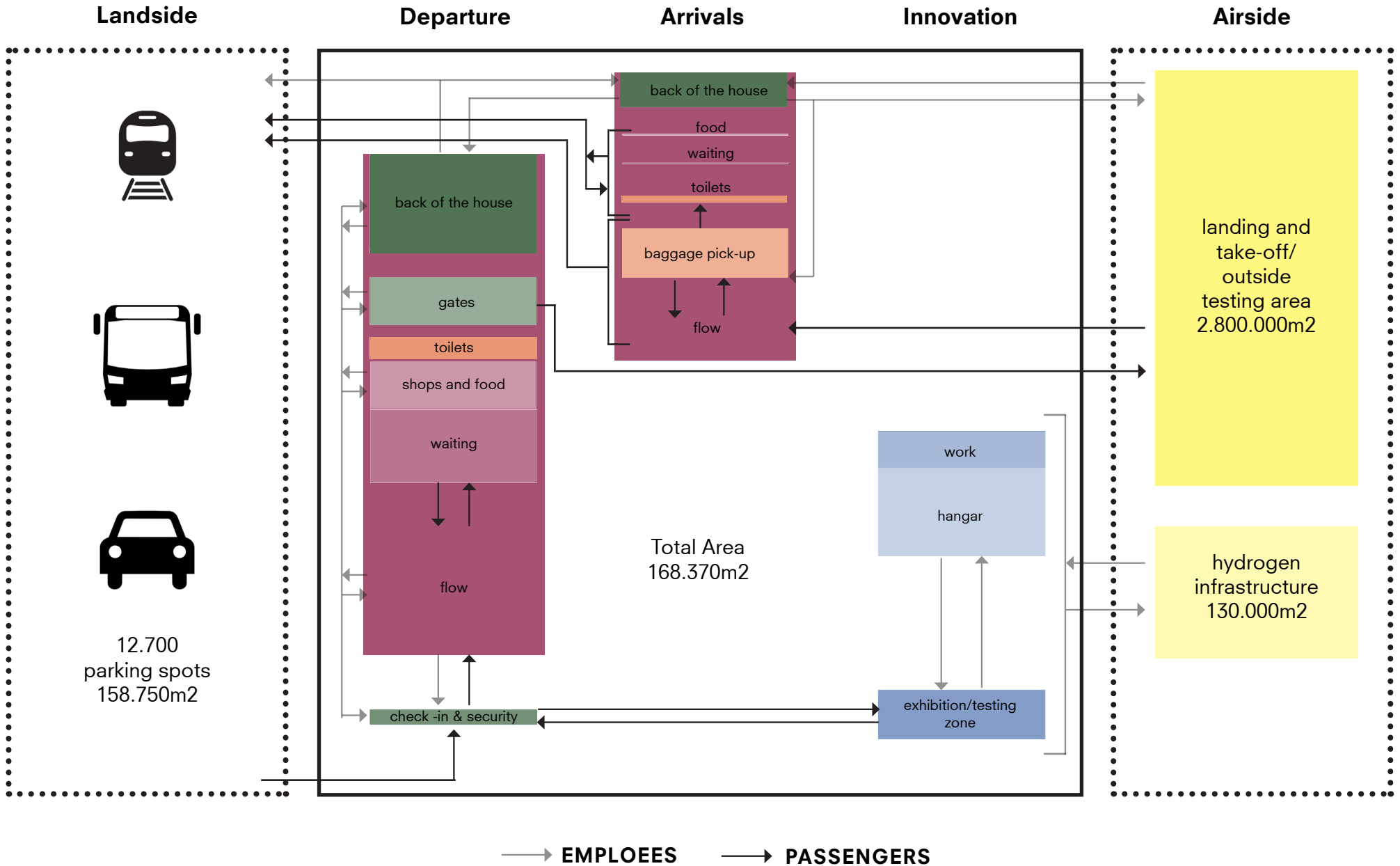

01 INTRODUCTION

02 RESEARCH

& DESIGN BRIEF

**03 CONCEPT**

04 IMPLEMENTATION

05 DEVELOPMENT

06 CONCLUSION

# CONCEPT OPTIONS

CLIENT

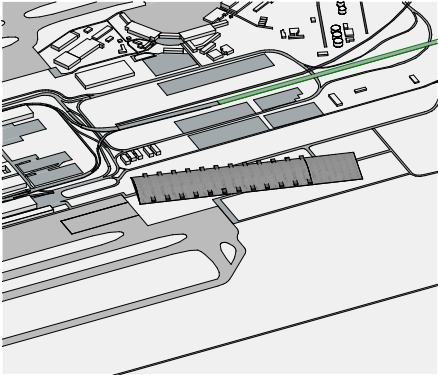

LANDMARK

PROGRAM

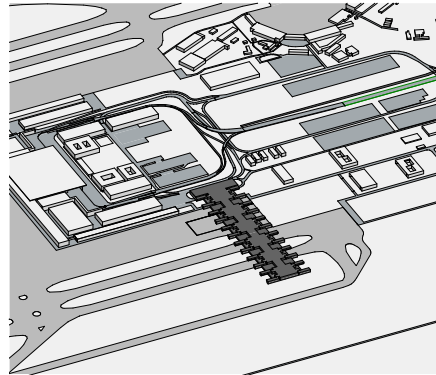

TRAIN  
STATION

SITE

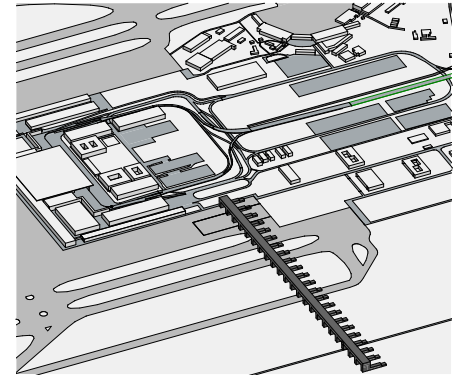

DRIVE  
THROUGH

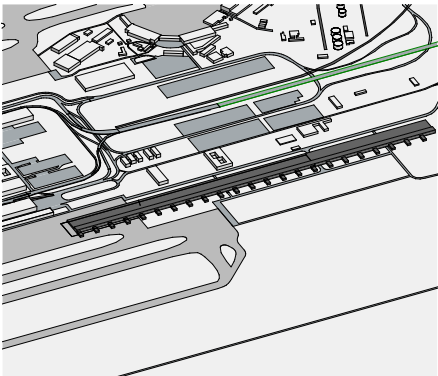

FUTURE  
RESISTANT

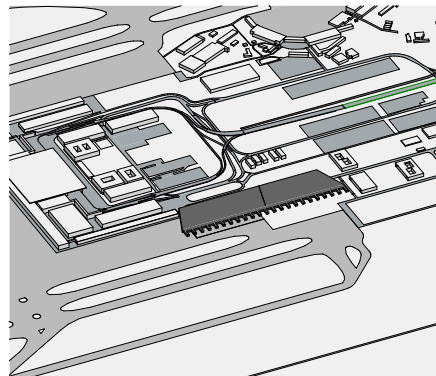

PASSANGER  
FOCUSED

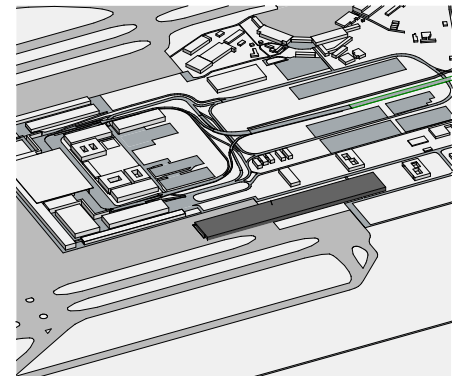

CONTEXT  
FIT

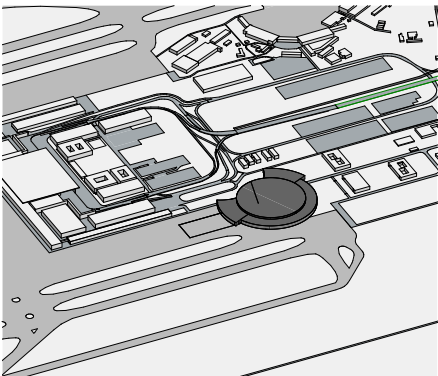

CENTRALIZED

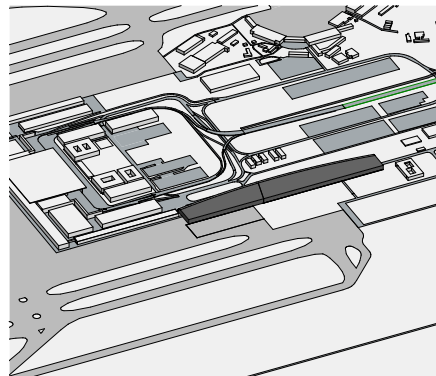

EFFICIENCY

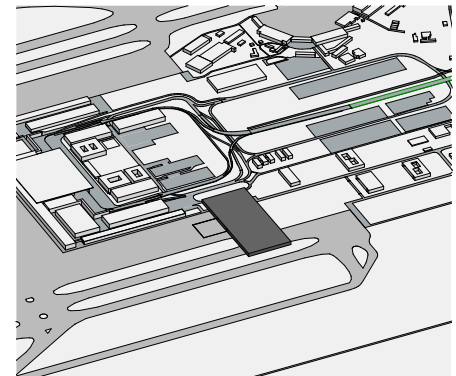

AIRPLANE  
PARKING

# CONCEPT CHOICES

CLIENT

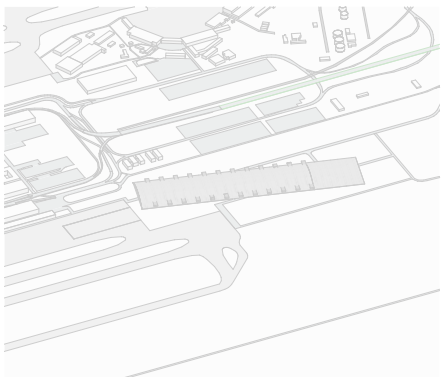

LANDMARK

PROGRAM

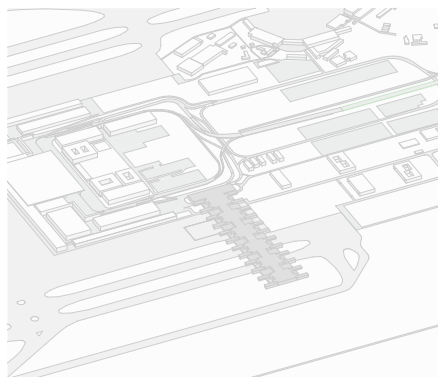

TRAIN  
STATION

SITE

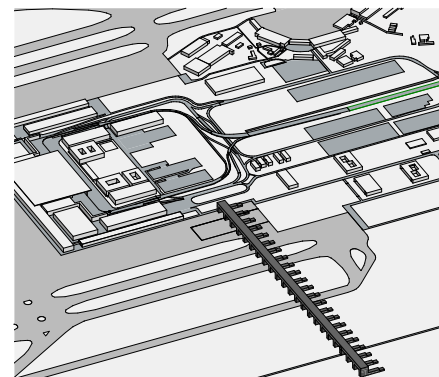

DRIVE  
THROUGH

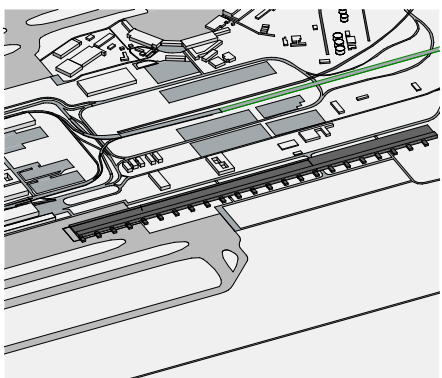

FUTURE  
RESISTANT

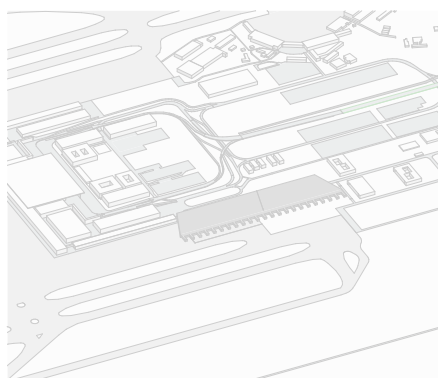

PASSANGER  
FOCUSED

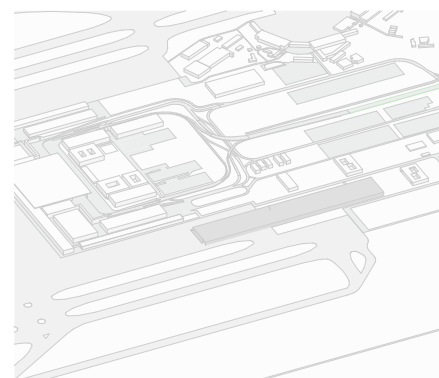

CONTEXT  
FIT

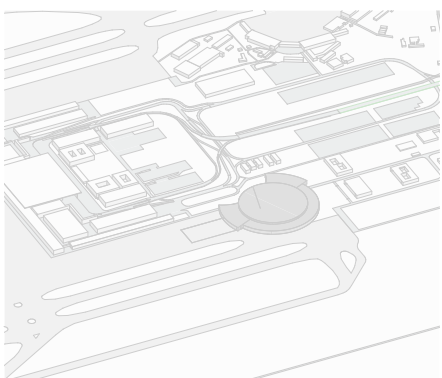

CENTRALIZED

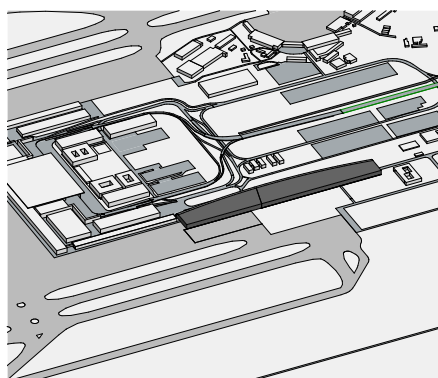

EFFICIENCY

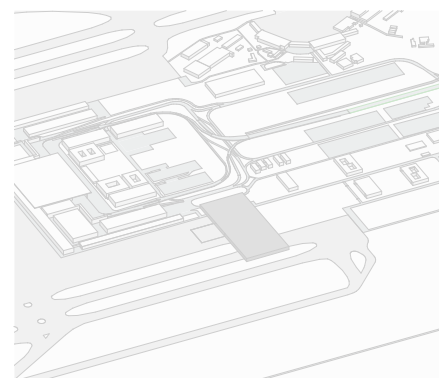

AIRPLANE  
PARKING

CONCEPT  
**CLIENT - FUTURE RESISTANT**

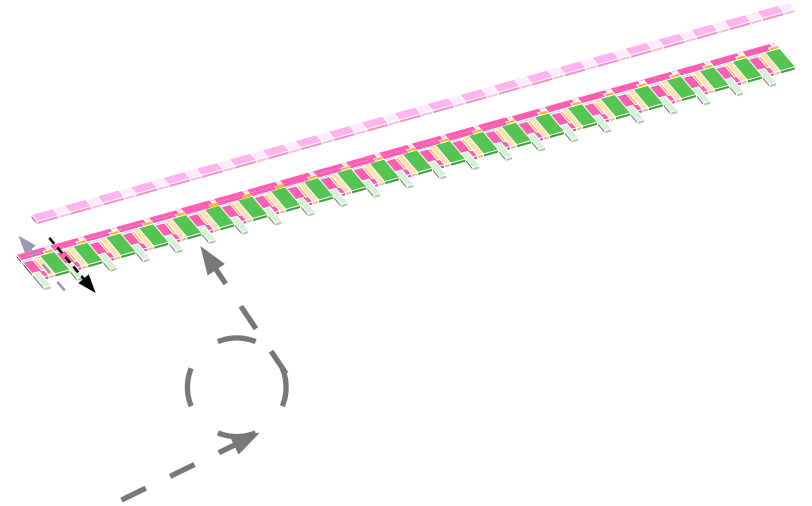
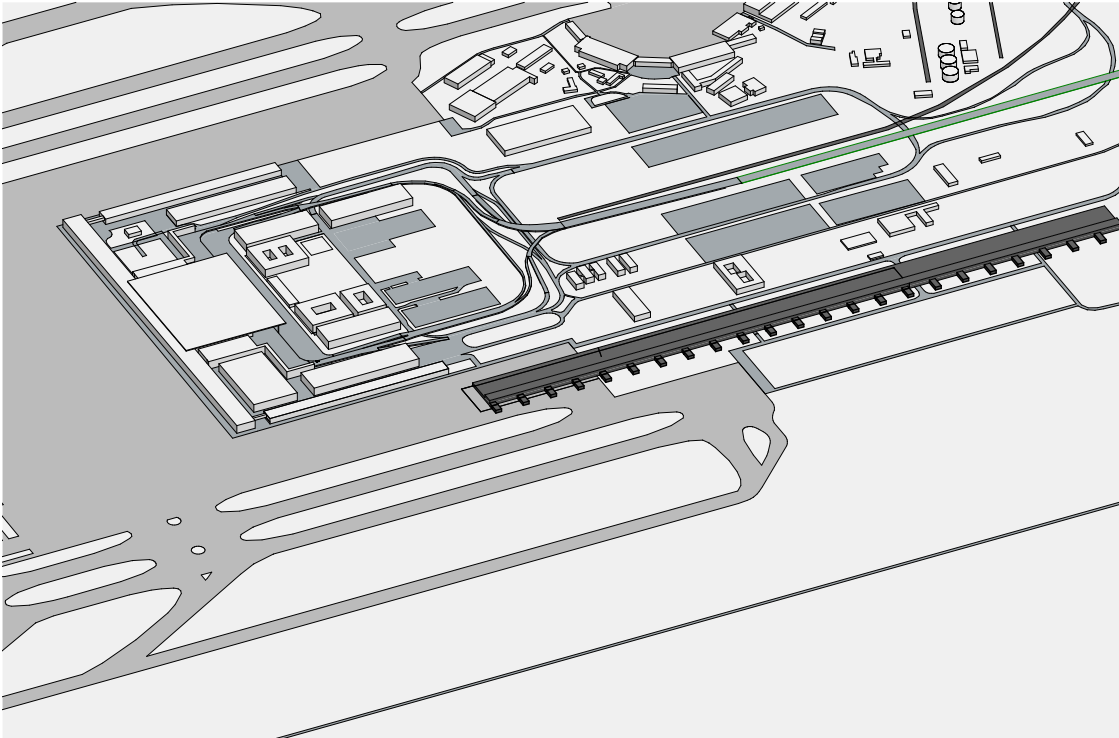

- departures ----->
- arrivals - - - - ->
- airplanes - - - - ->

# CONCEPT

## PROGRAM - EFFICIENCY

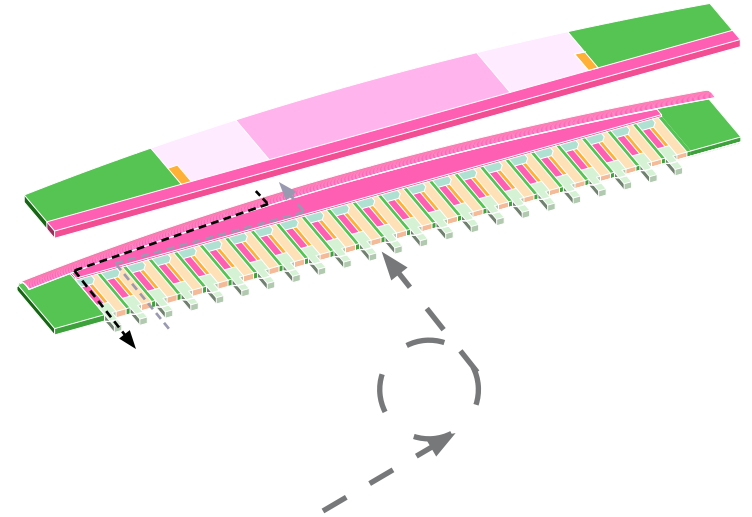
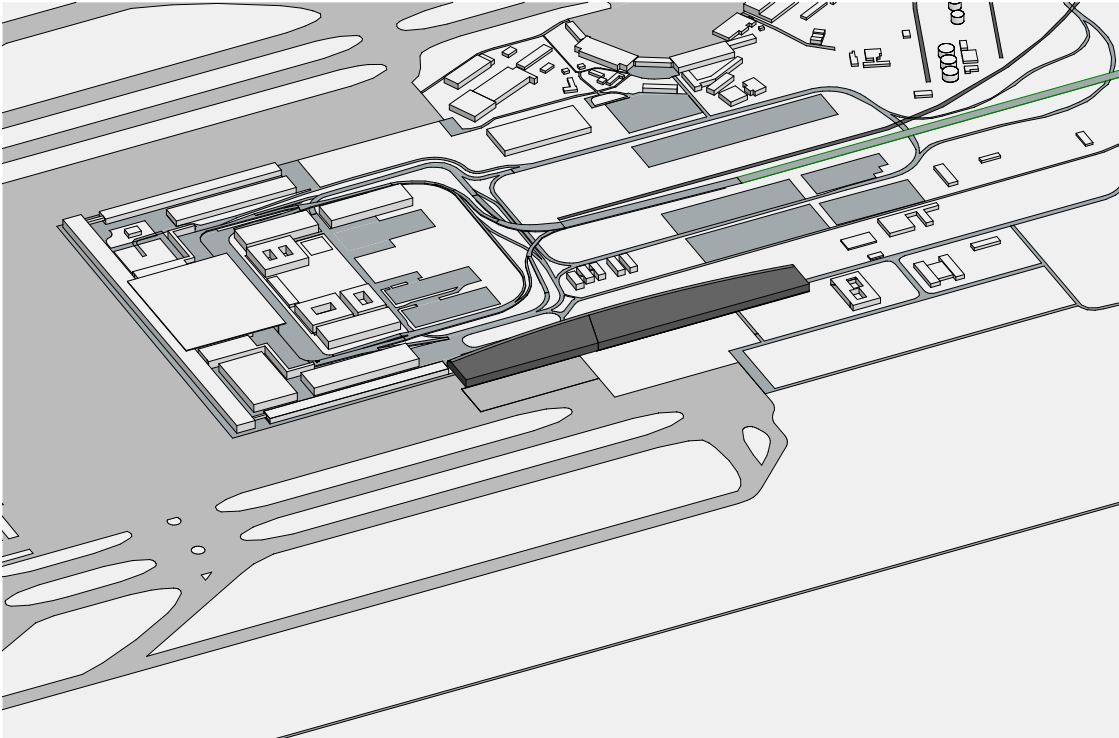

- departures ----->
- arrivals - - - - ->
- airplanes - . - . - .>

# CONCEPT

## SITE - DRIVE THROUGH

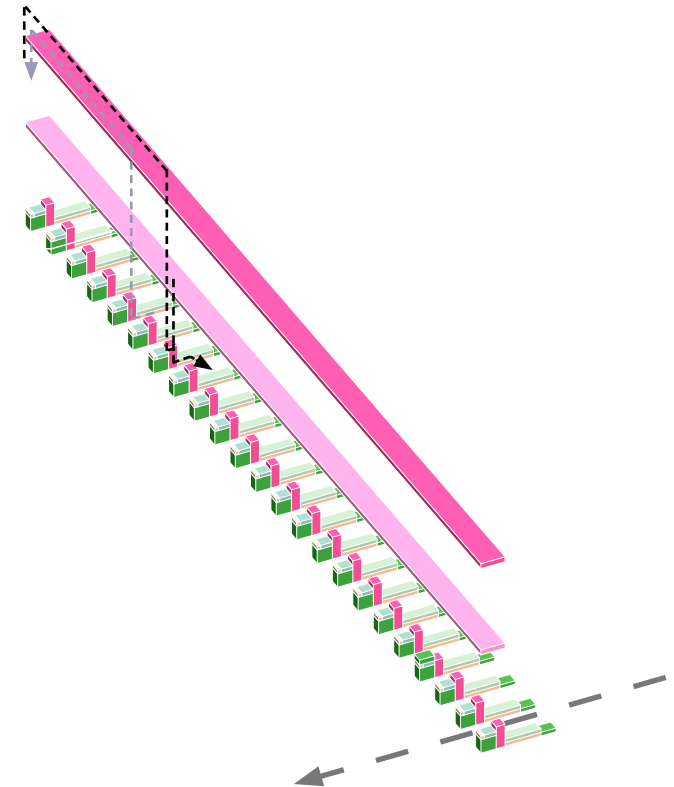
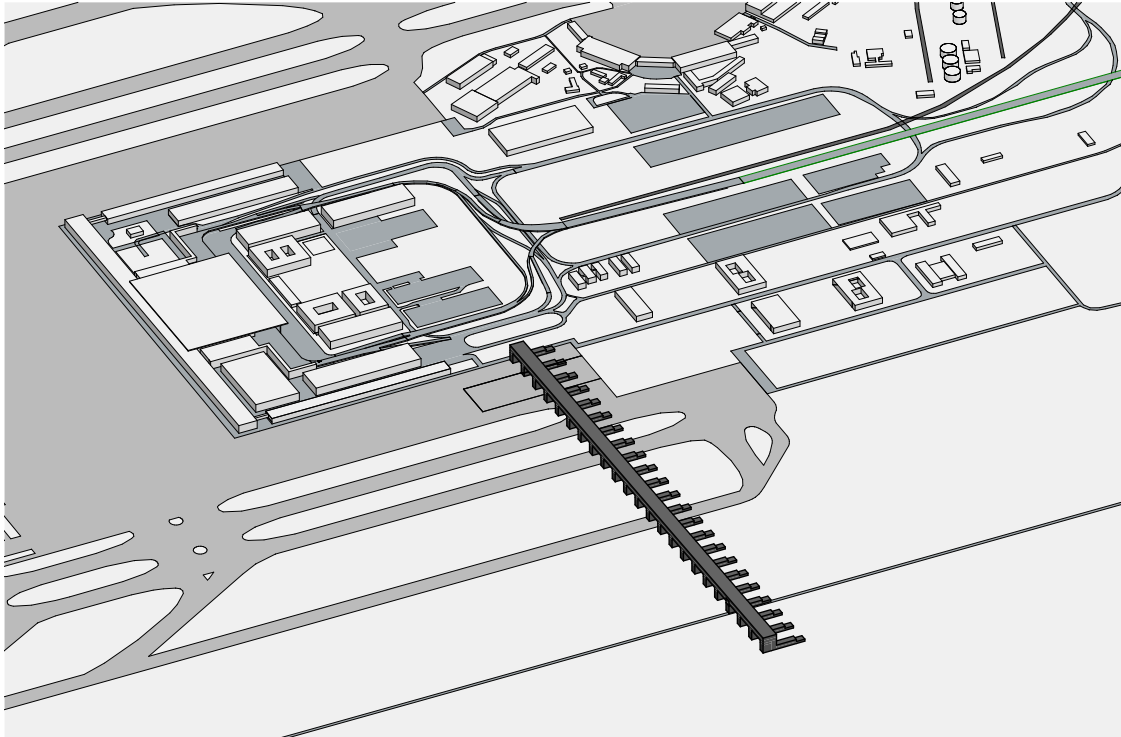

- departures ----->
- arrivals - - - ->
- airplanes - - - ->

# CONCEPT PROGRAM

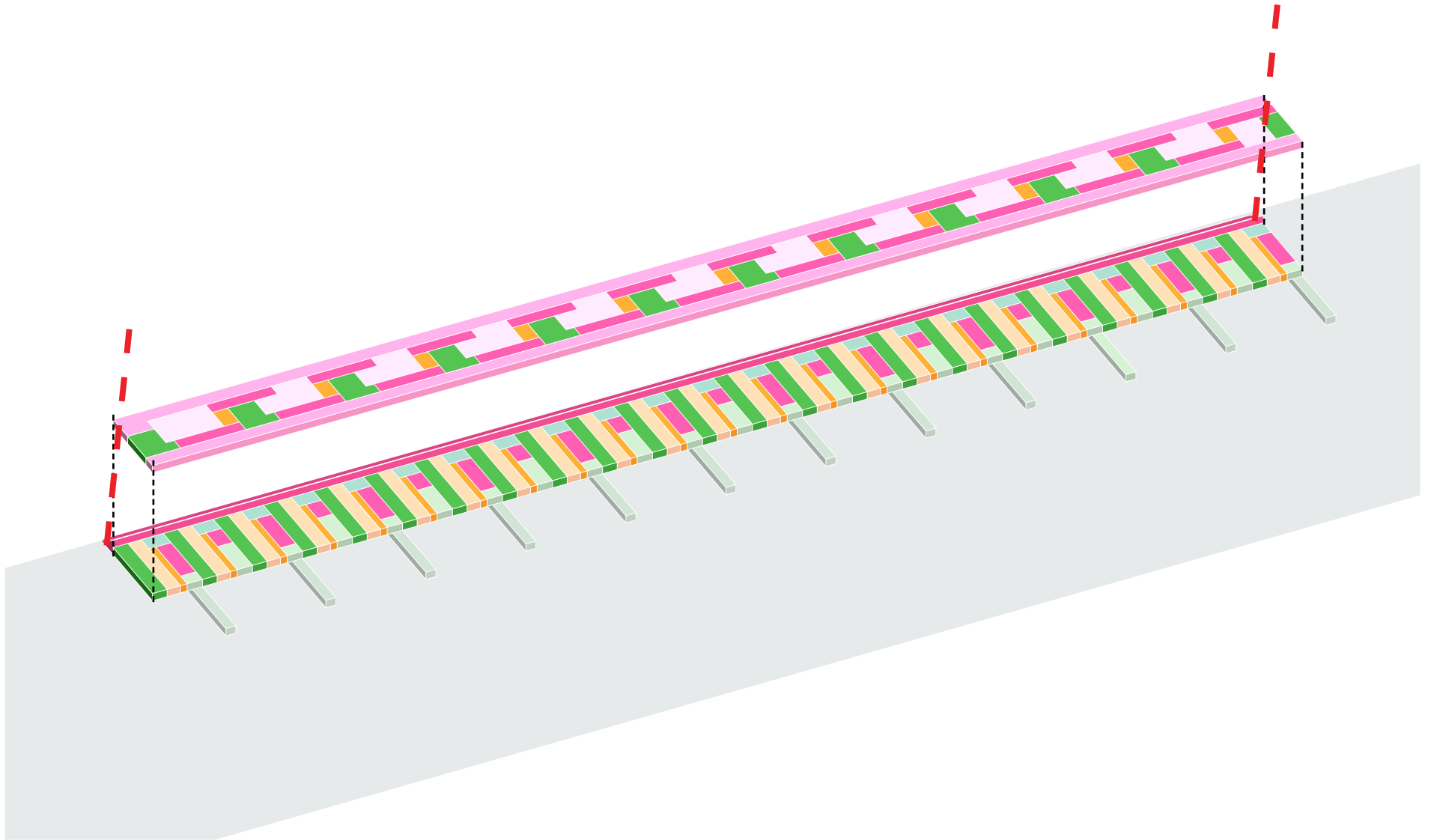



# CONCEPT ROUTING

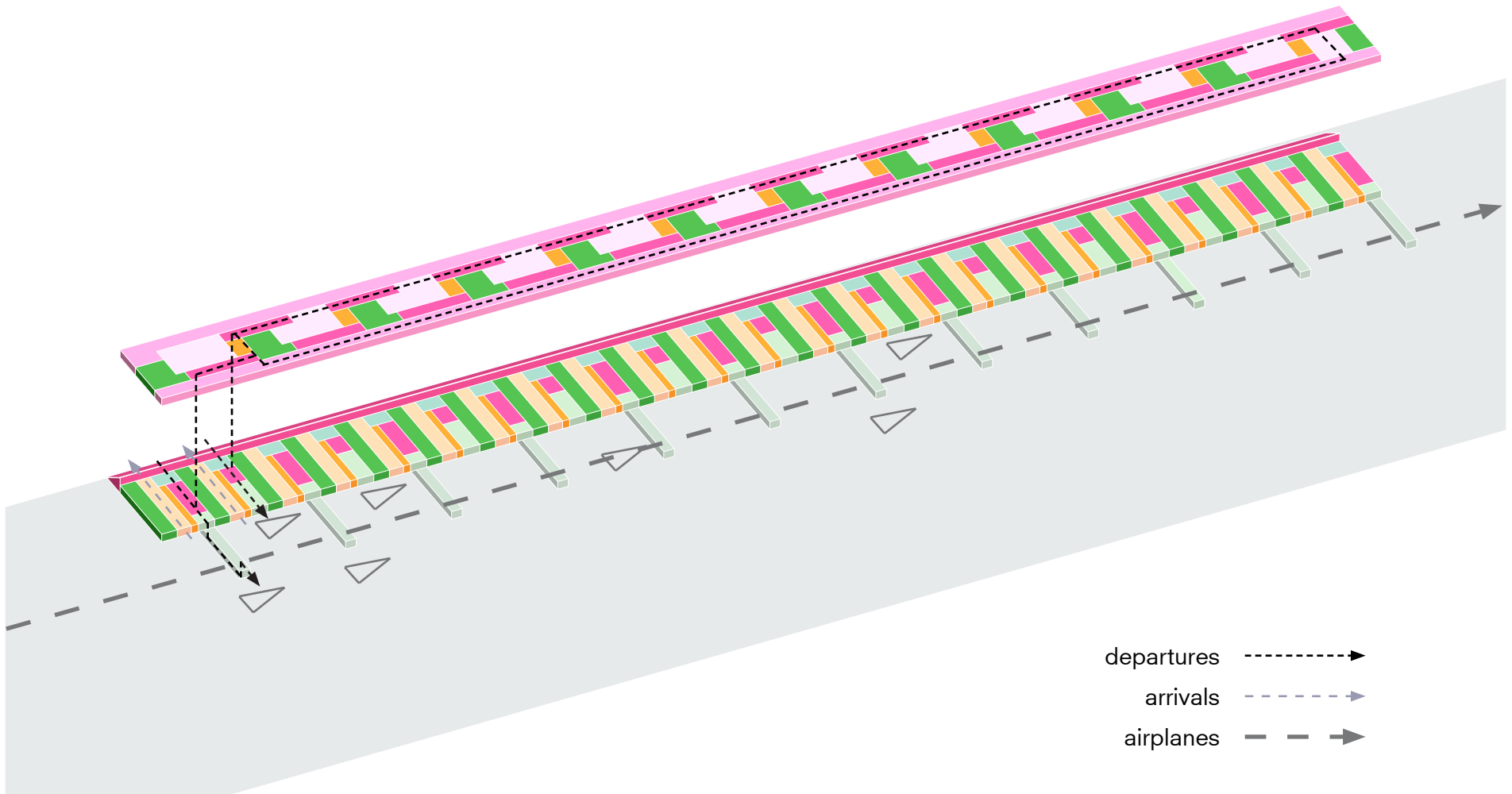

# CONCEPT MASSING

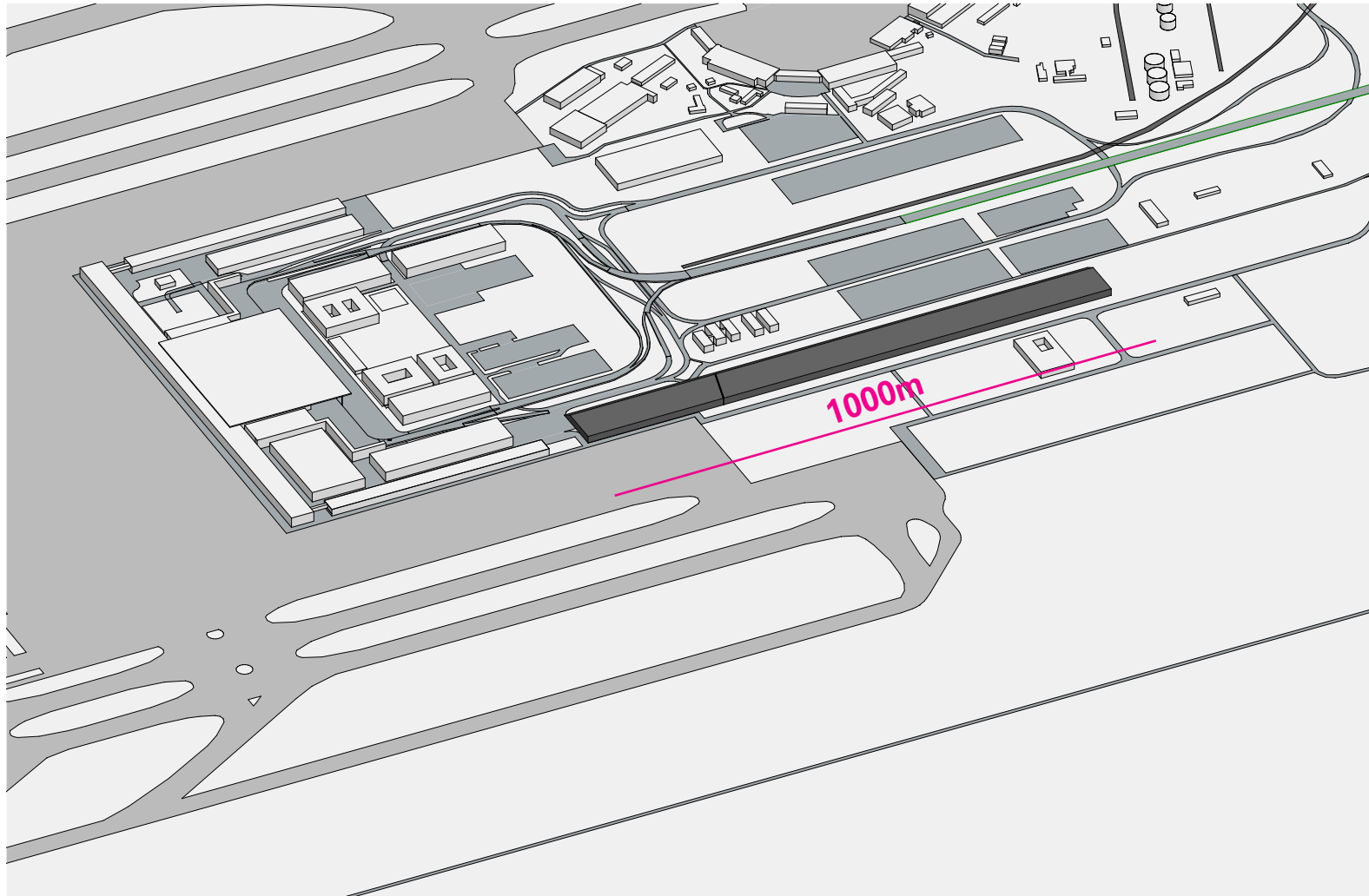

01 INTRODUCTION

02 RESEARCH

& DESIGN BRIEF

04 CONCEPT

**05 IMPLEMENTATION**

06 DEVELOPMENT

07 CONCLUSION

# IMPLEMENTATION MASTERPLAN

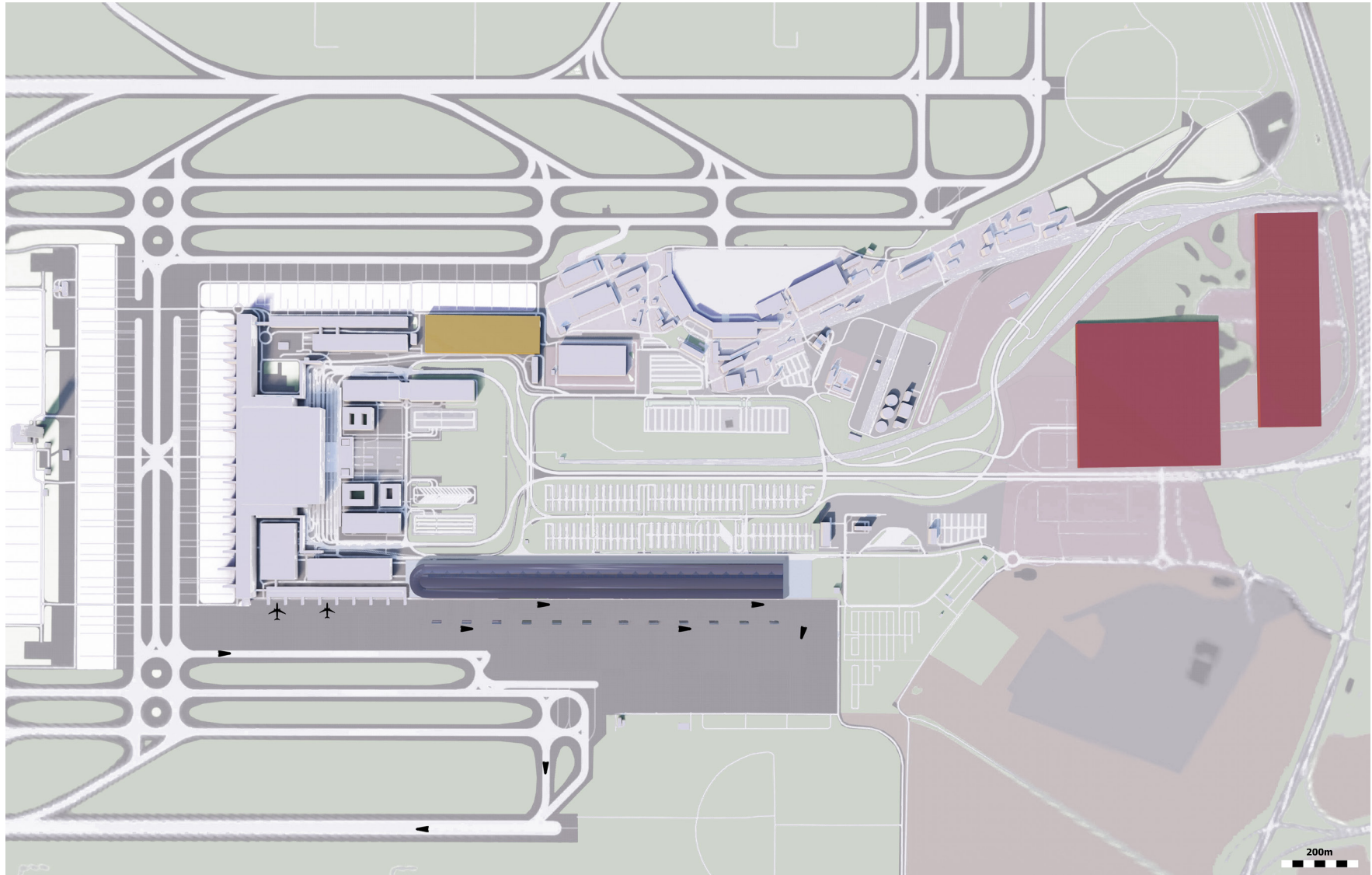

# IMPLEMENTATION MASTERPLAN & ENERGY

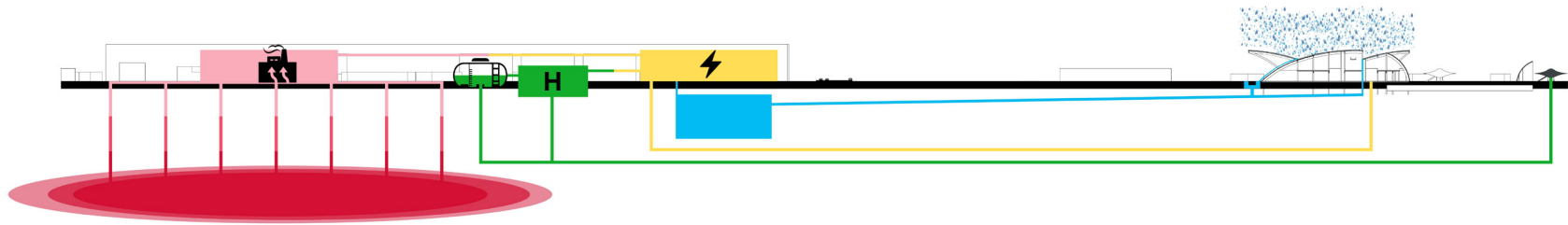

# IMPLEMENTATION

## MASTERPLAN & CONNECTIONS



# IMPLEMENTATION

## MASTERPLAN & CONNECTIONS



# IMPLEMENTATION

## MASTERPLAN & CONNECTIONS

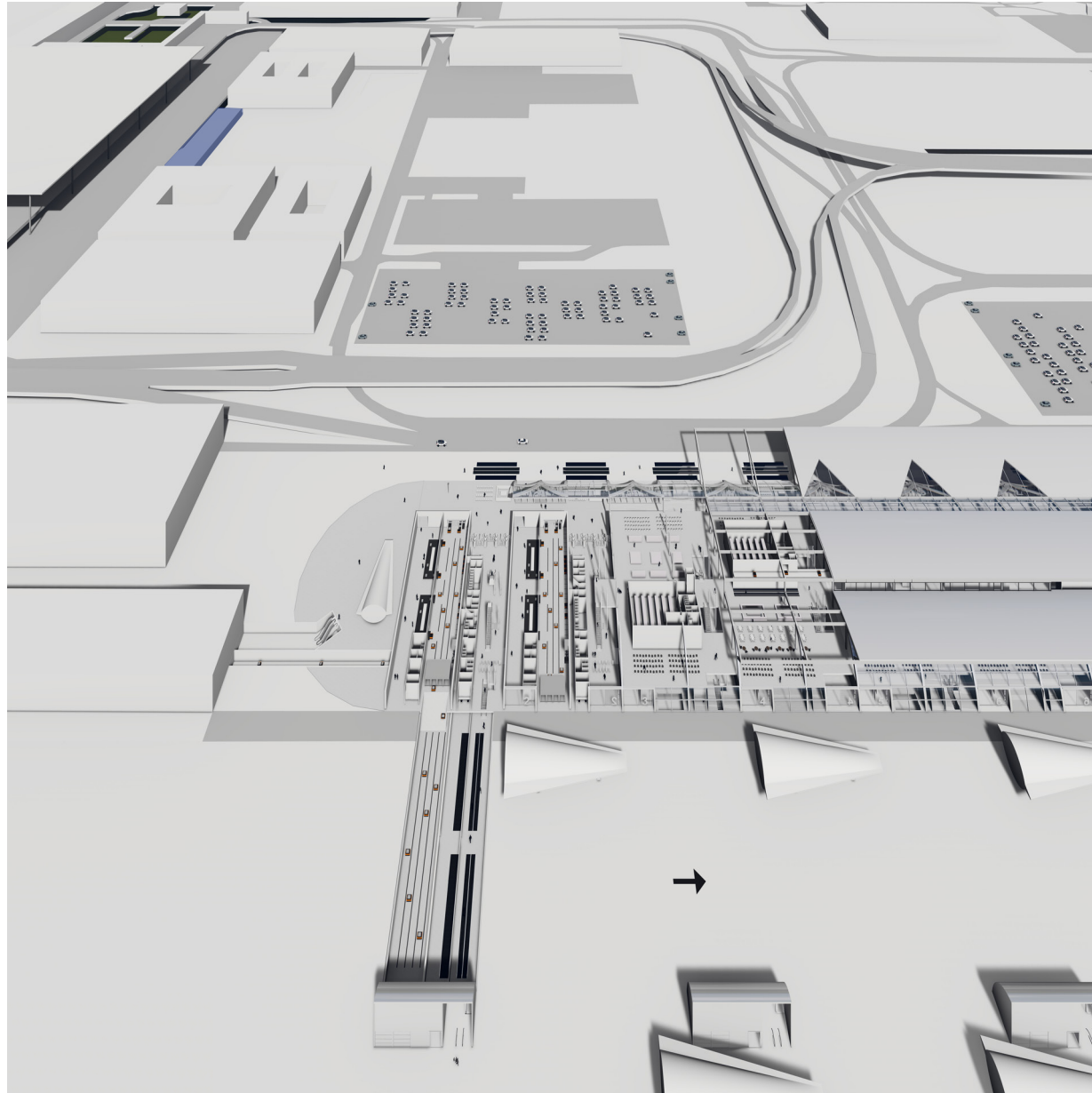



# IMPLEMENTATION MASTERPLAN & CONNECTIONS

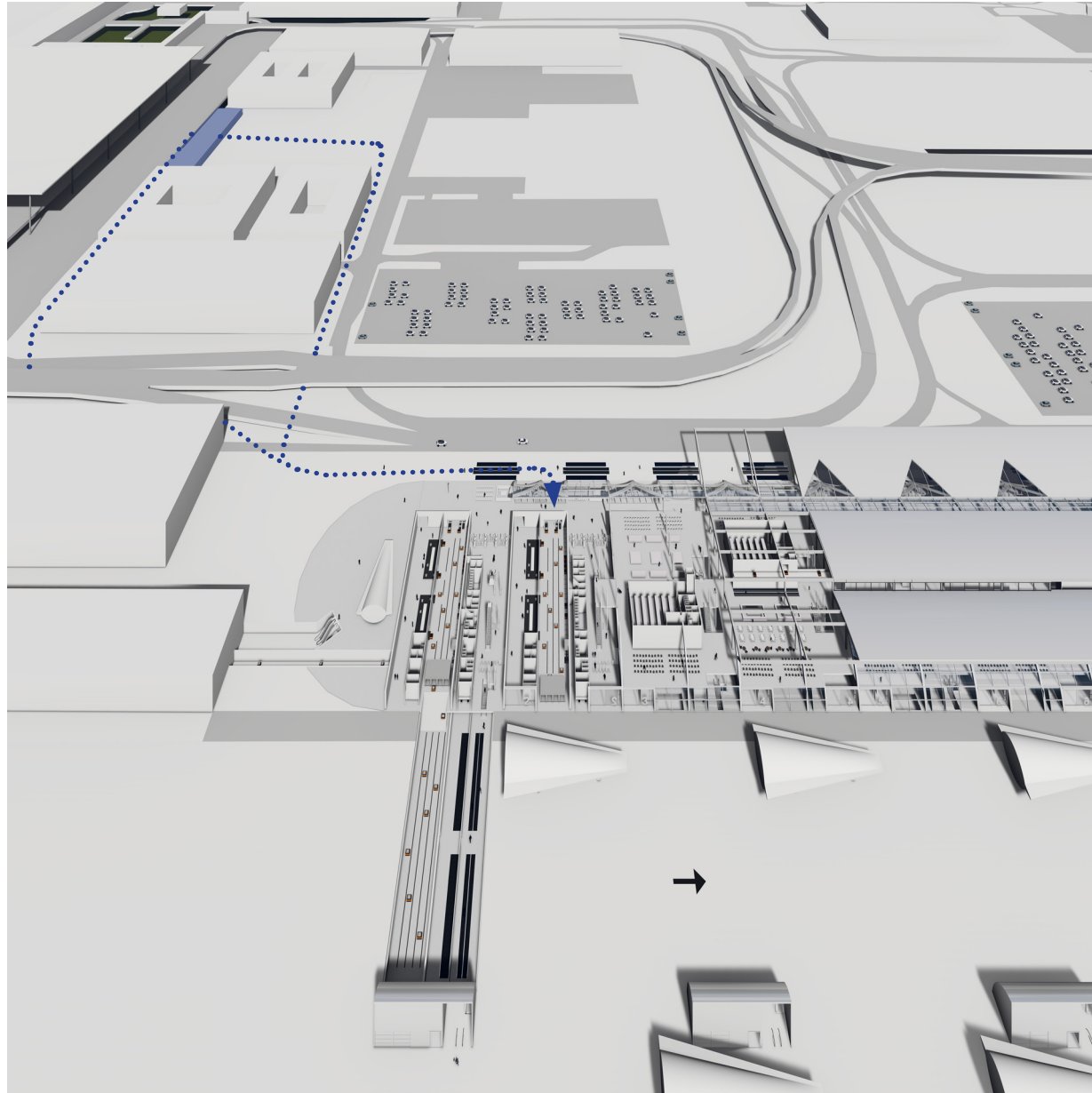

# IMPLEMENTATION MASTERPLAN & CONNECTIONS

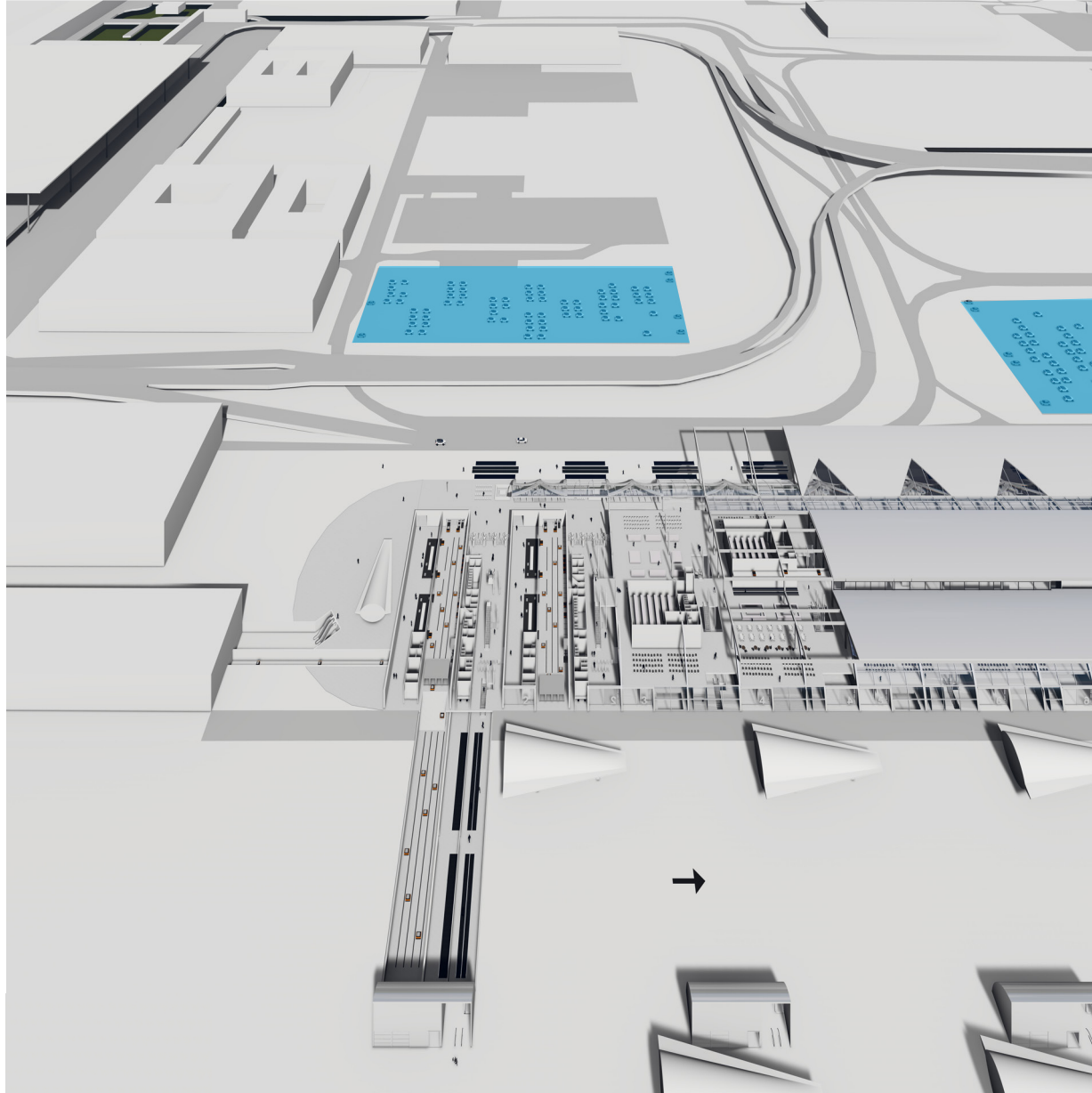

# IMPLEMENTATION MASTERPLAN & CONNECTIONS

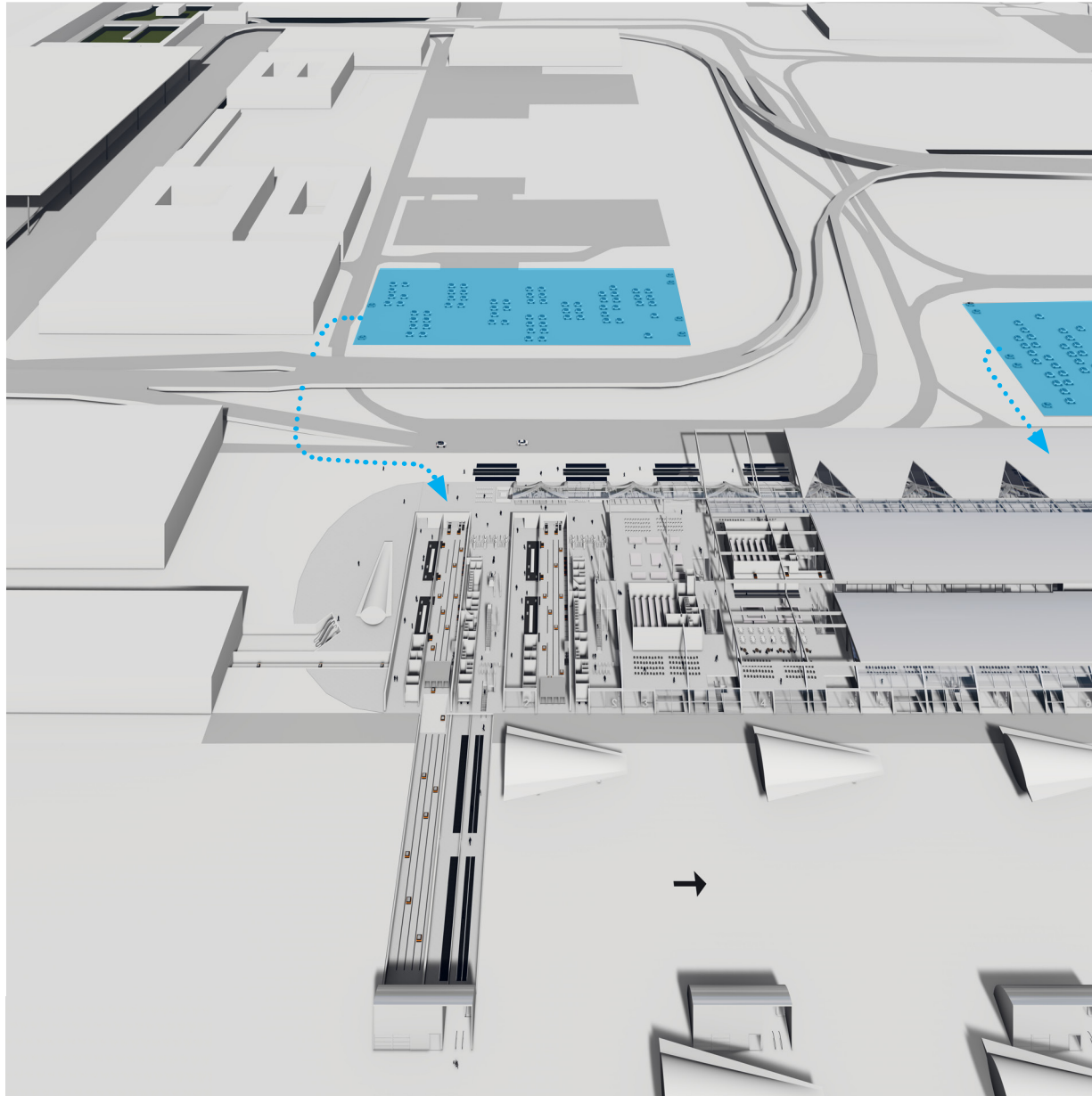

# IMPLEMENTATION SITE PLAN



# IMPLEMENTATION SITE PLAN

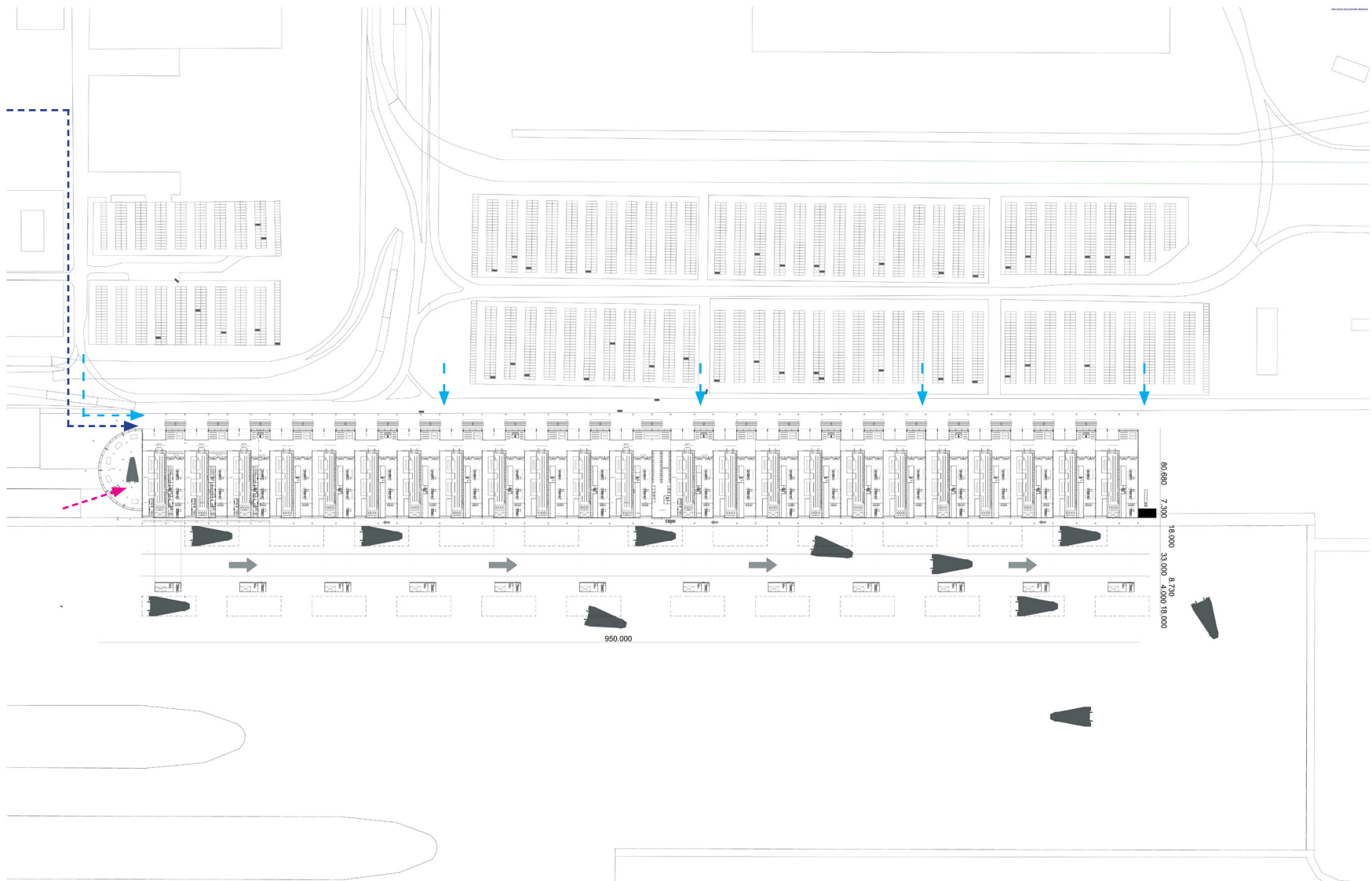

by public transport 

by car 

transfer 

# IMPLEMENTATION FLOOR PLAN

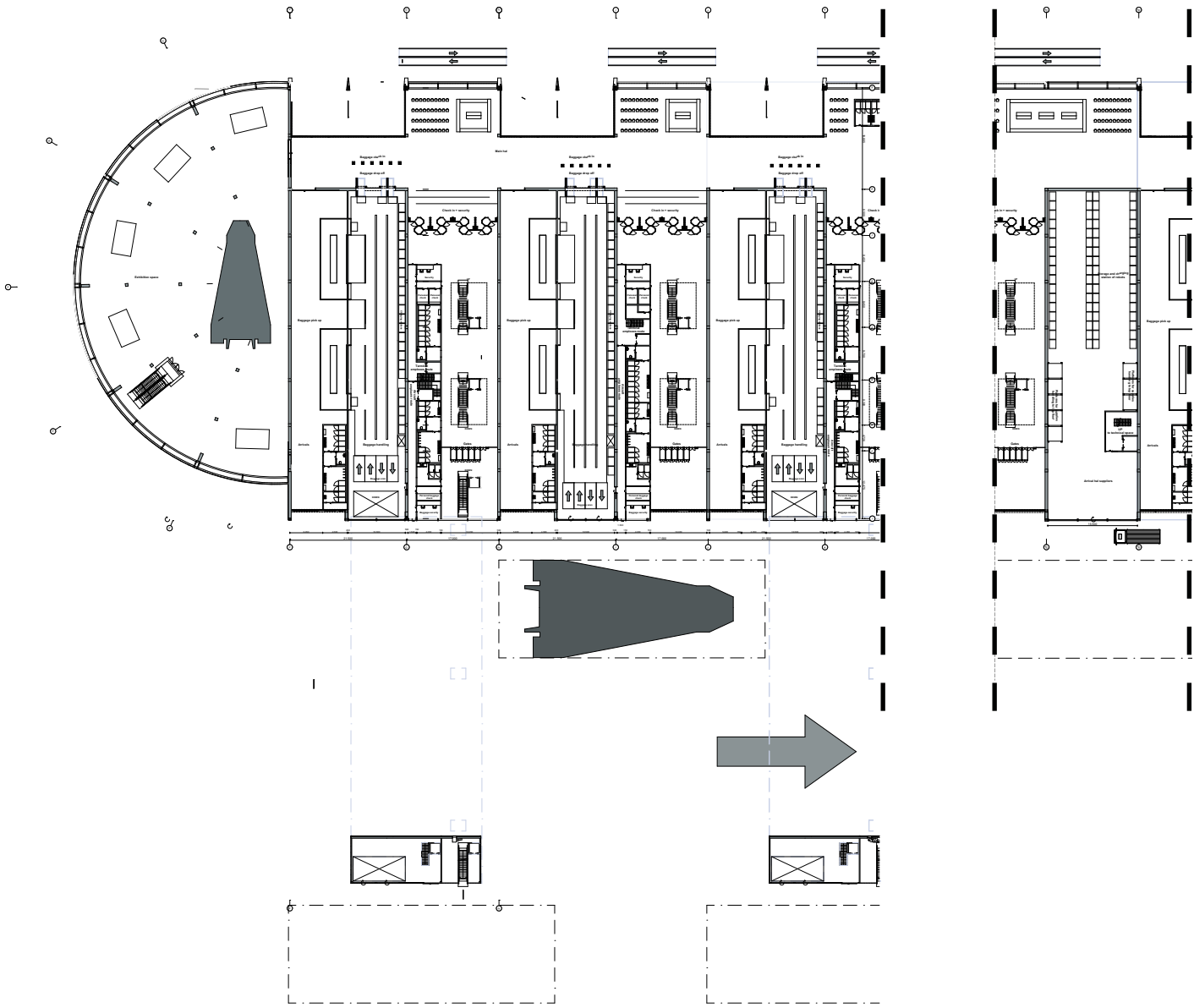

0

# IMPLEMENTATION FLOOR PLAN

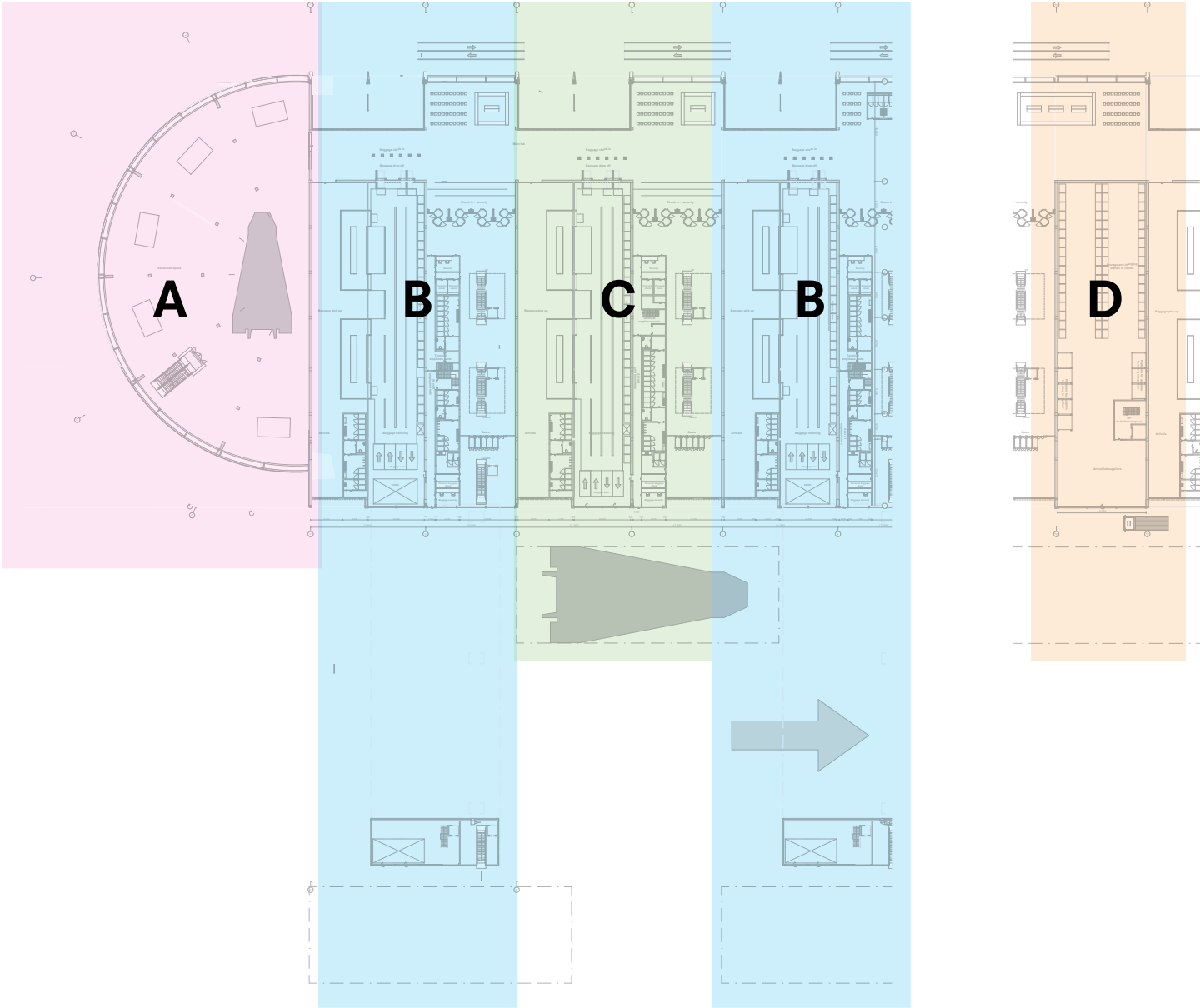

0

# IMPLEMENTATION FLOOR PLAN

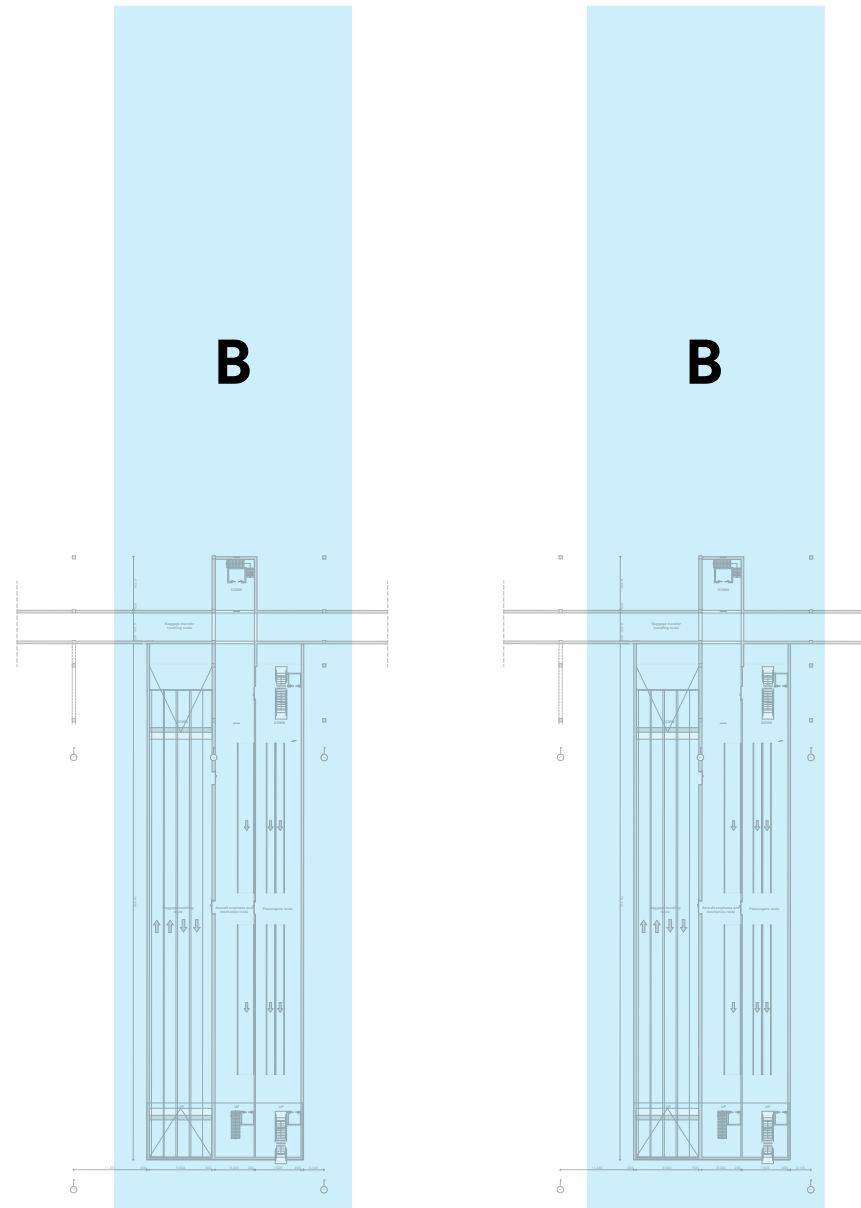

-1



# IMPLEMENTATION FLOOR PLAN

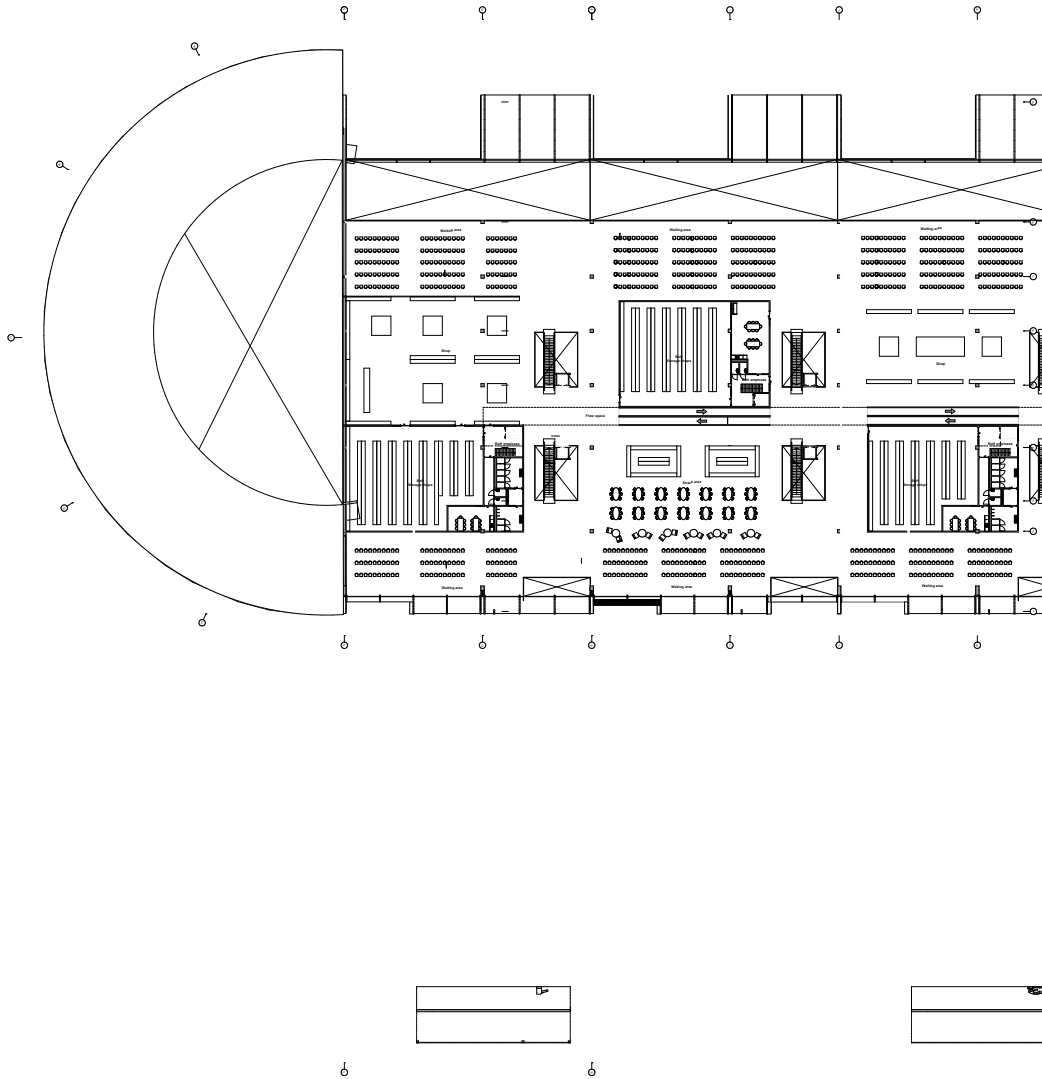

1

# IMPLEMENTATION FLOOR PLAN

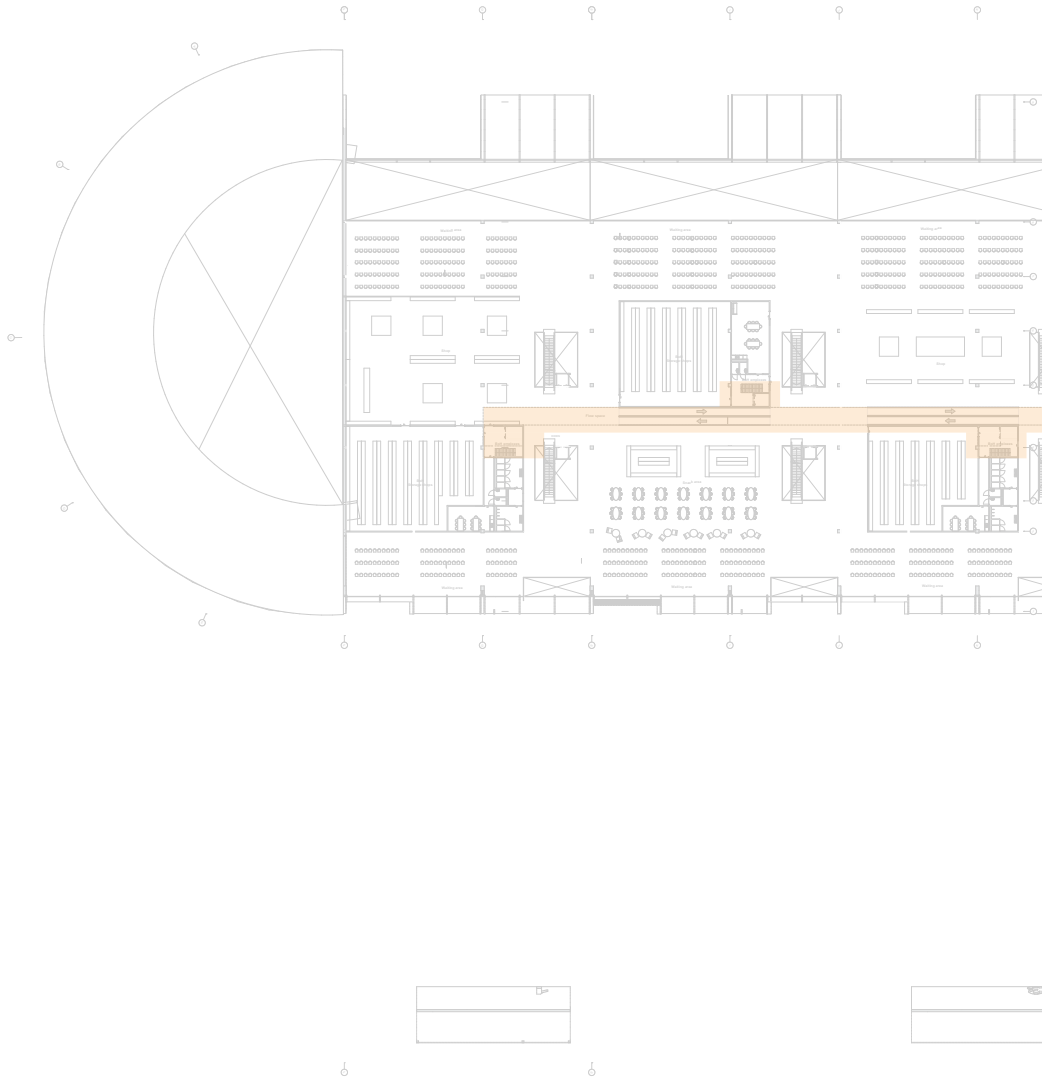

2

# IMPLEMENTATION FLOOR PLAN A

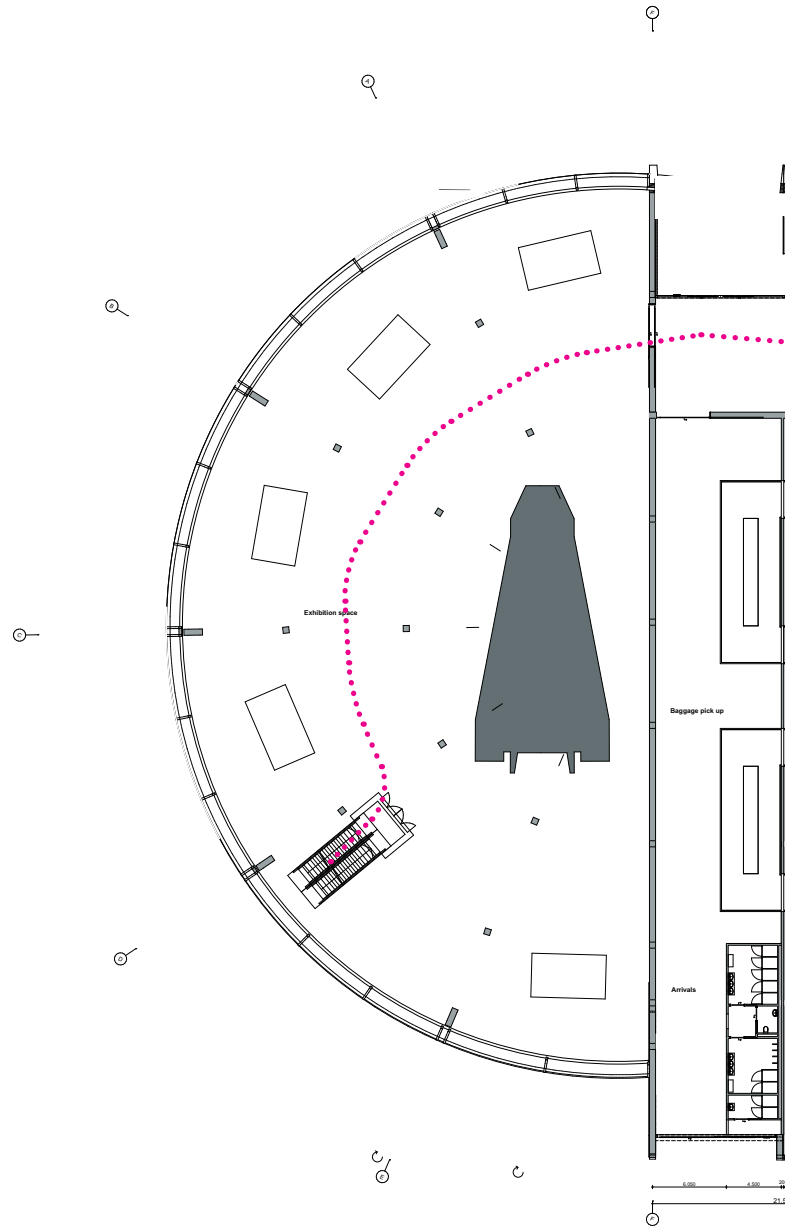

# IMPLEMENTATION FLOOR PLAN B

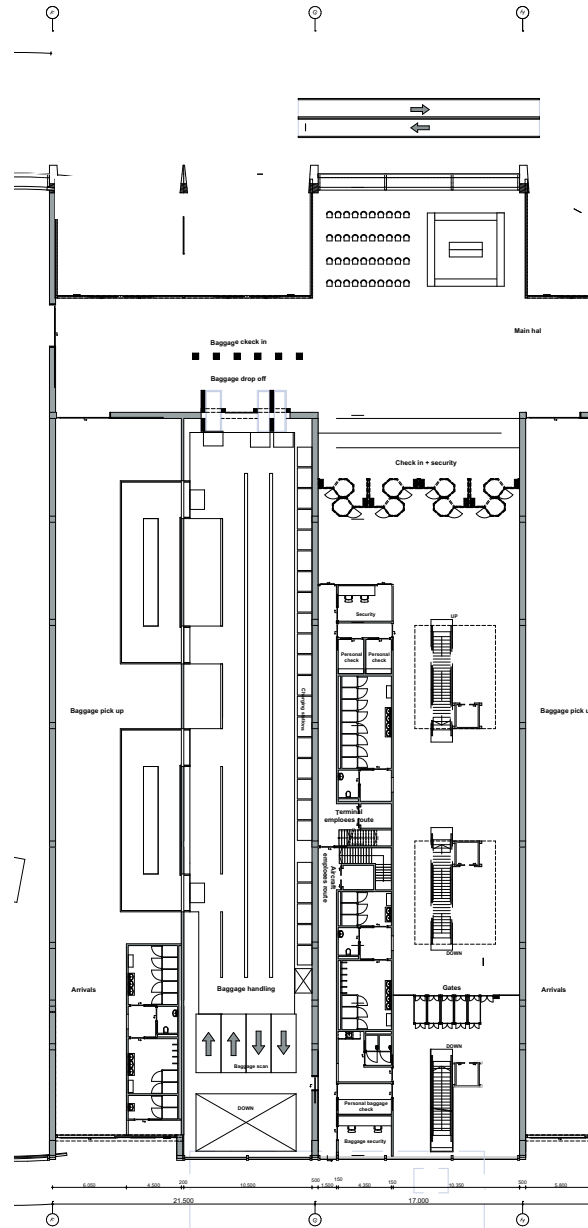

# IMPLEMENTATION

## PART B DIVISION

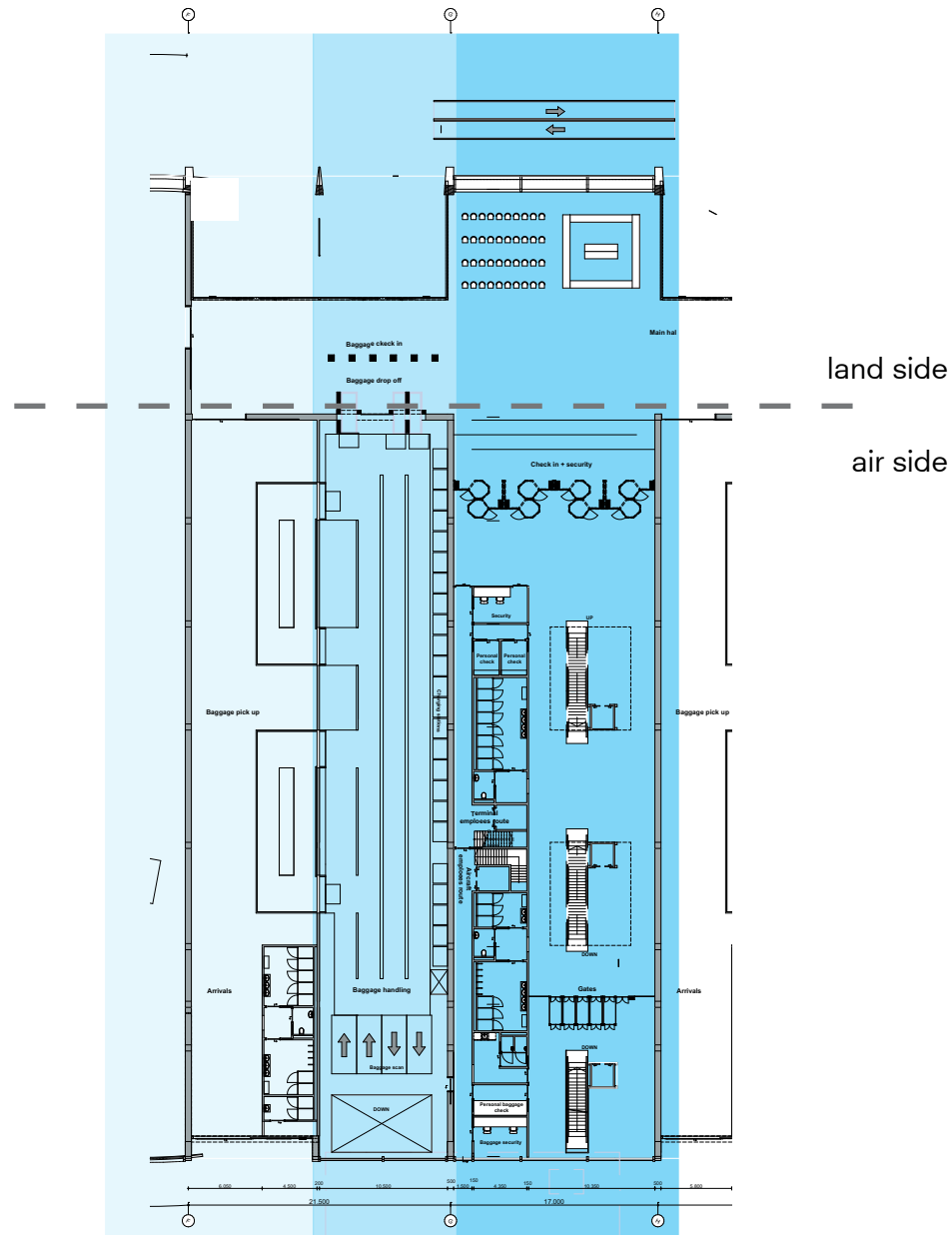

# IMPLEMENTATION

## PART B DIVISION

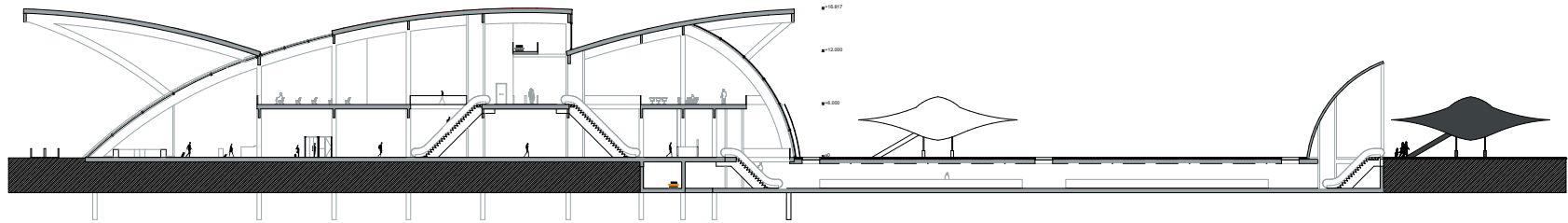

Section departures gate 1

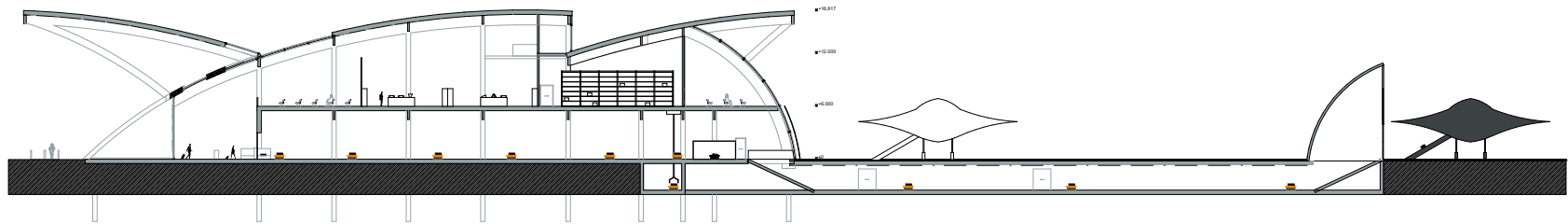

Section baggage handling gate 1

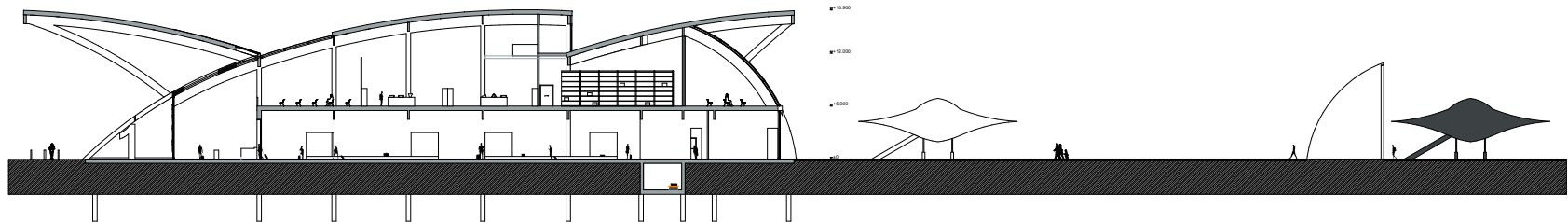

Section arrivals gate 1

# IMPLEMENTATION PART B DIVISION

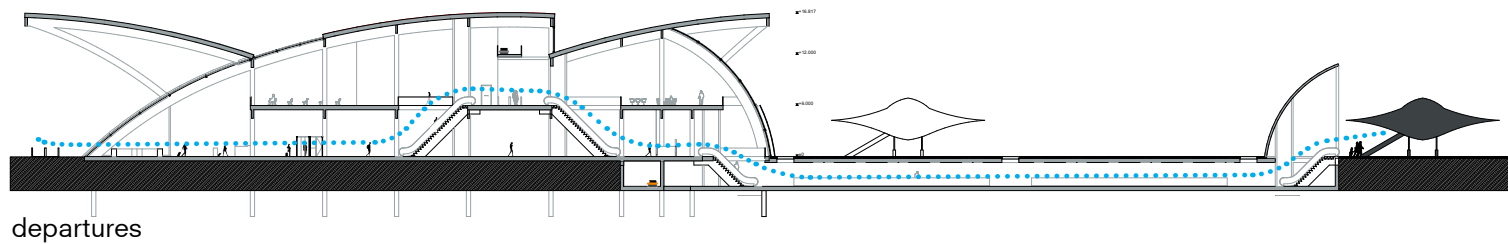
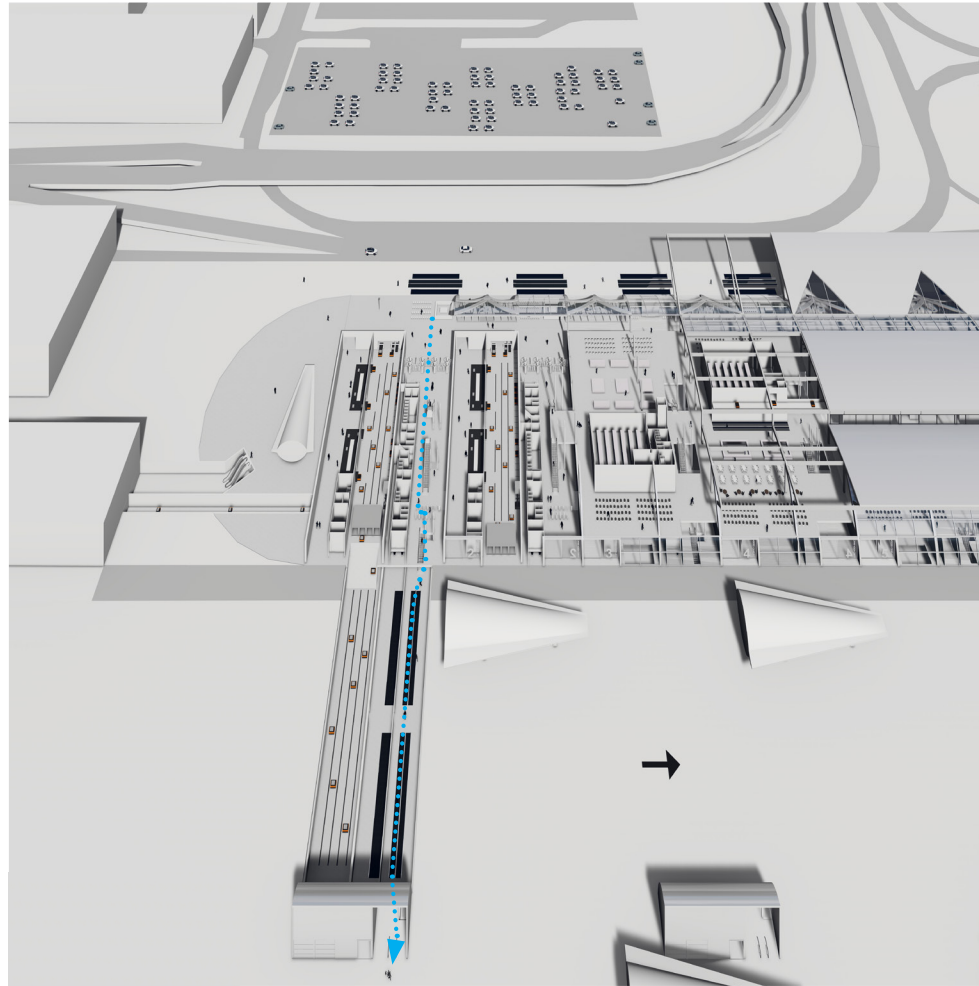

departures

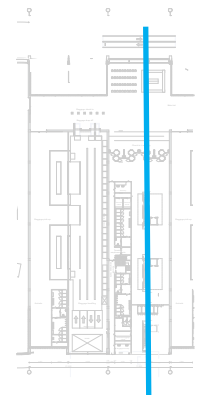

# IMPLEMENTATION PART B DIVISION

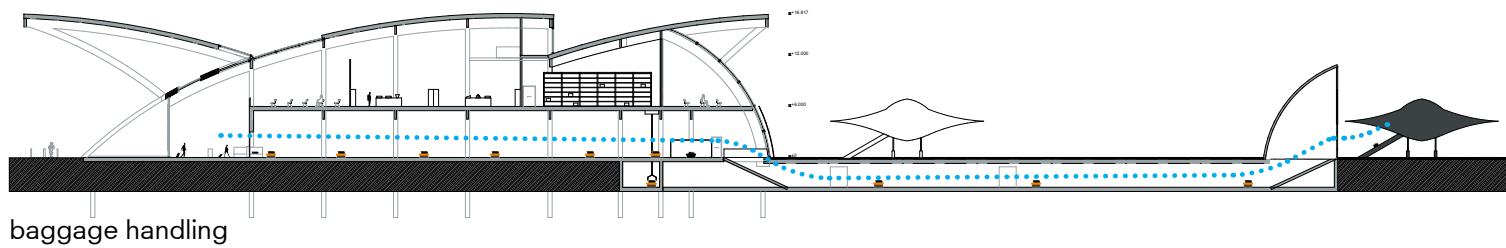
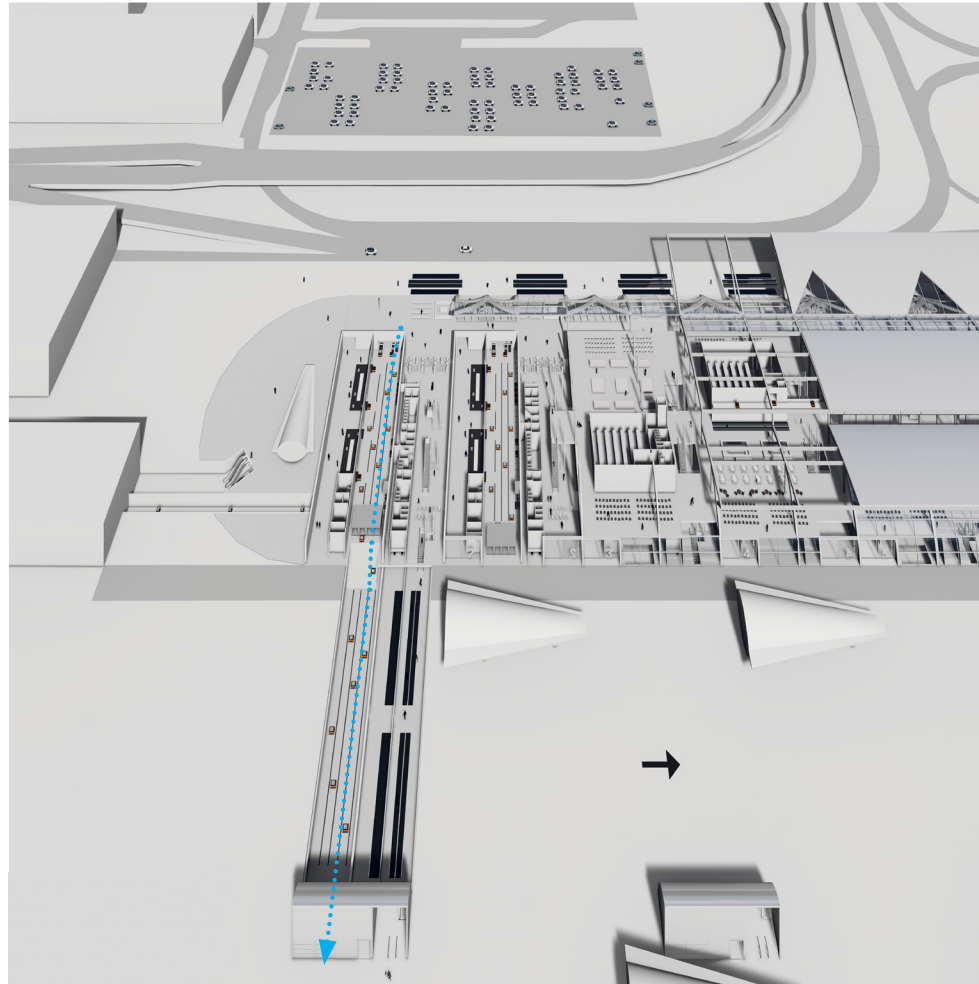

baggage handling

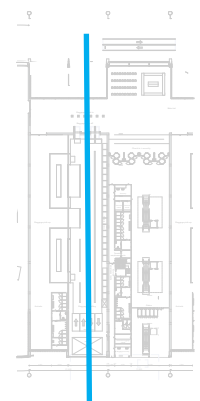



# IMPLEMENTATION PART B DIVISION

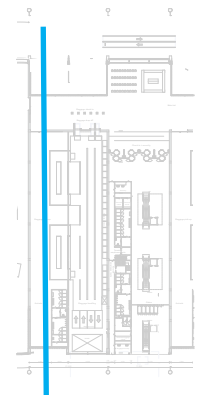
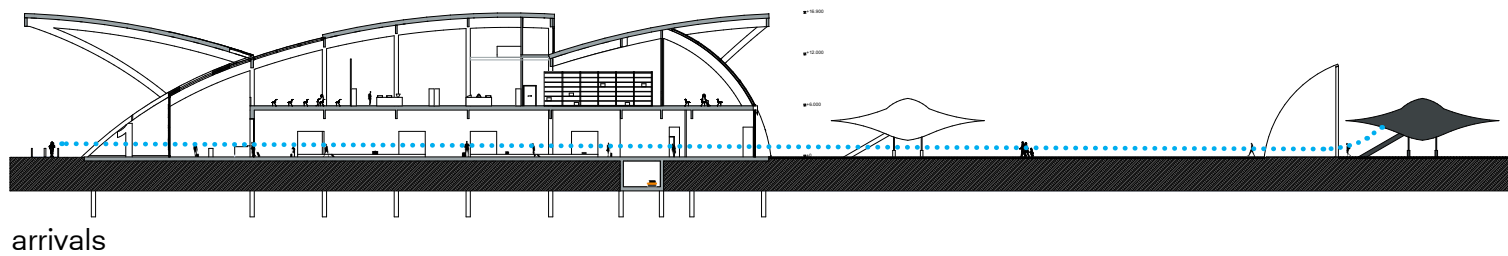
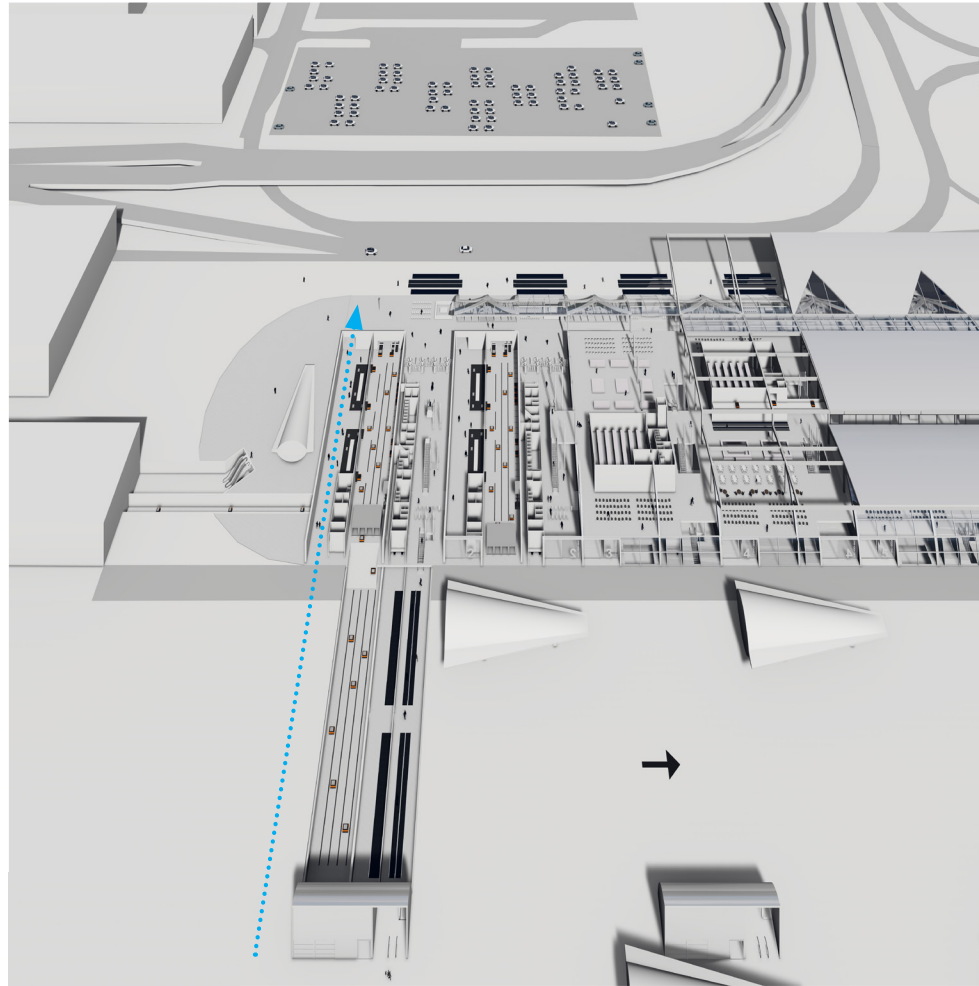

# IMPLEMENTATION

## PART B DEPARTURES

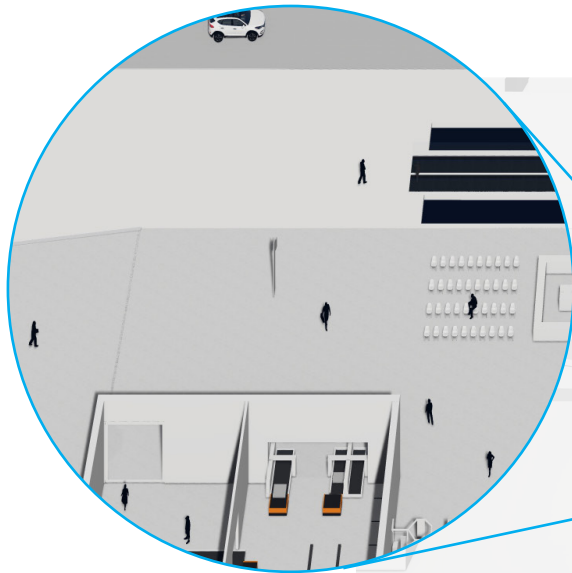

entrance

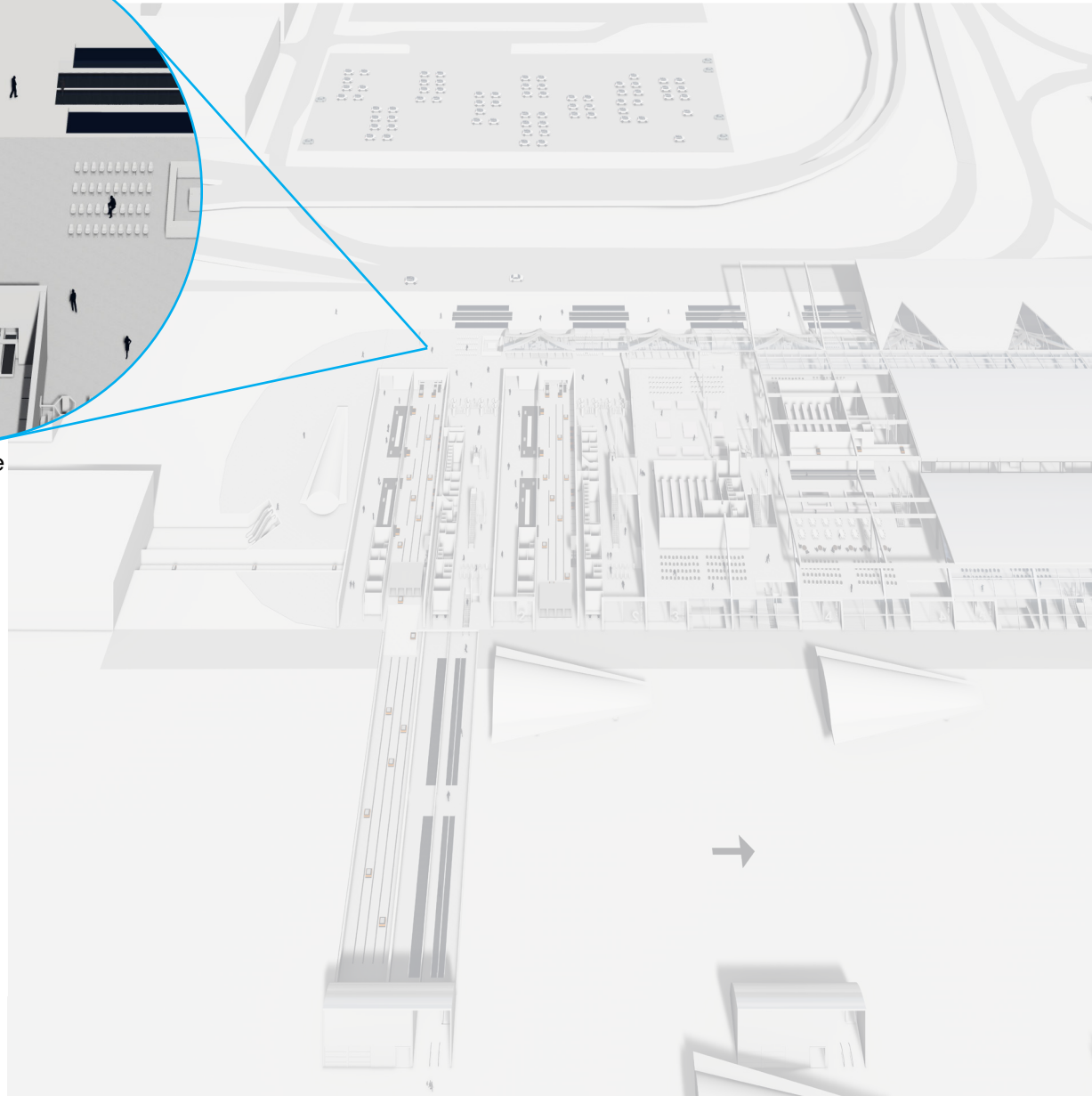

# IMPLEMENTATION

## PART B DEPARTURES



baggage drop off

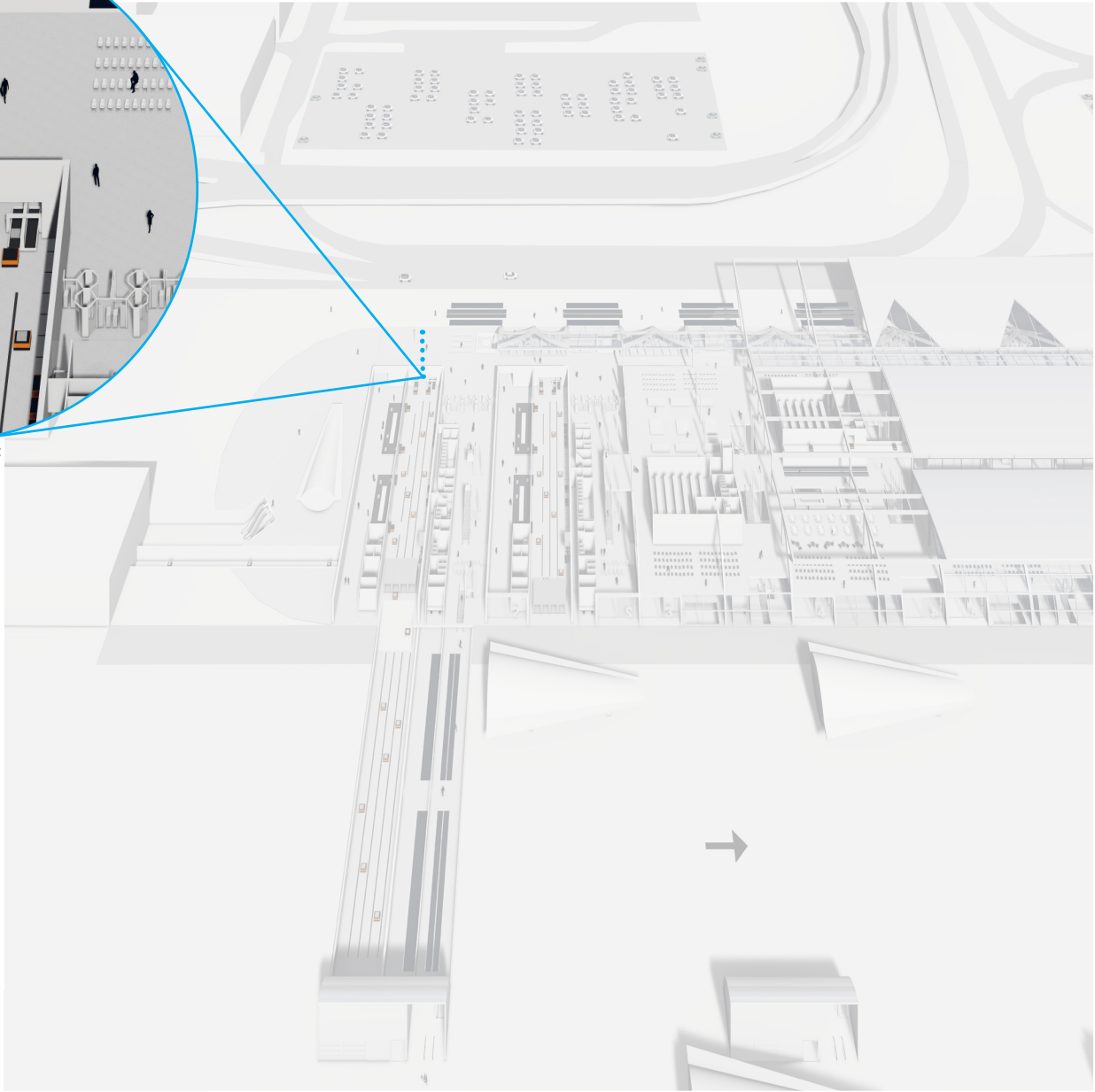

# IMPLEMENTATION

## PART B DEPARTURES



security & check in

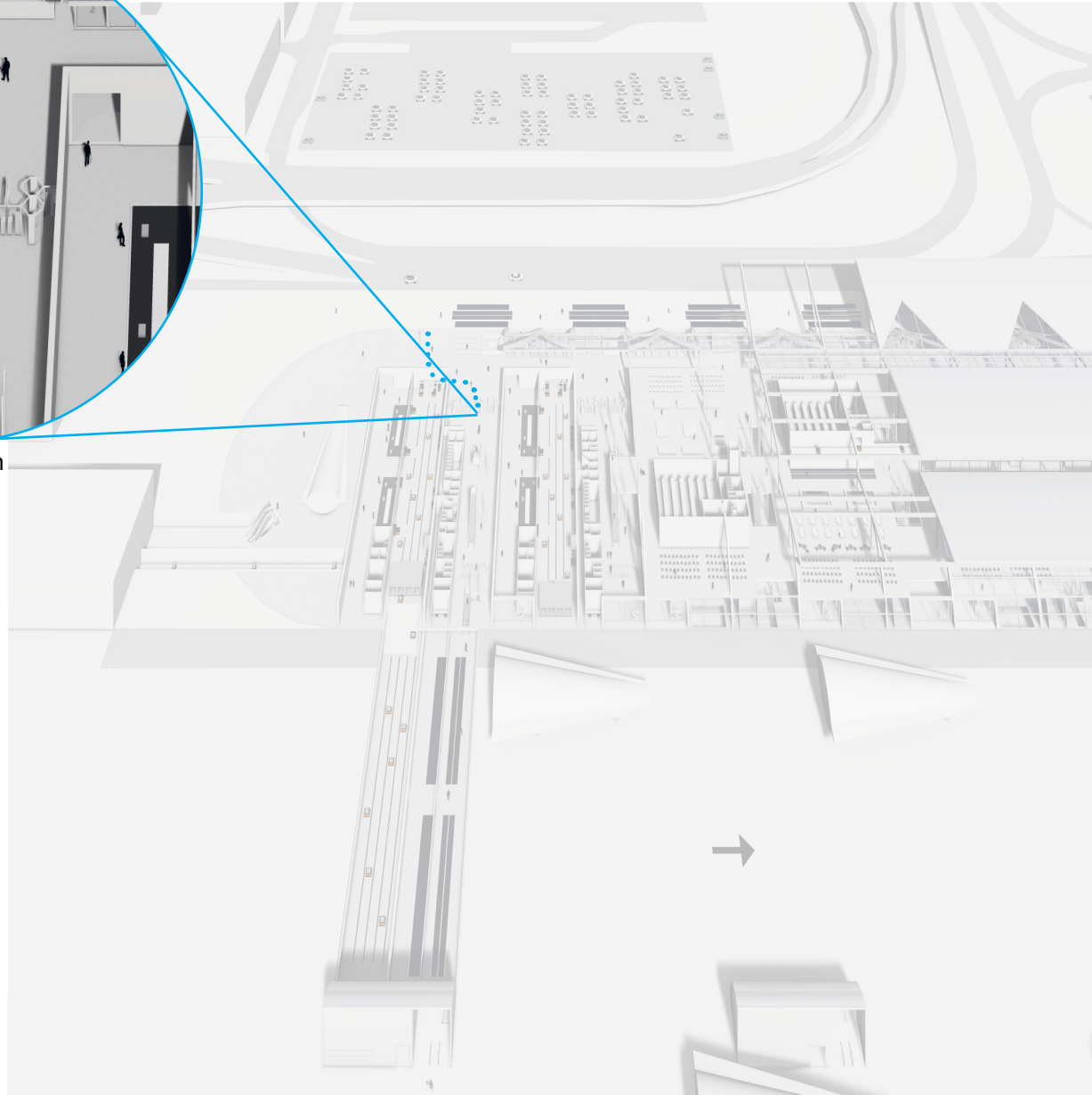

# IMPLEMENTATION

## PART B DEPARTURES

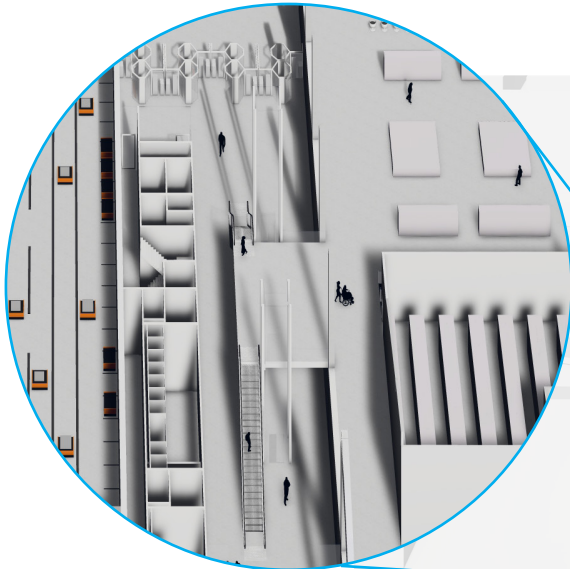

escalator to shops  
& waiting

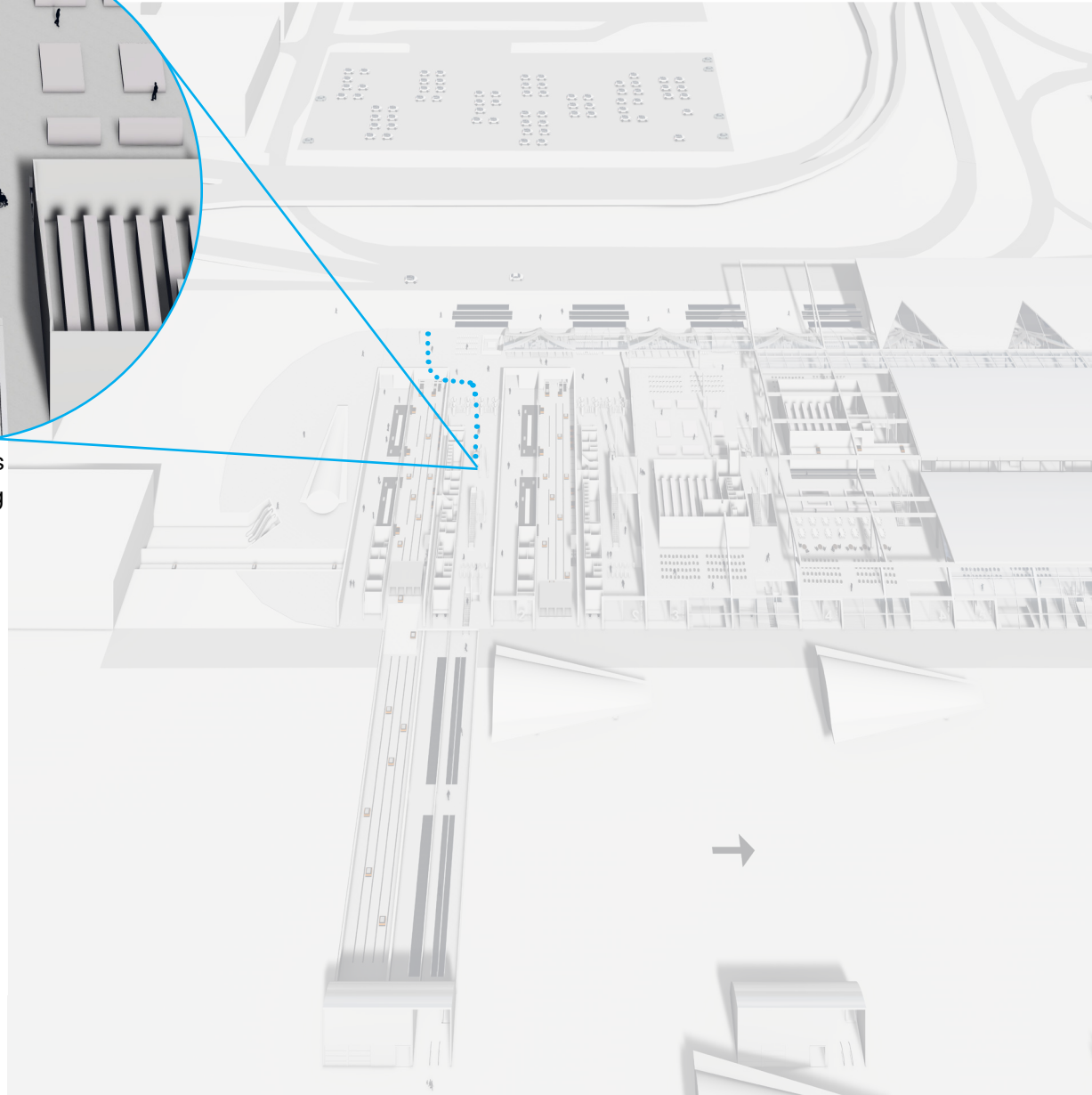

# IMPLEMENTATION

## PART B DEPARTURES

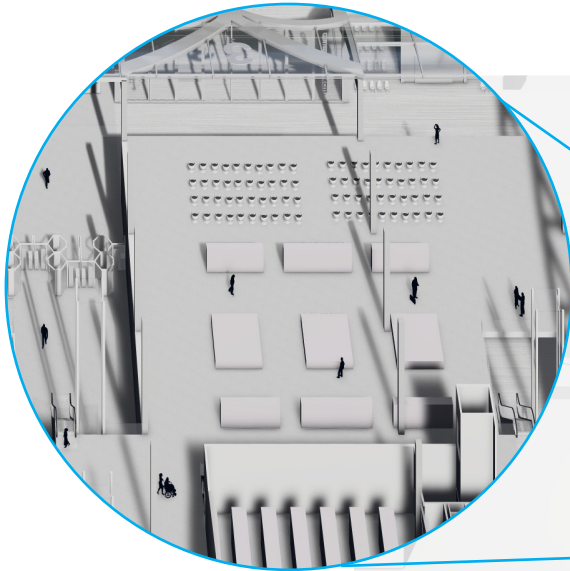

waiting & shops

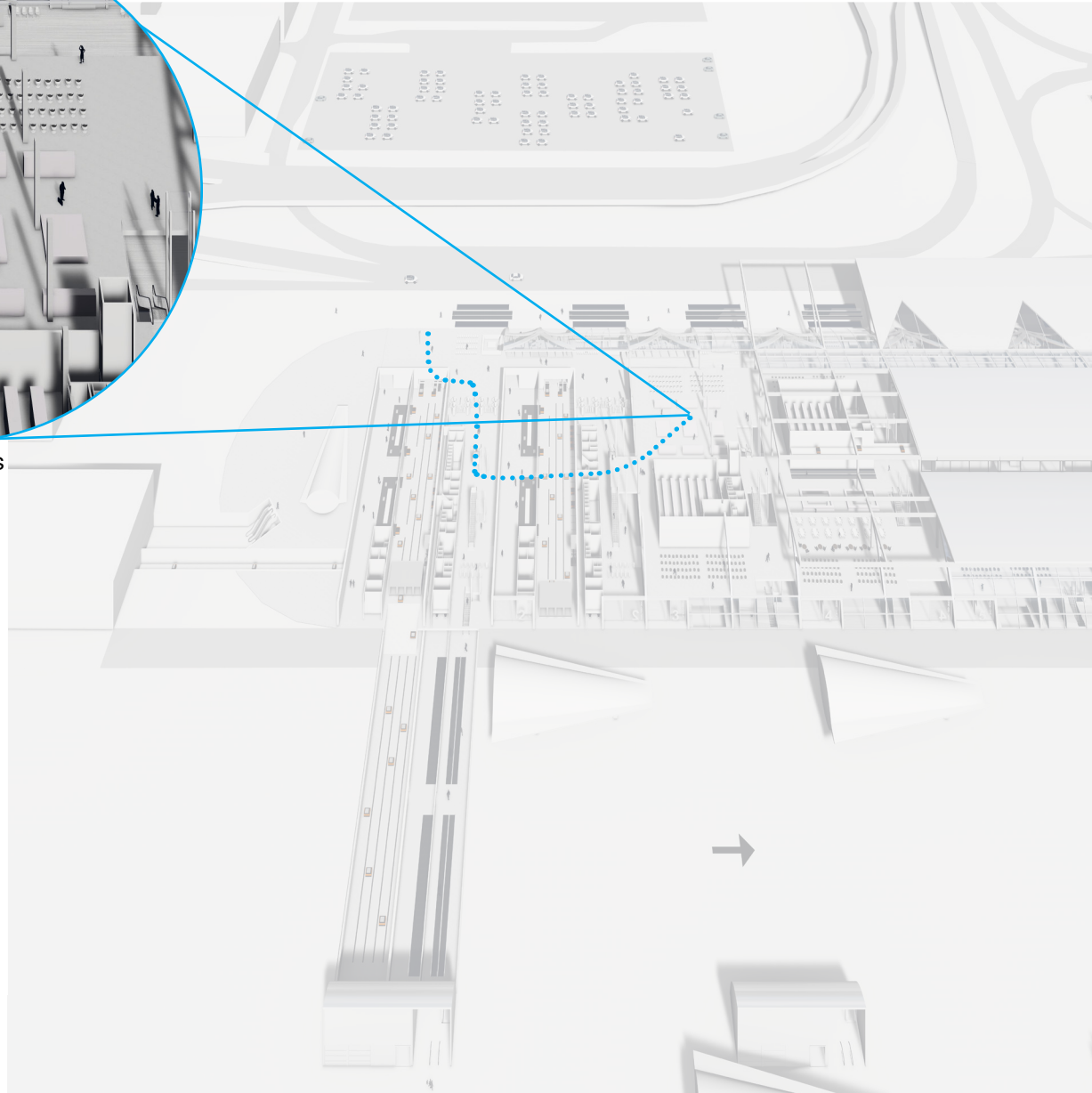

# IMPLEMENTATION

## PART B DEPARTURES

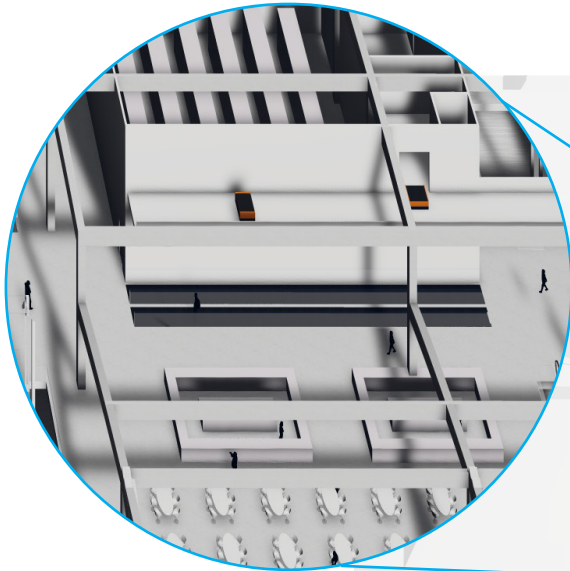

flow space

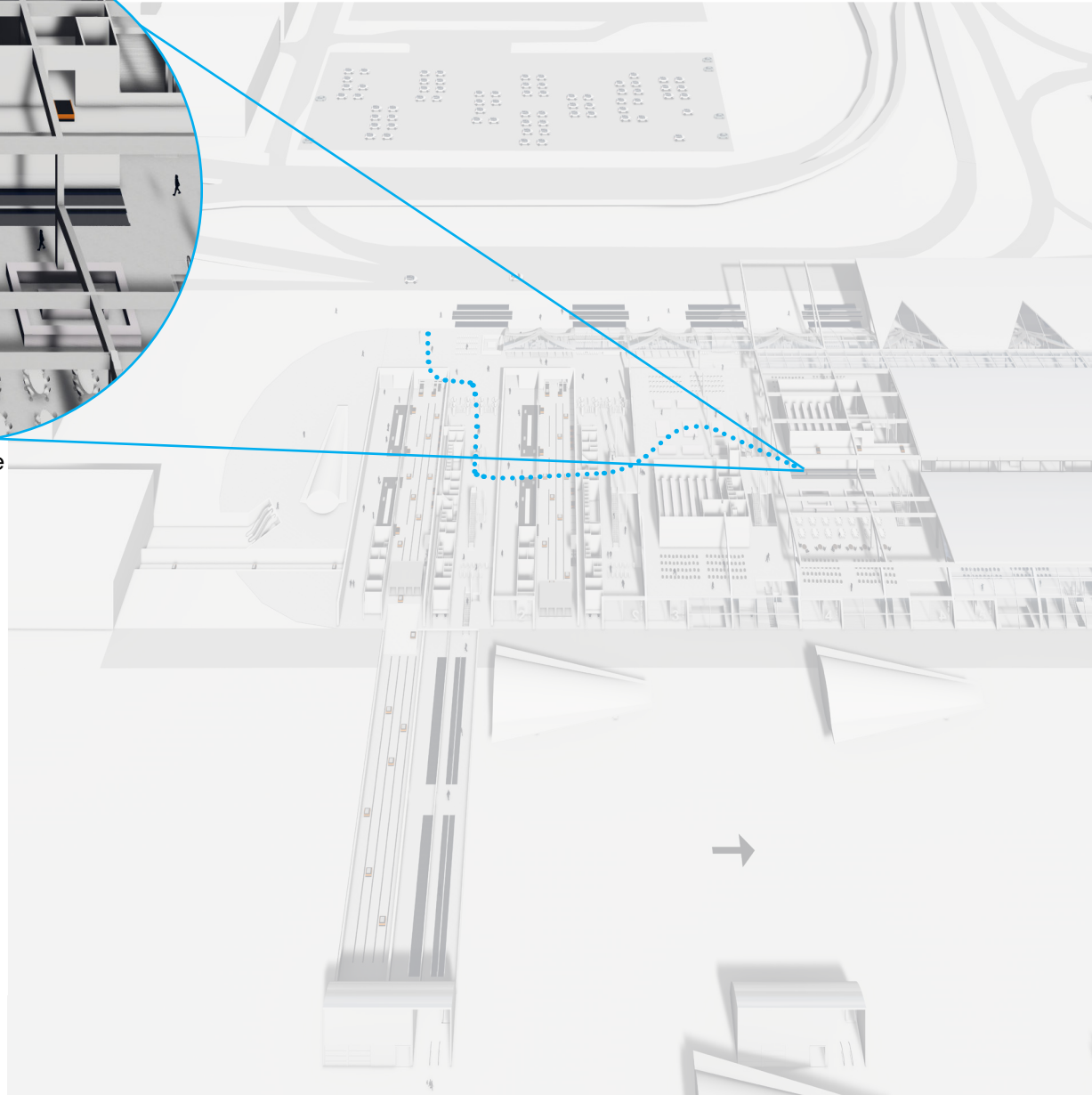

# IMPLEMENTATION

## PART B DEPARTURES

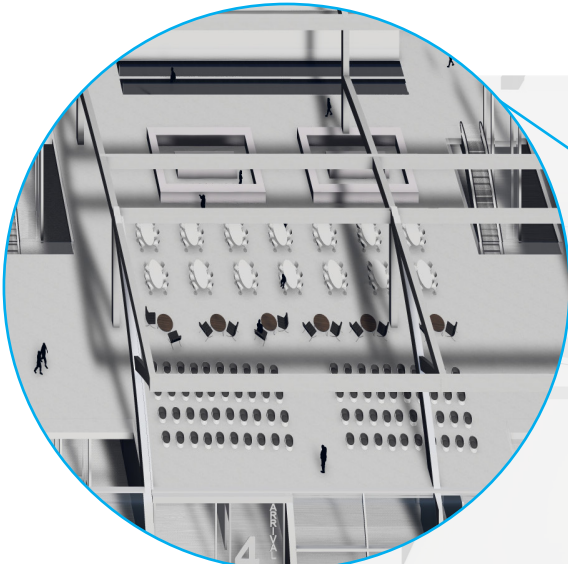

eating area





# IMPLEMENTATION

## PART B DEPARTURES

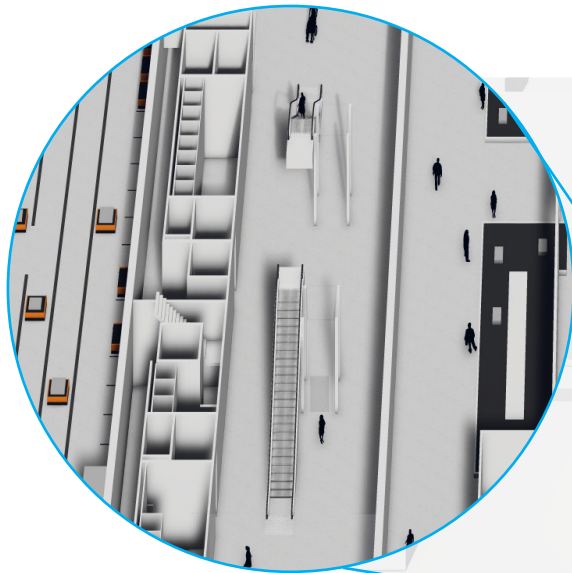

escalator to go down



# IMPLEMENTATION

## PART B DEPARTURES

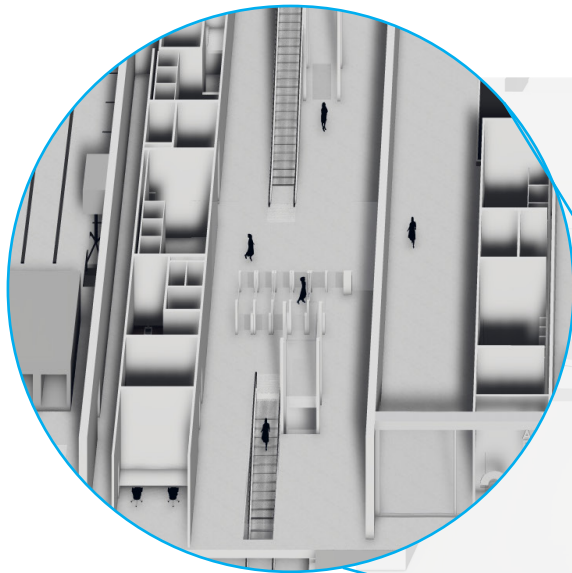

gate



# IMPLEMENTATION

## PART B DEPARTURES

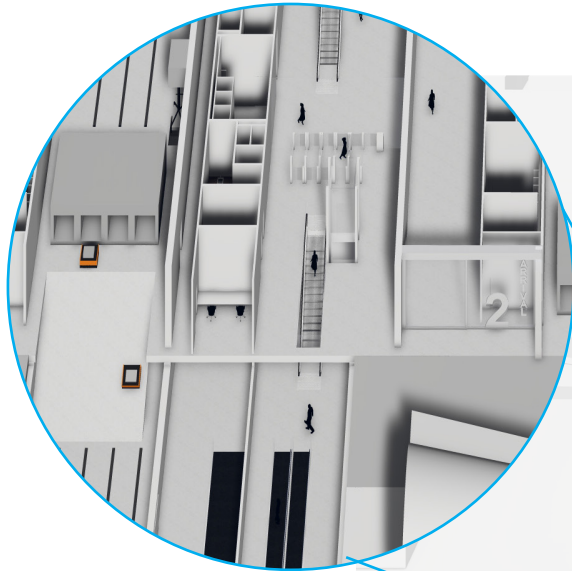

escalator to go under  
the ground



# IMPLEMENTATION

## PART B DEPARTURES



walkalators to  
the airplane



# IMPLEMENTATION

## PART B DEPARTURES



escalator to  
the airplane



# IMPLEMENTATION FLOOR PLAN C

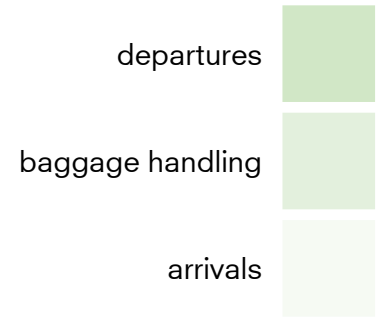
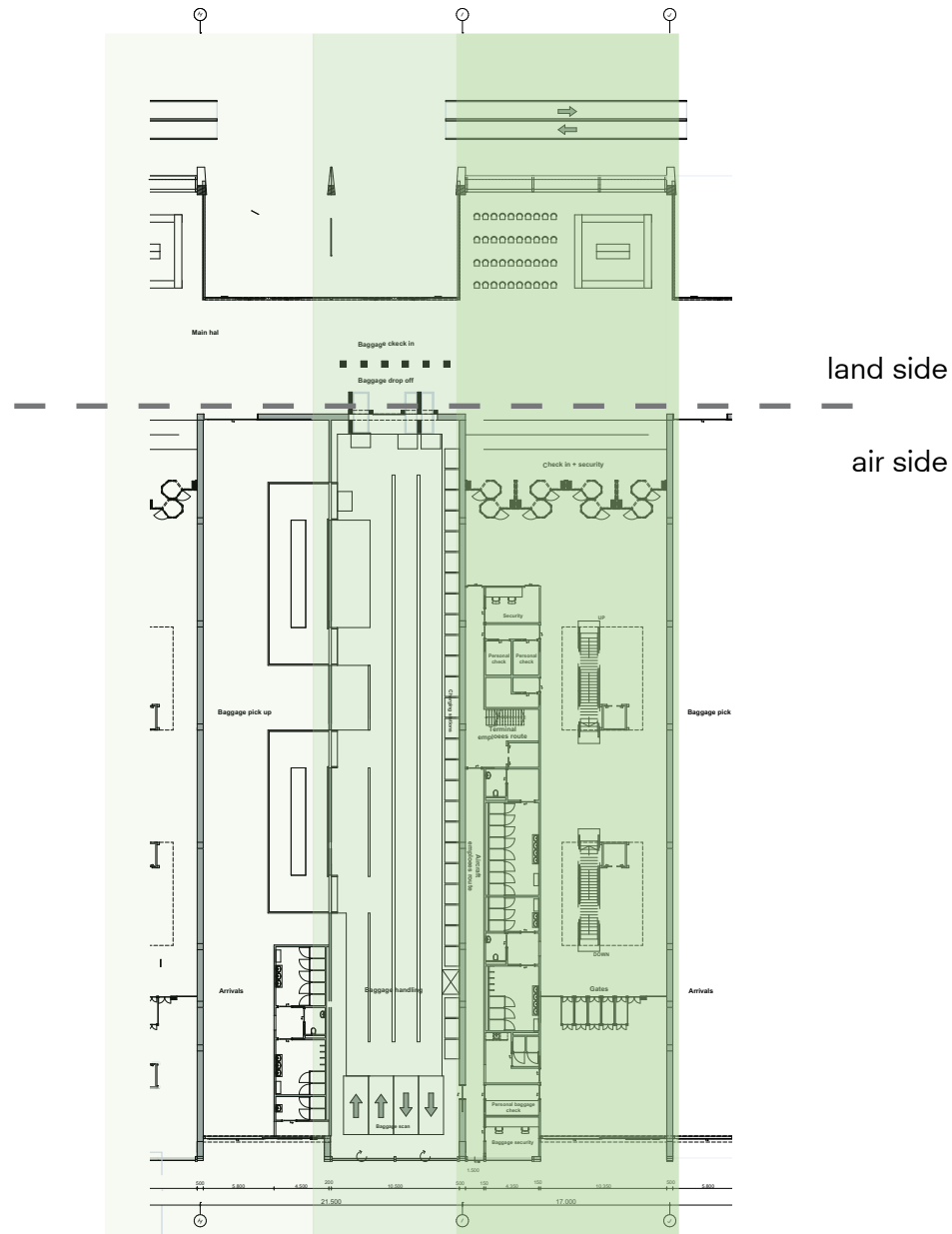

# IMPLEMENTATION

## SECTIONS PART C

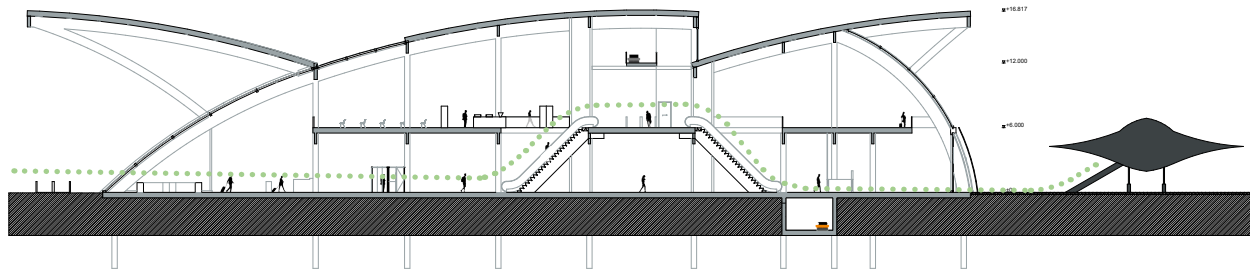
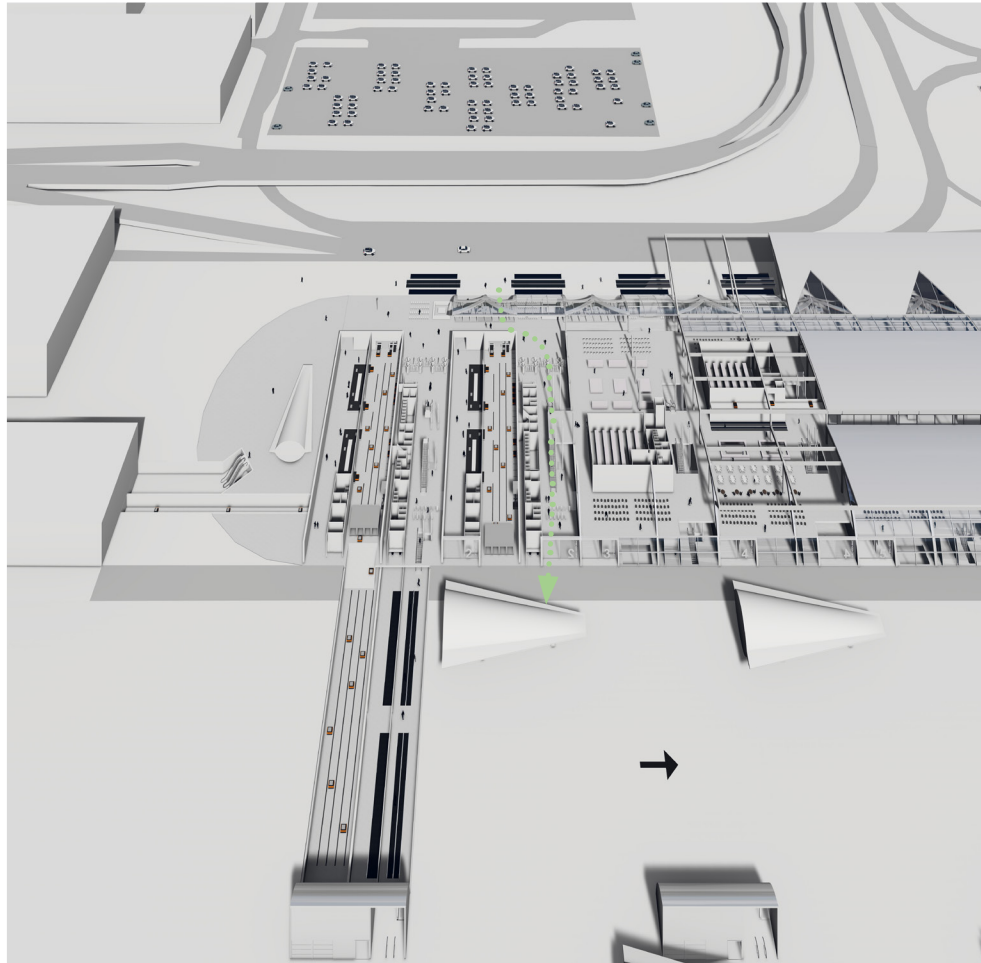

departures

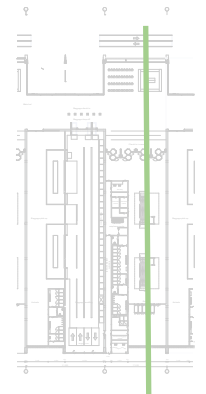

# IMPLEMENTATION SECTIONS PART C

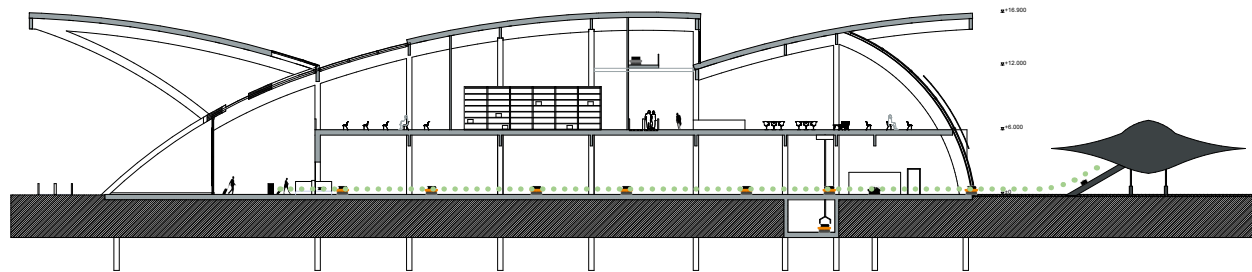
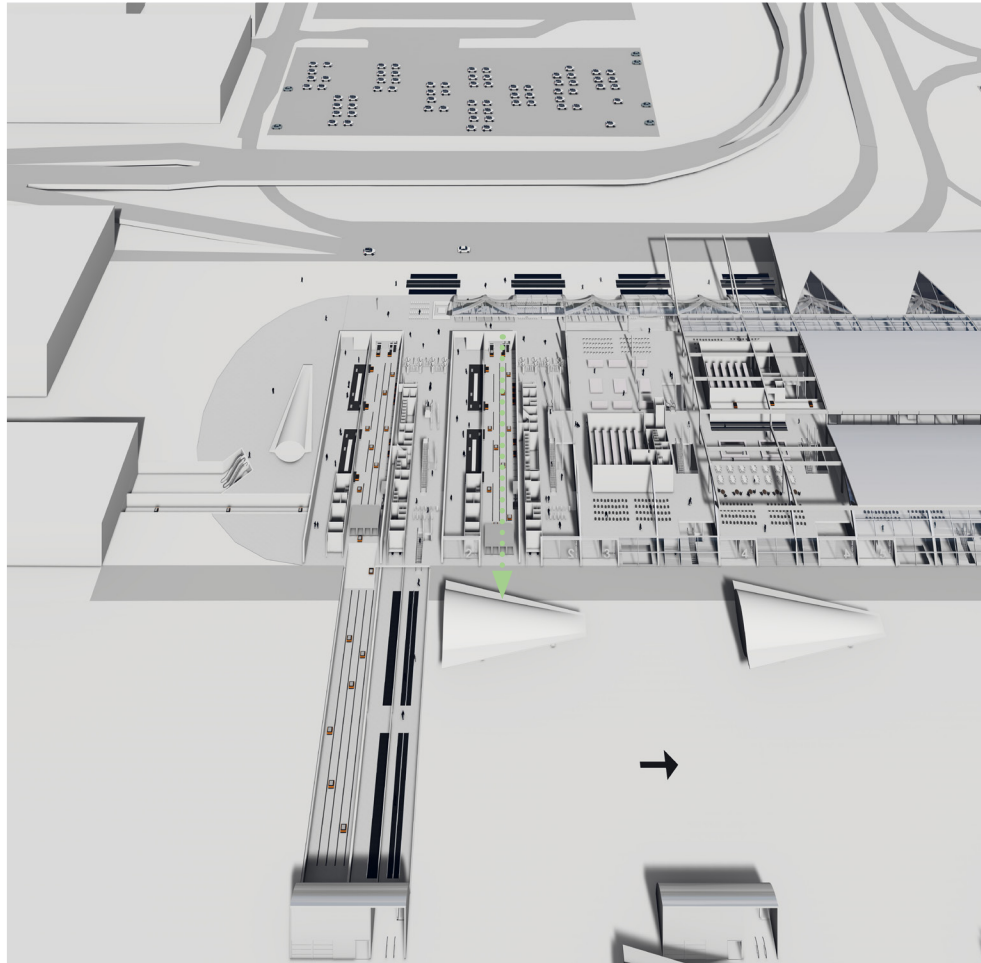

baggage handling

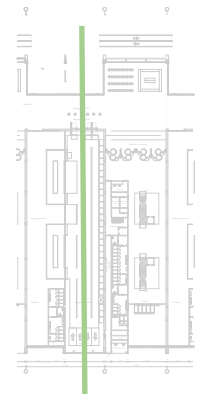



# IMPLEMENTATION

## SECTIONS PART C

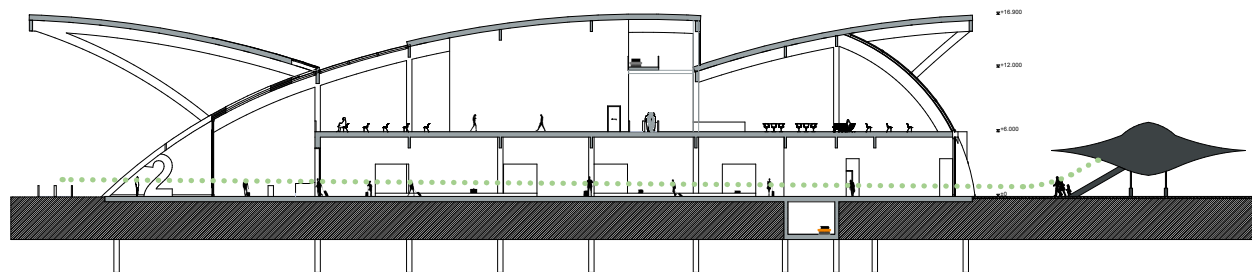
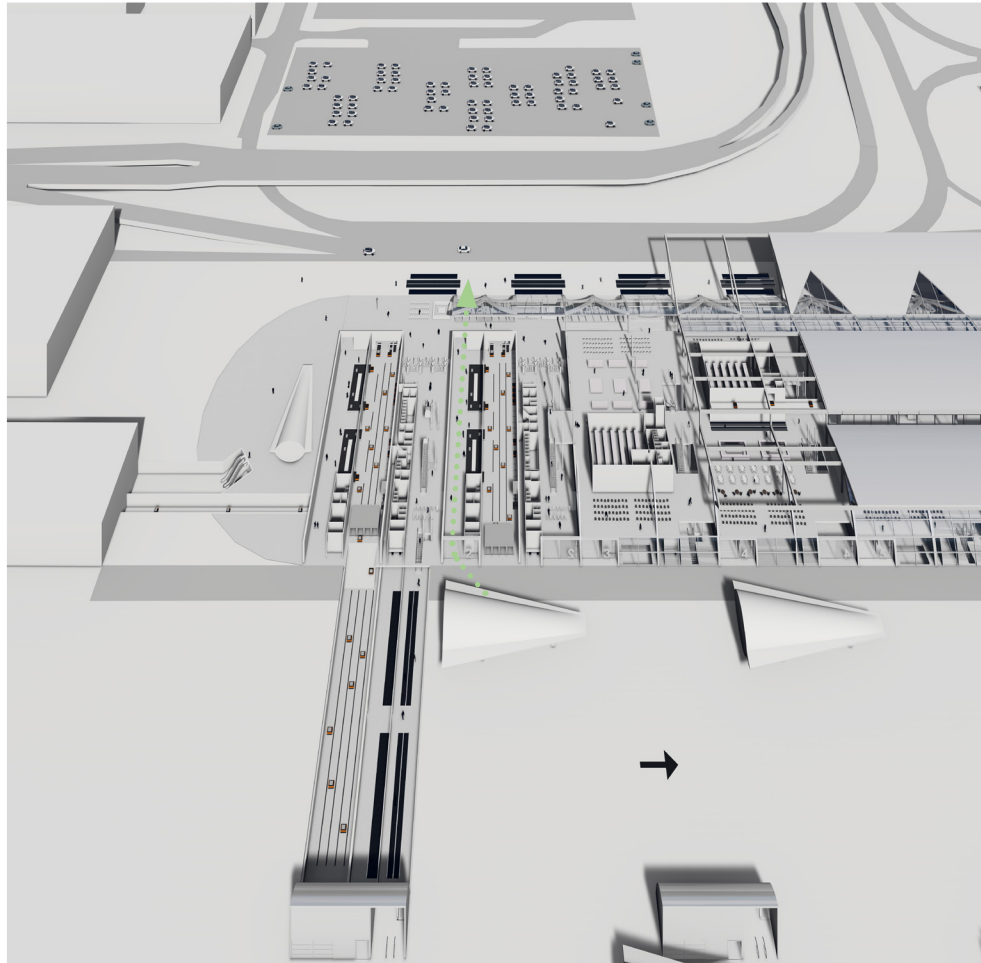

arrivals

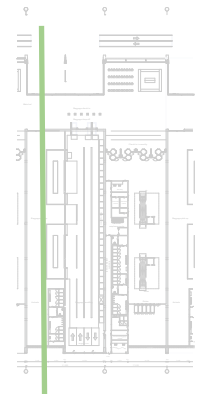

# IMPLEMENTATION KEY SPACE

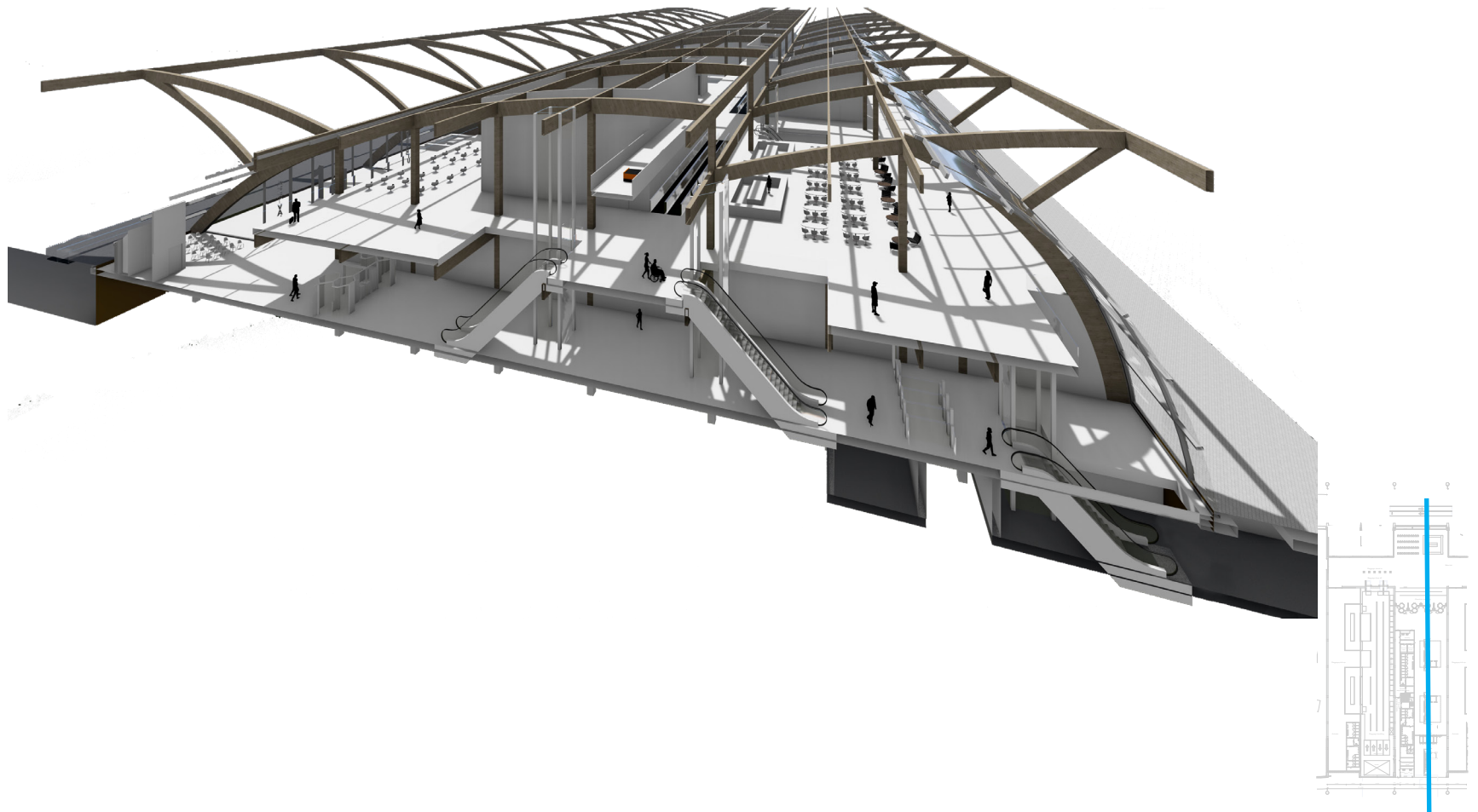

# IMPLEMENTATION FLOOR PLAN D

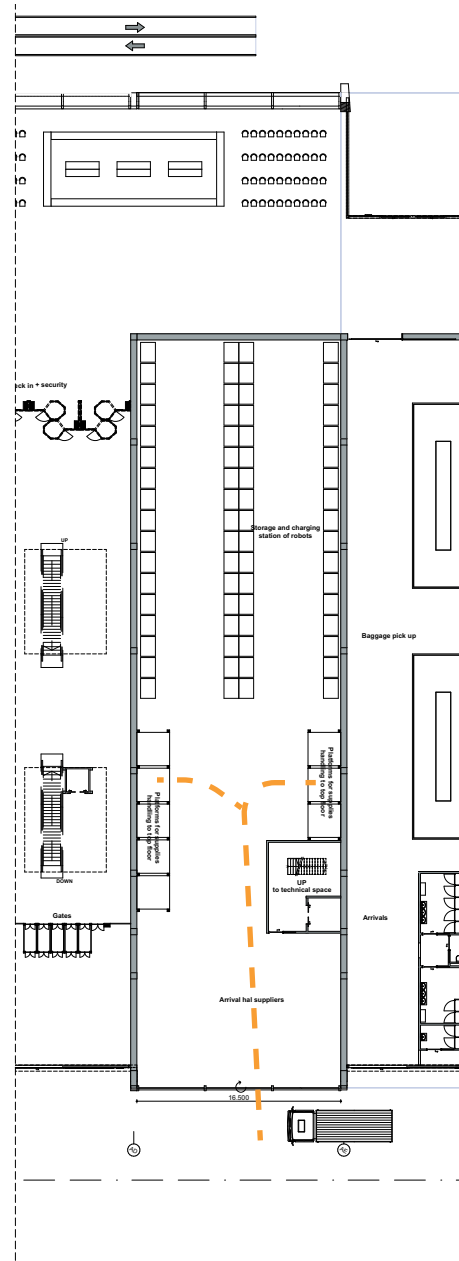

# IMPLEMENTATION FLOOR PLAN D

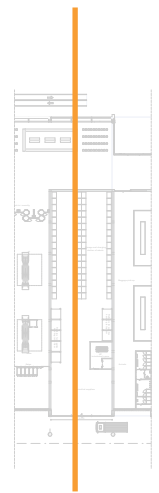
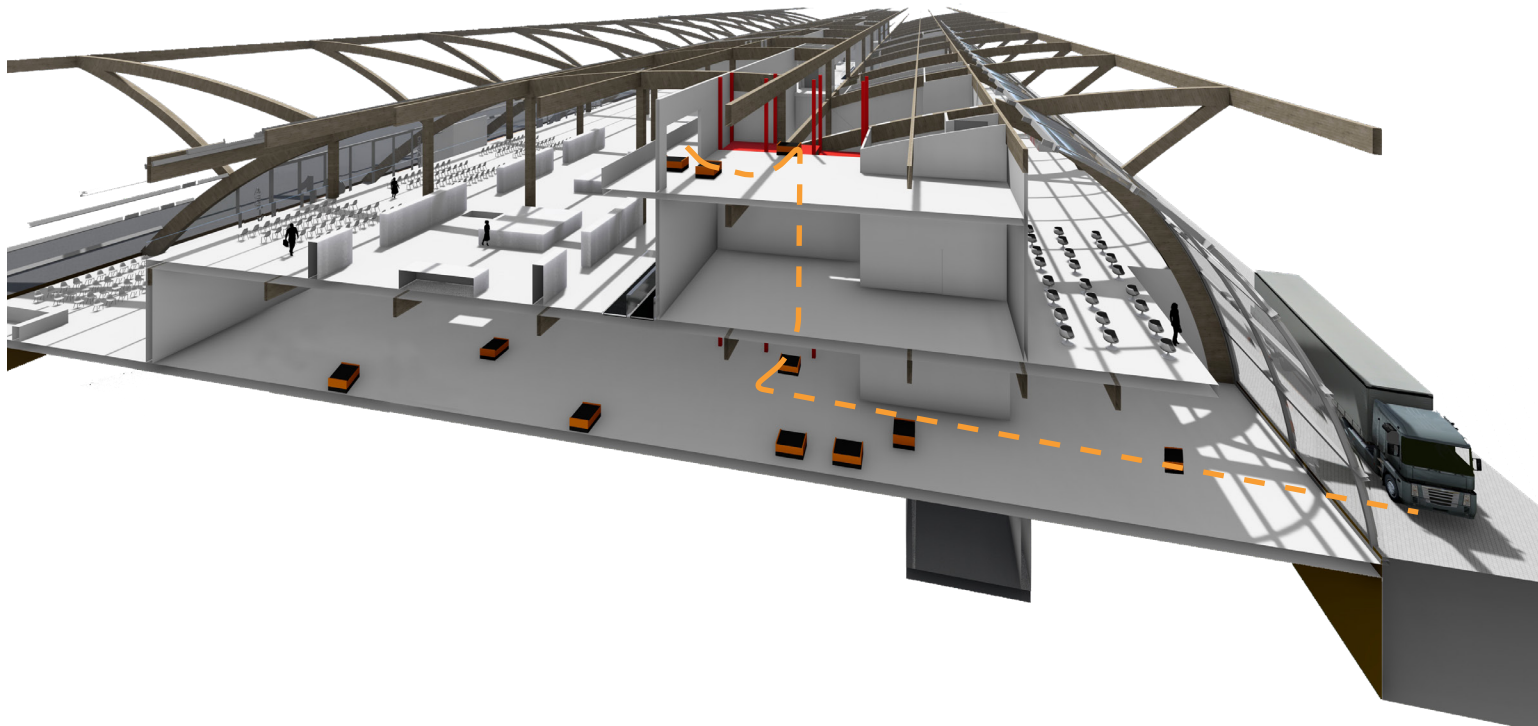

# IMPLEMENTATION FLOOR PLAN D

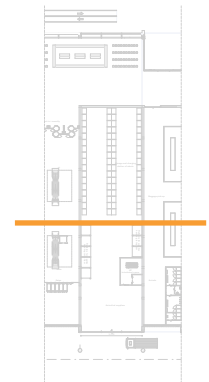
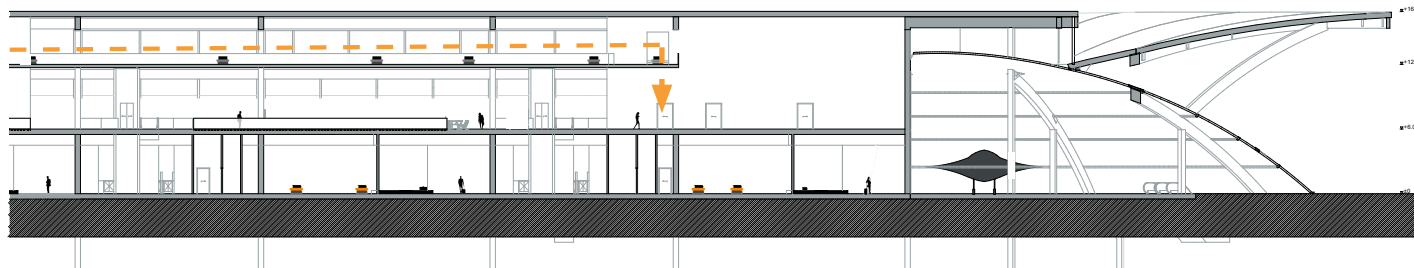
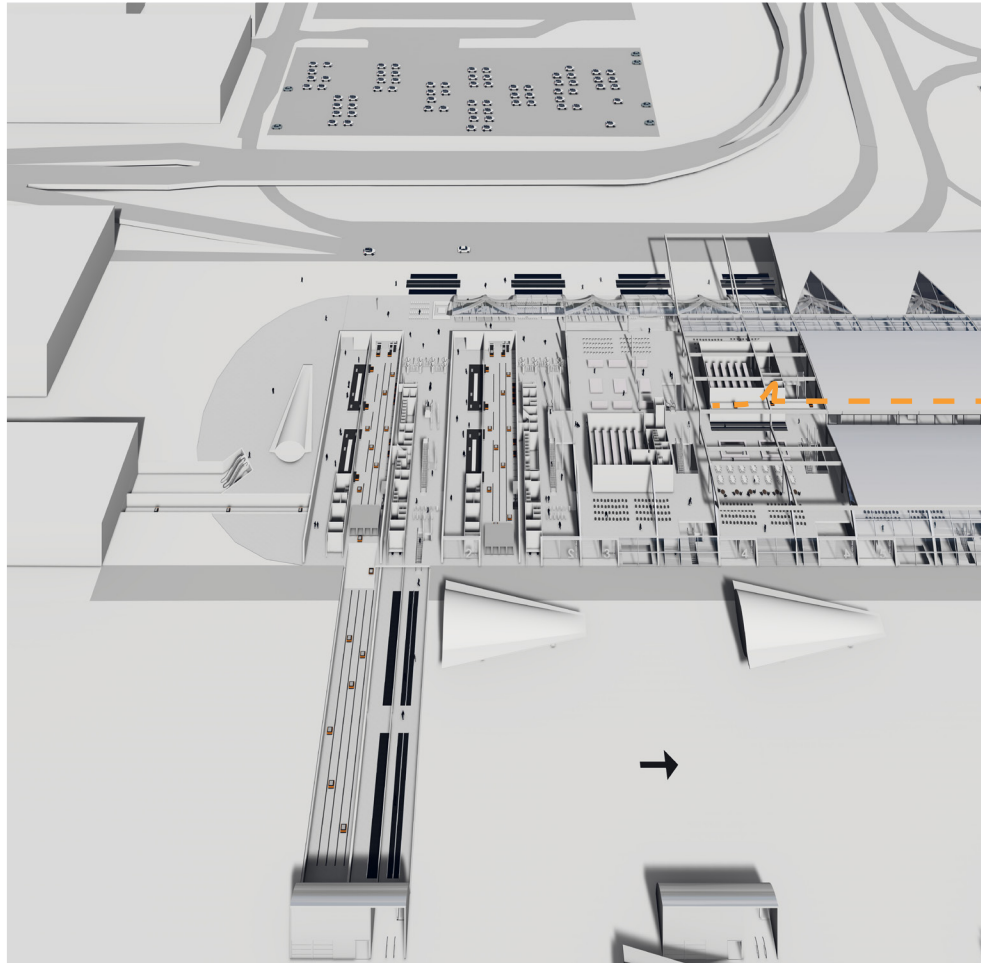

# IMPLEMENTATION EXPERIENCE



# IMPLEMENTATION EXPERIENCE

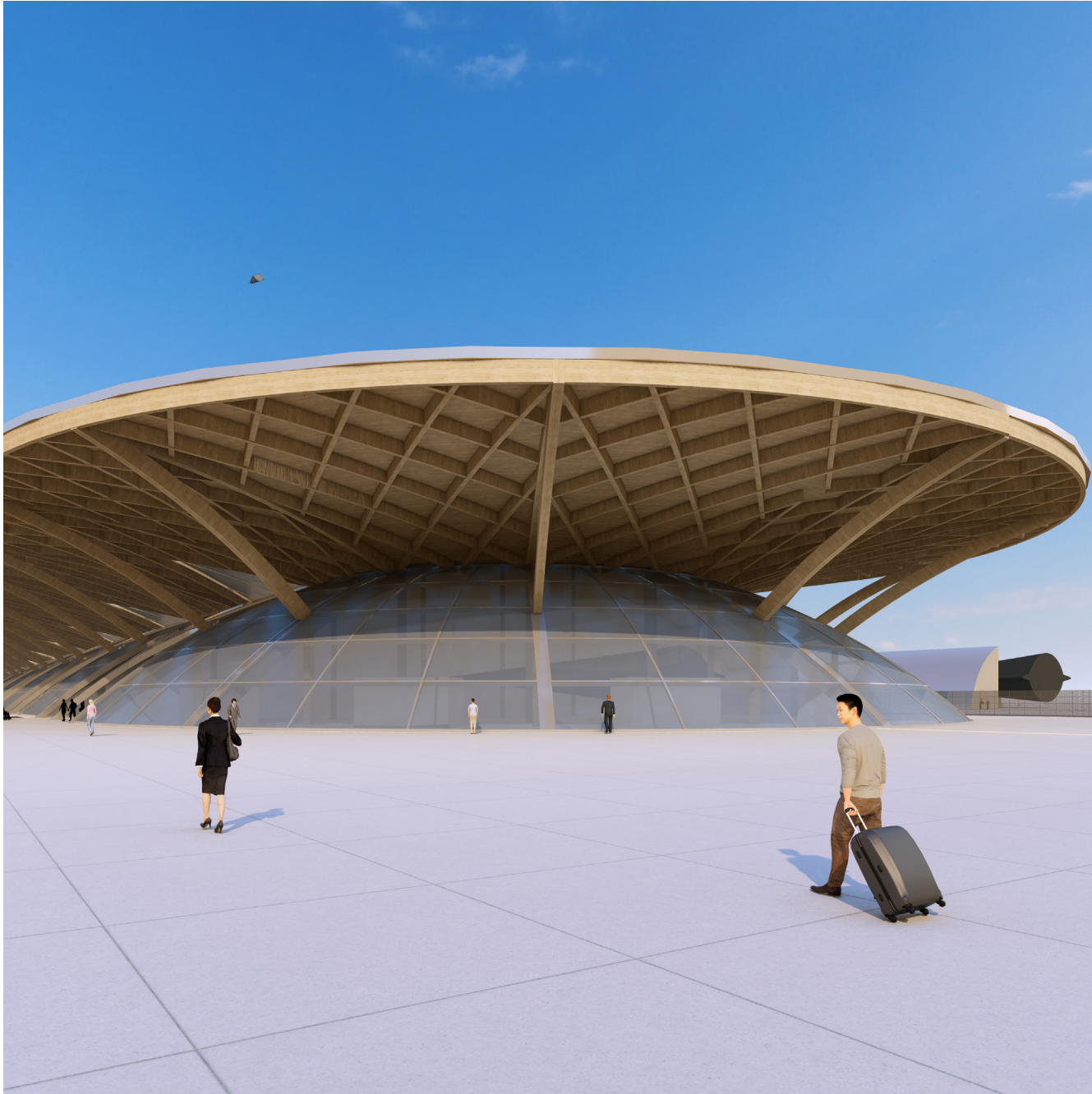

# IMPLEMENTATION EXPERIENCE

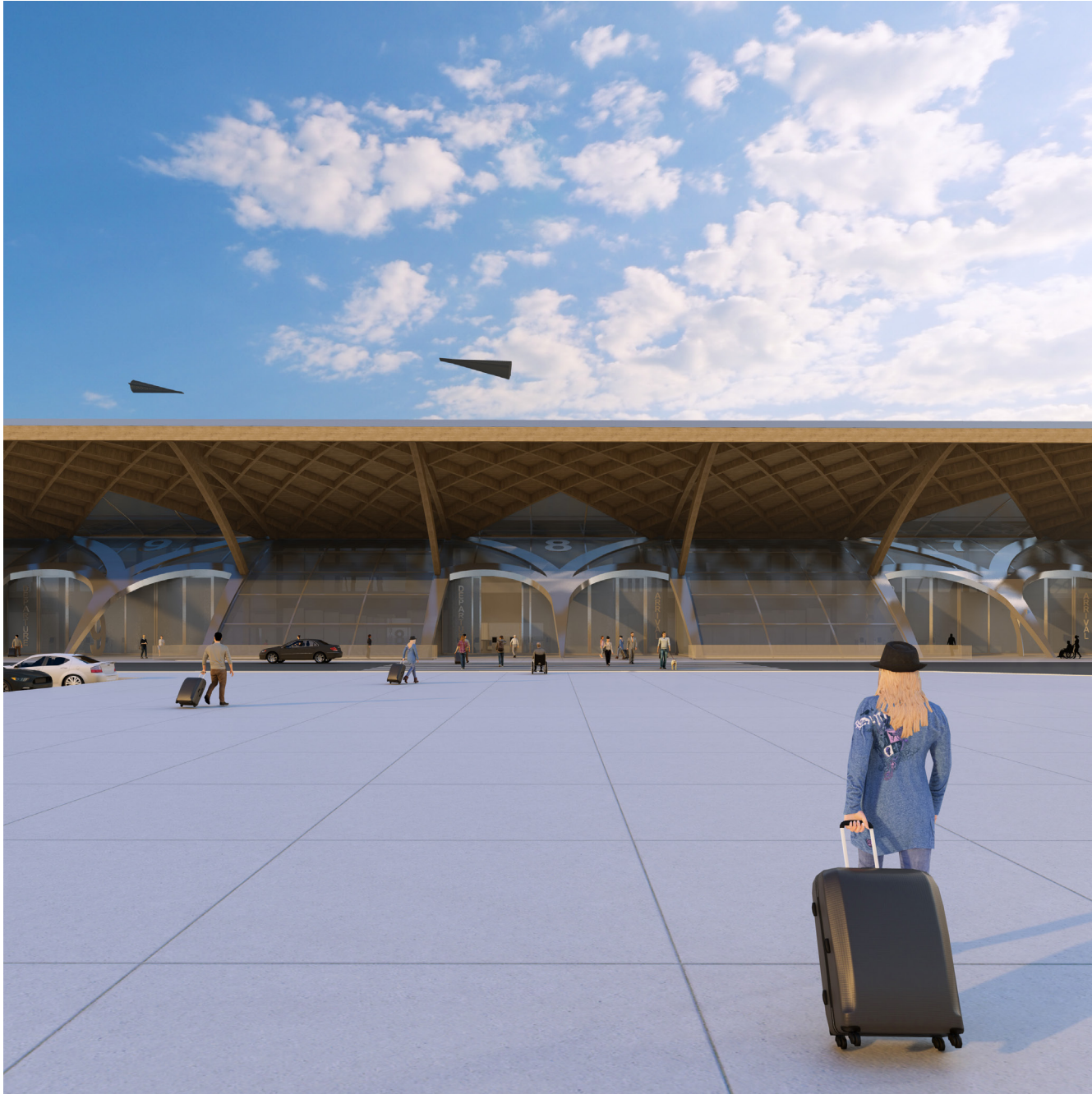



# IMPLEMENTATION EXPERIENCE

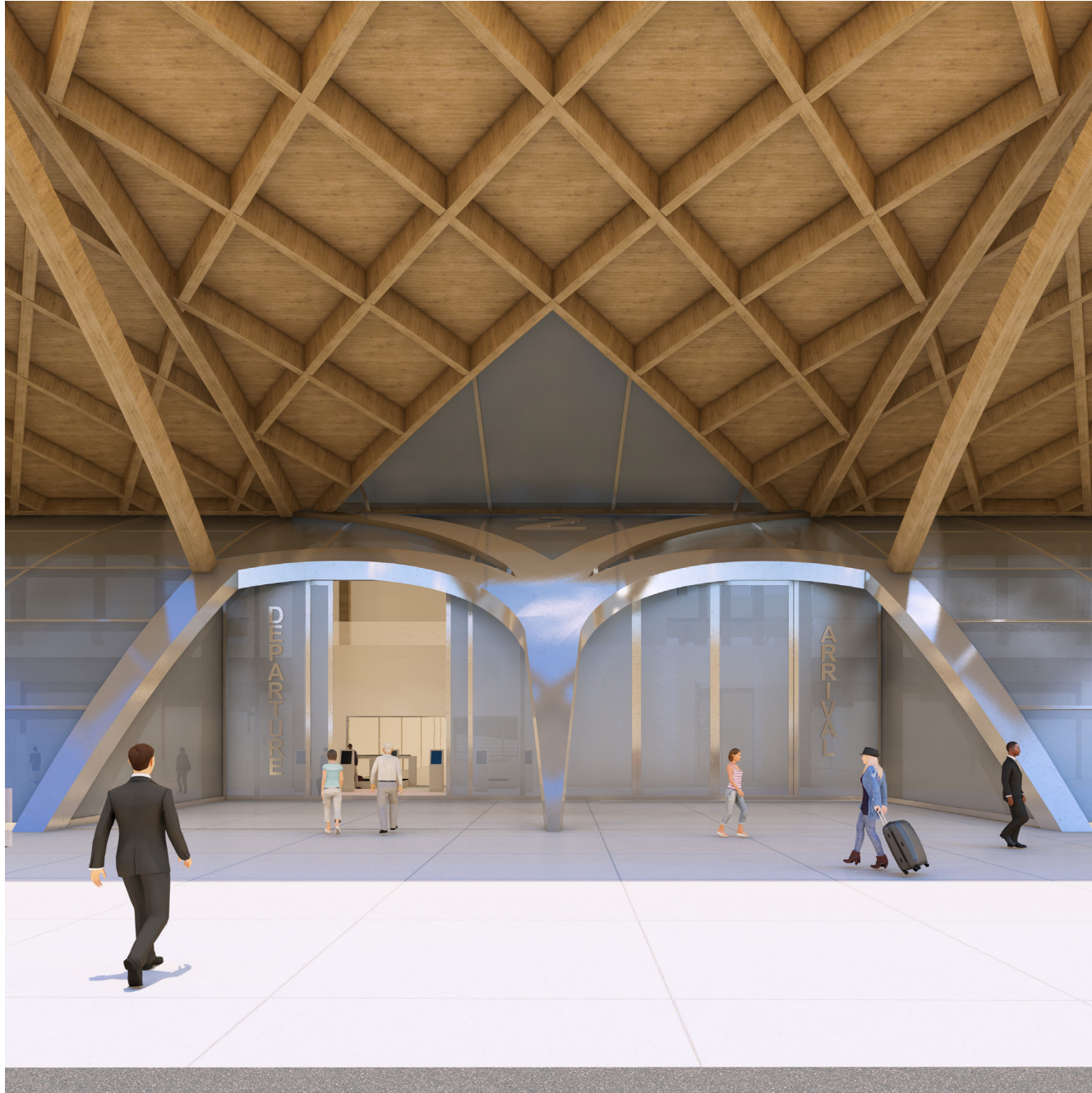

# IMPLEMENTATION EXPERIENCE



# IMPLEMENTATION EXPERIENCE



lumion

# IMPLEMENTATION EXPERIENCE



# IMPLEMENTATION EXPERIENCE

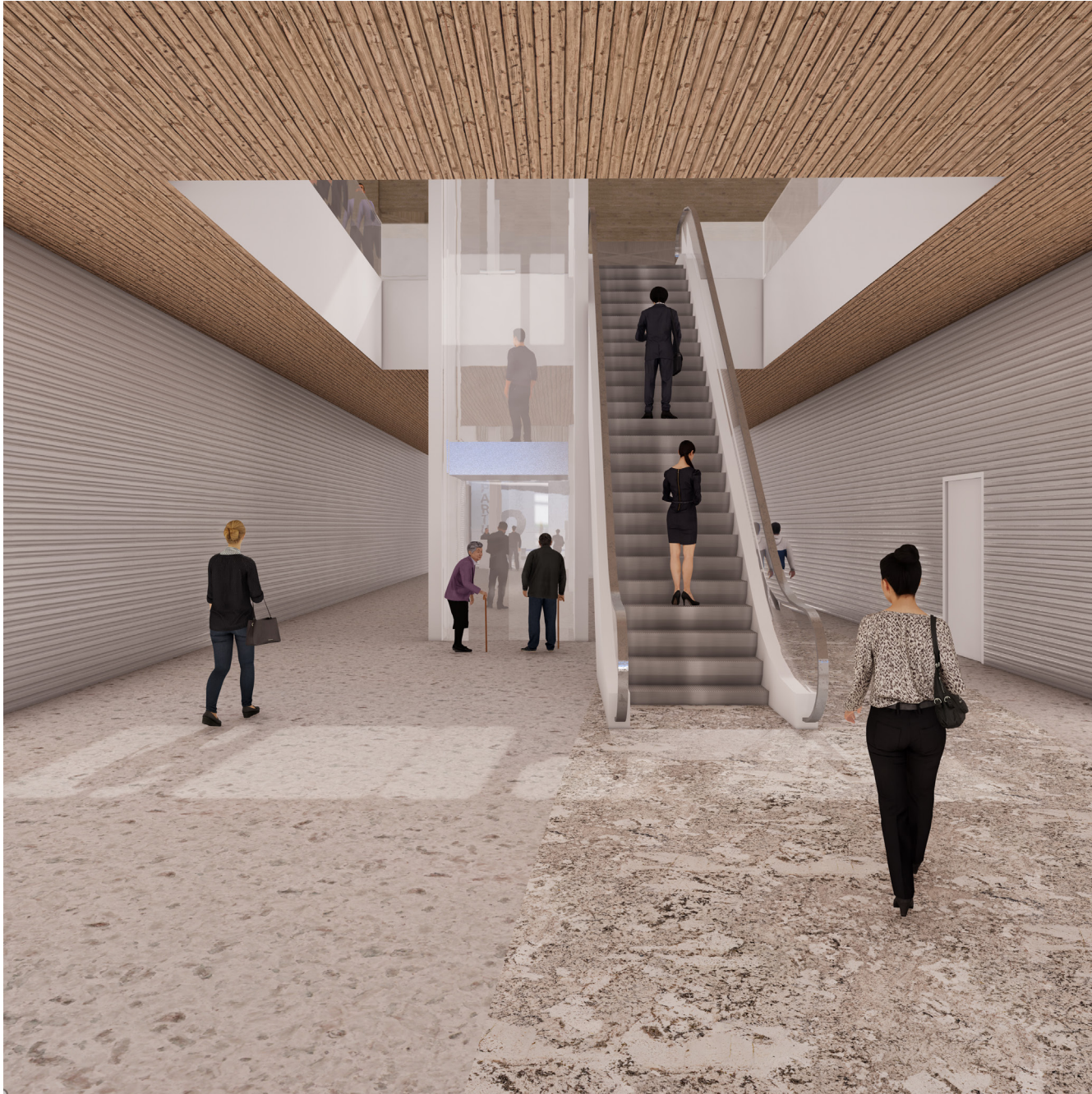

# IMPLEMENTATION EXPERIENCE



# IMPLEMENTATION EXPERIENCE



# IMPLEMENTATION EXPERIENCE

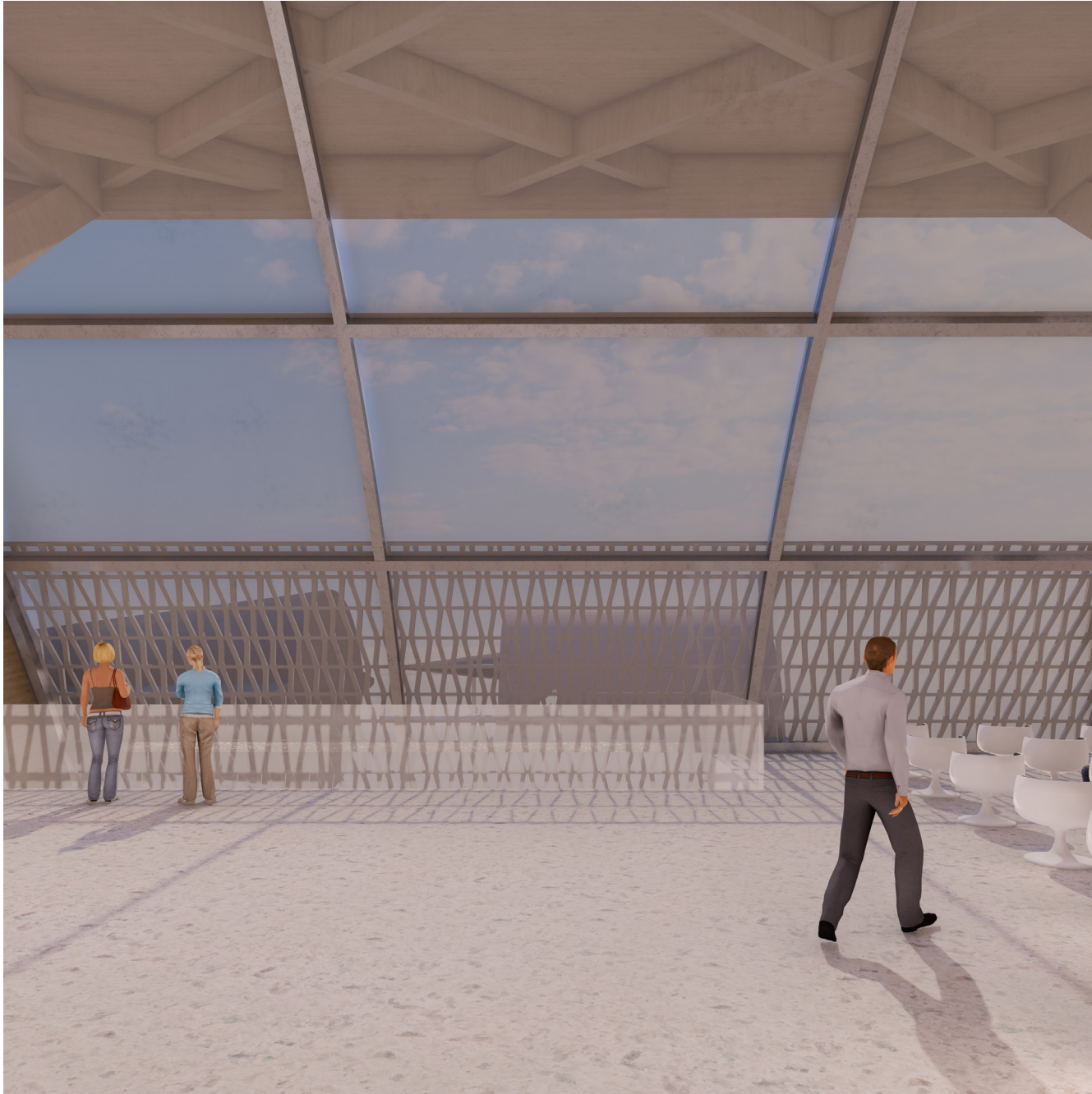



# IMPLEMENTATION EXPERIENCE



# IMPLEMENTATION EXPERIENCE

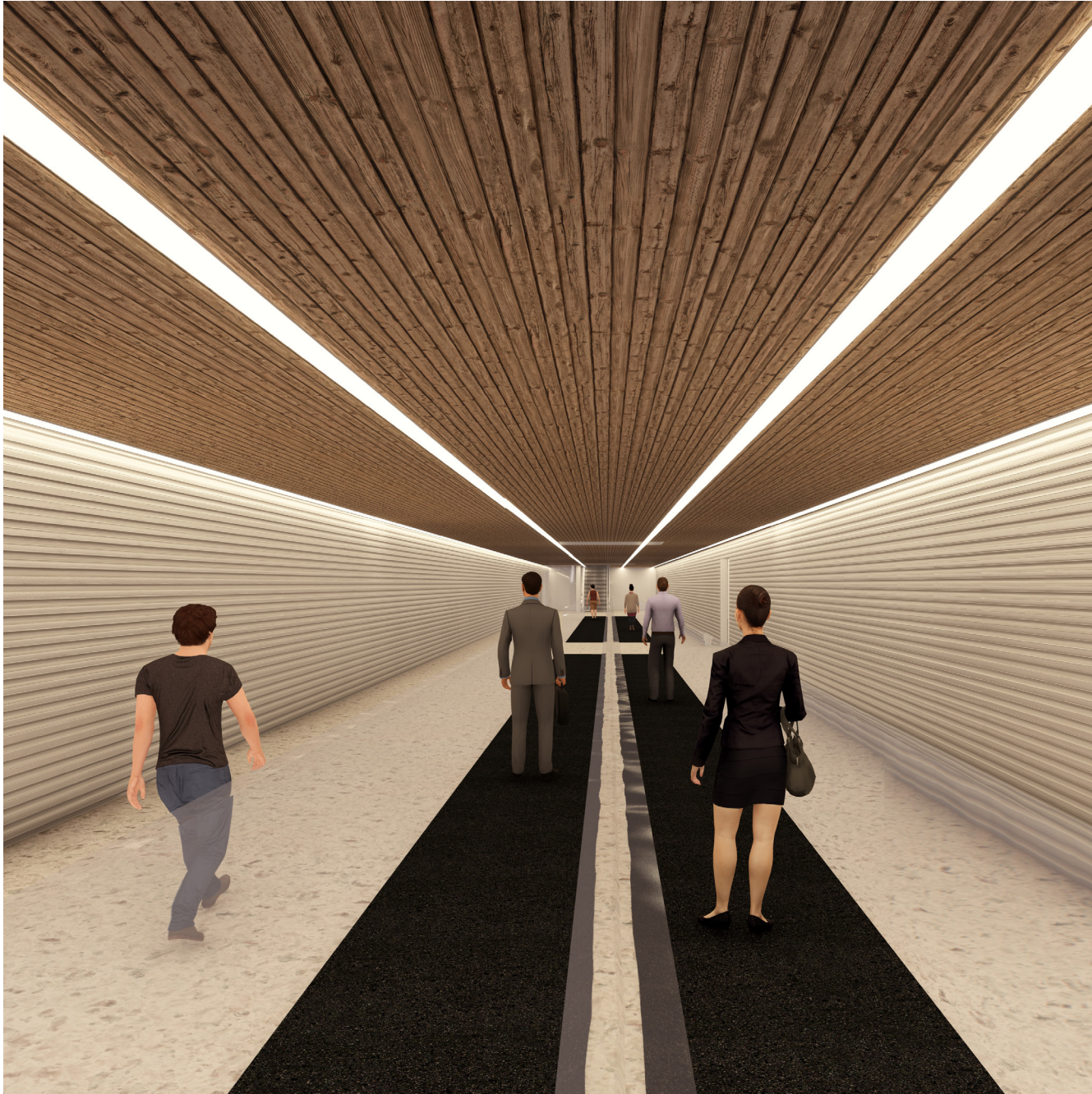

# IMPLEMENTATION EXPERIENCE

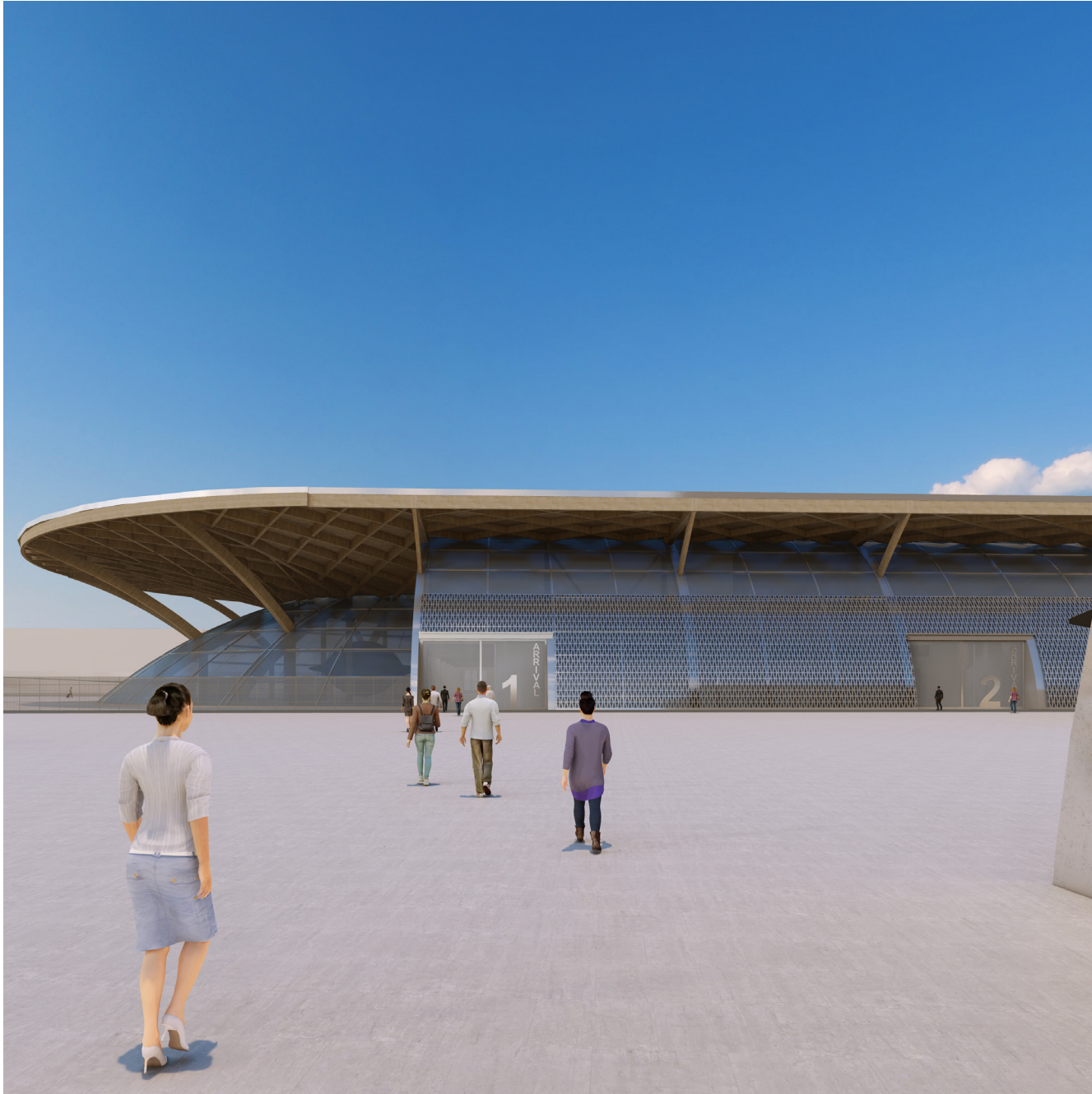

01 INTRODUCTION

02 RESEARCH

& DESIGN BRIEF

03 CONCEPT

04 IMPLEMENTATION

**05 DEVELOPMENT**

06 CONCLUSION

# DEVELOPMENT STRUCTURE

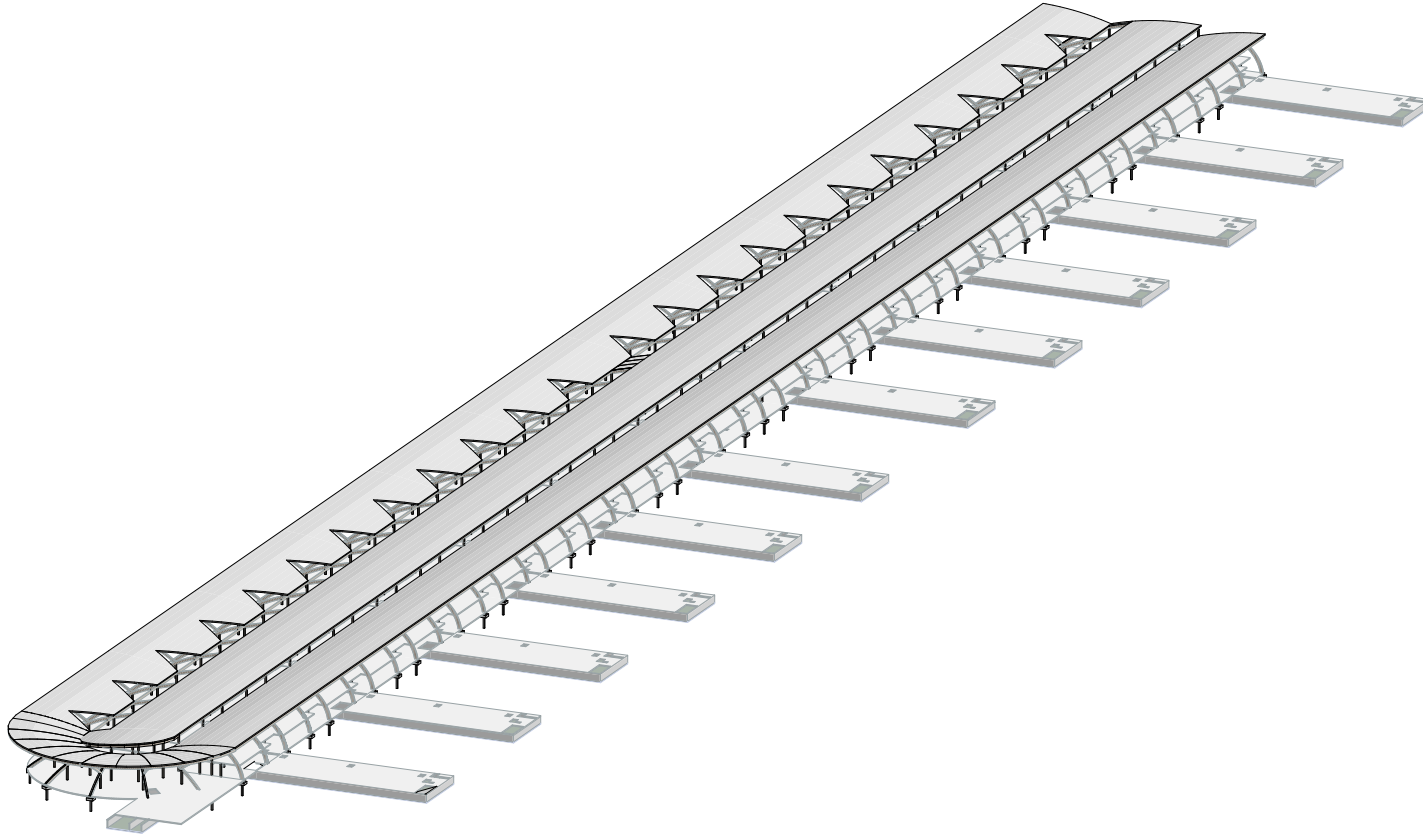

# DEVELOPMENT STRUCTURE

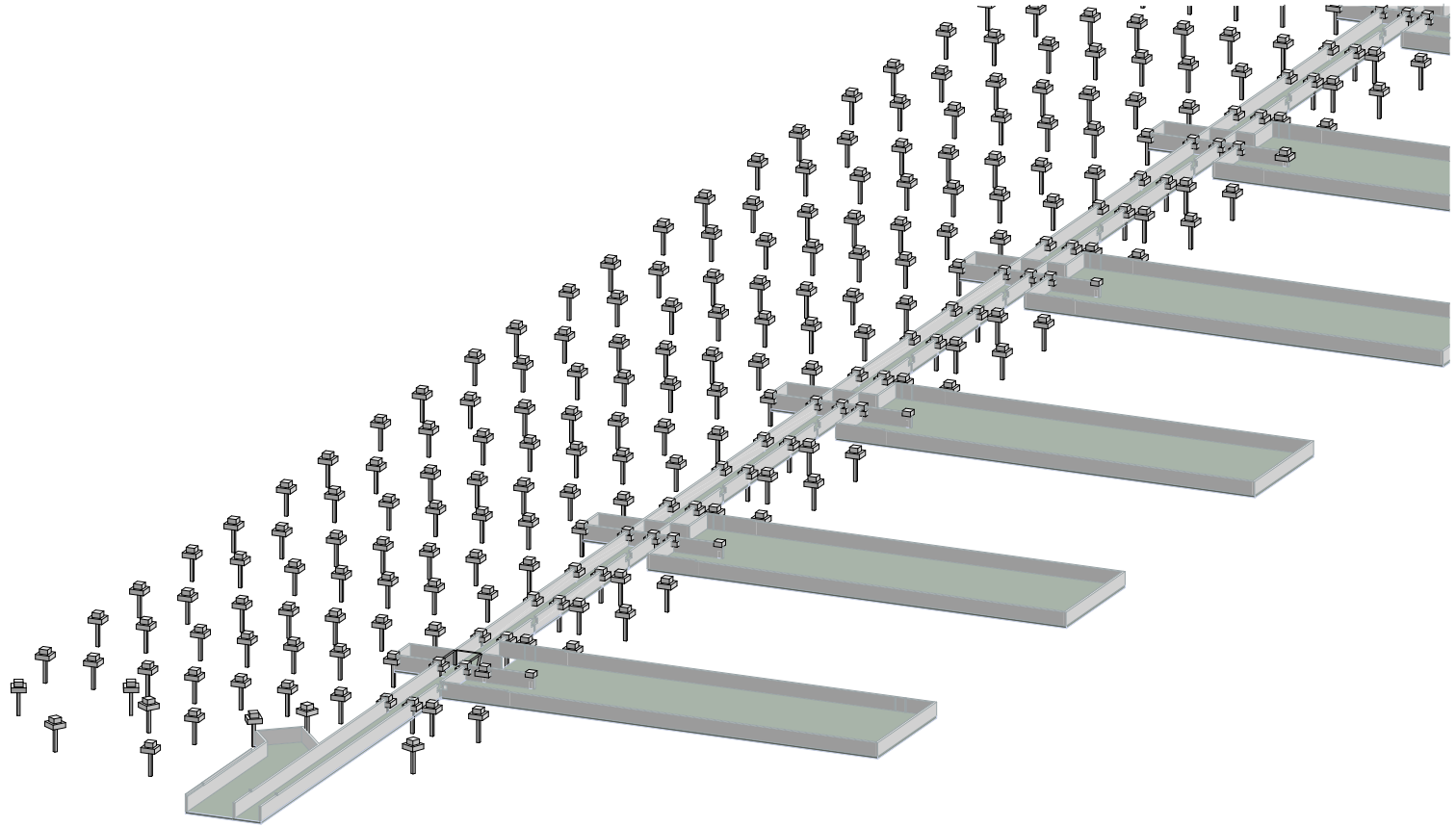

# DEVELOPMENT STRUCTURE

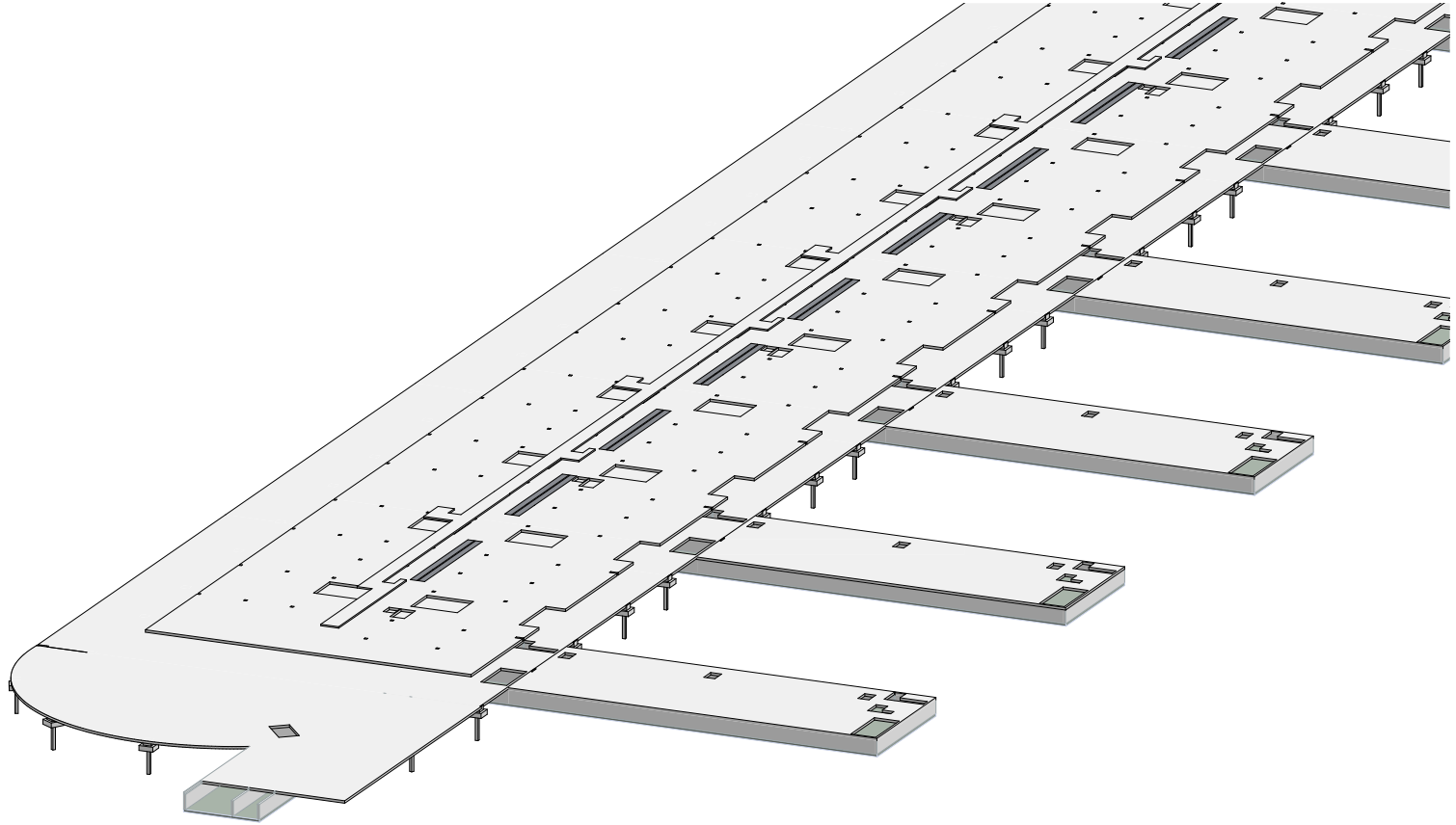

# DEVELOPMENT STRUCTURE

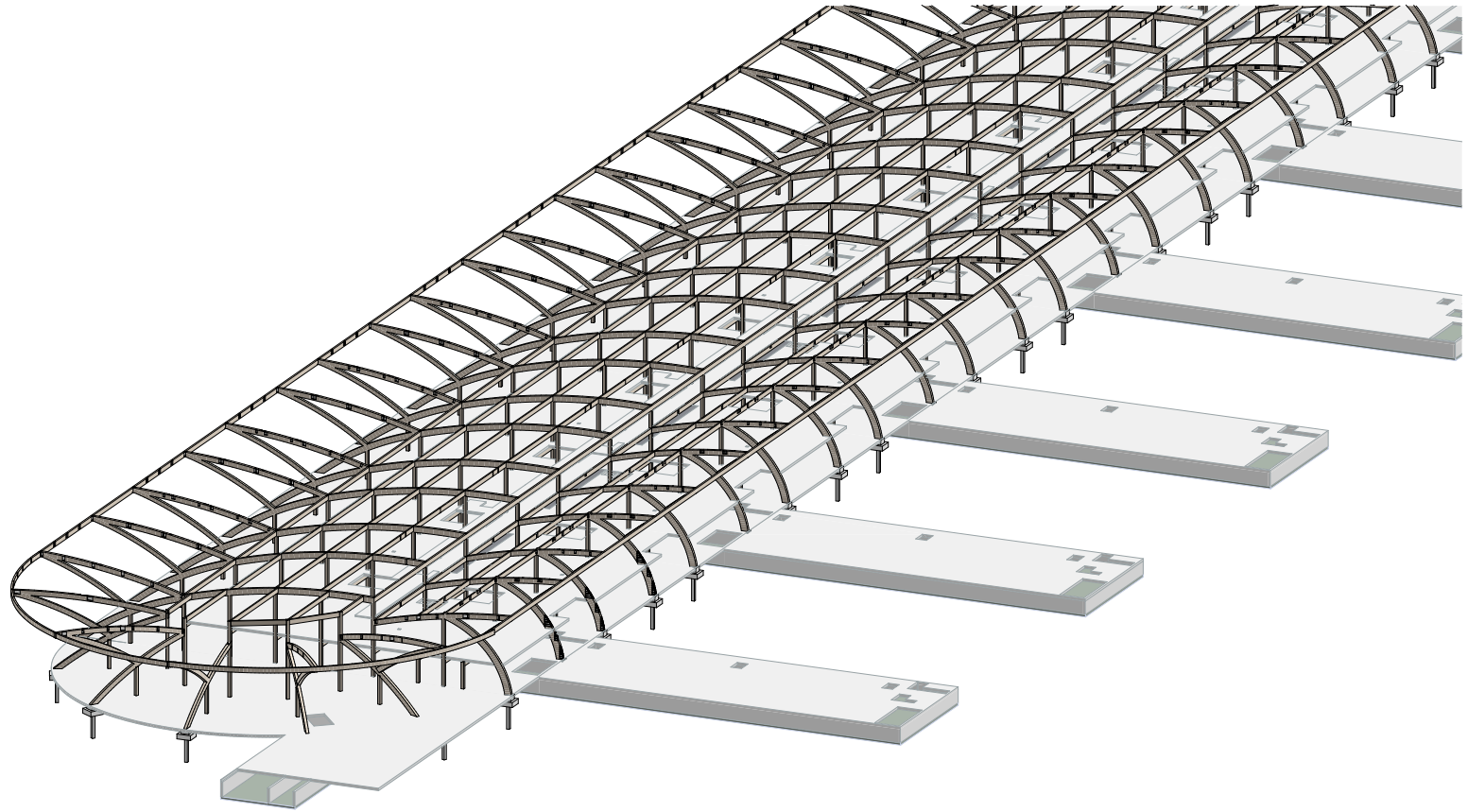



# DEVELOPMENT STRUCTURE

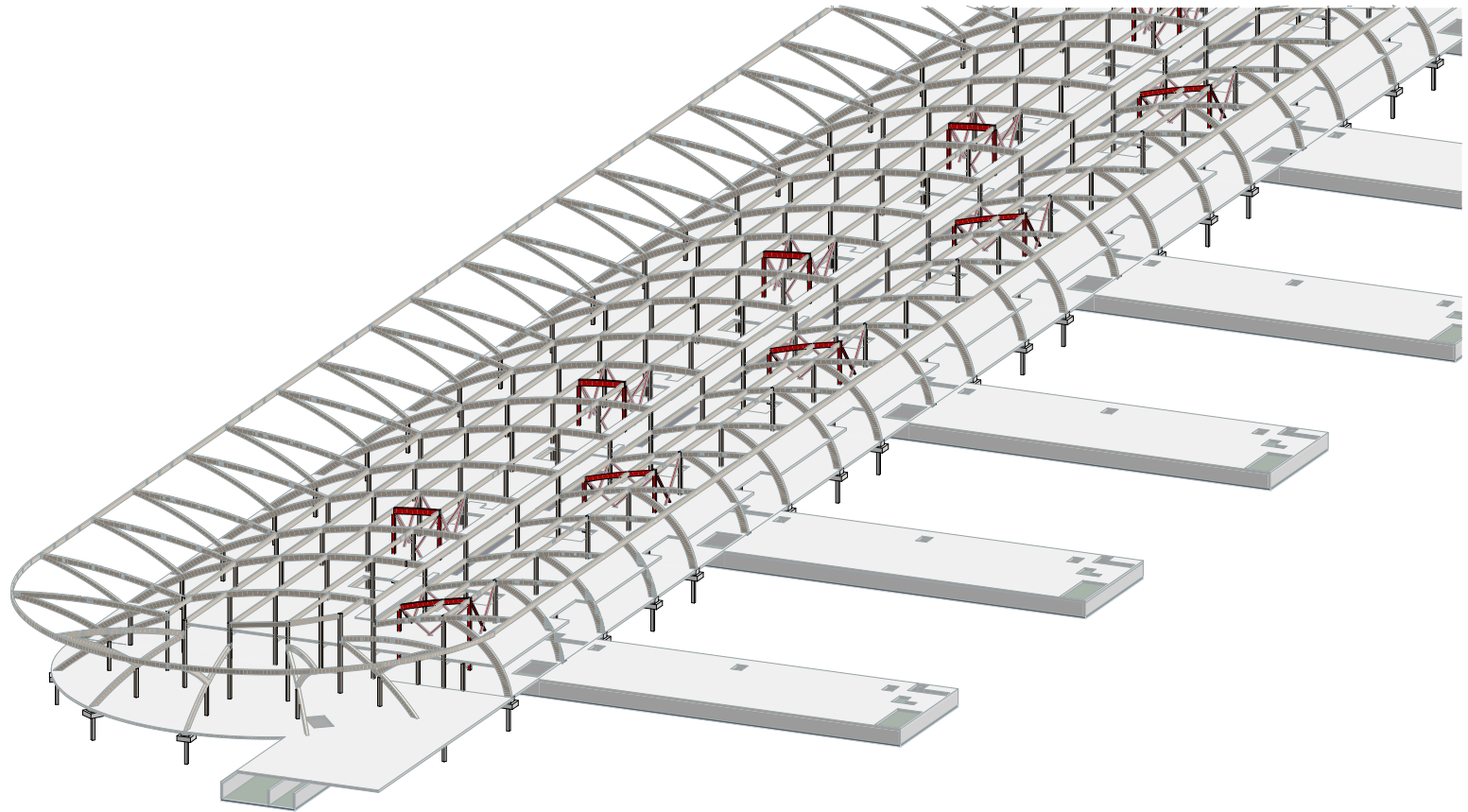

# DEVELOPMENT STRUCTURE

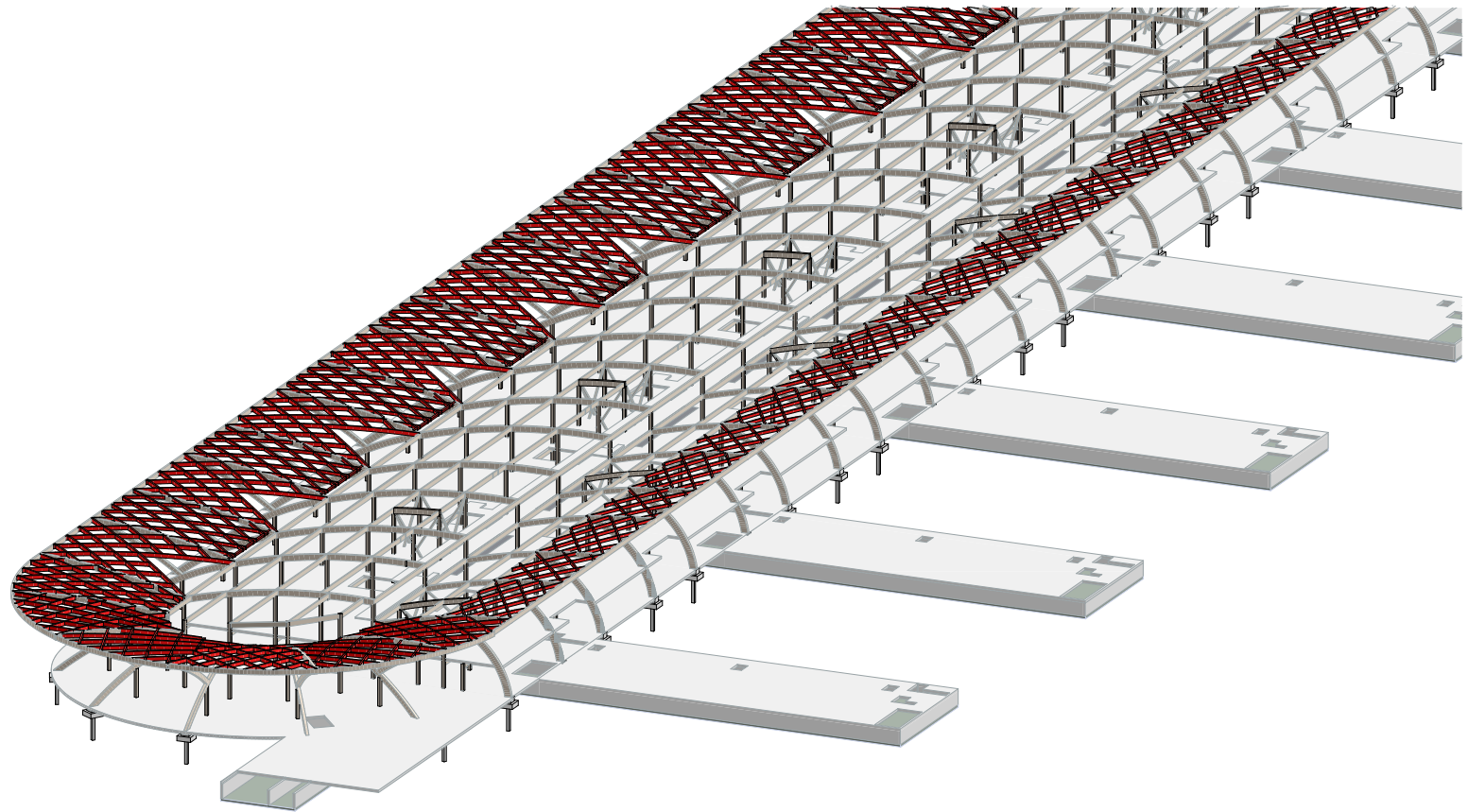

# DEVELOPMENT STRUCTURE

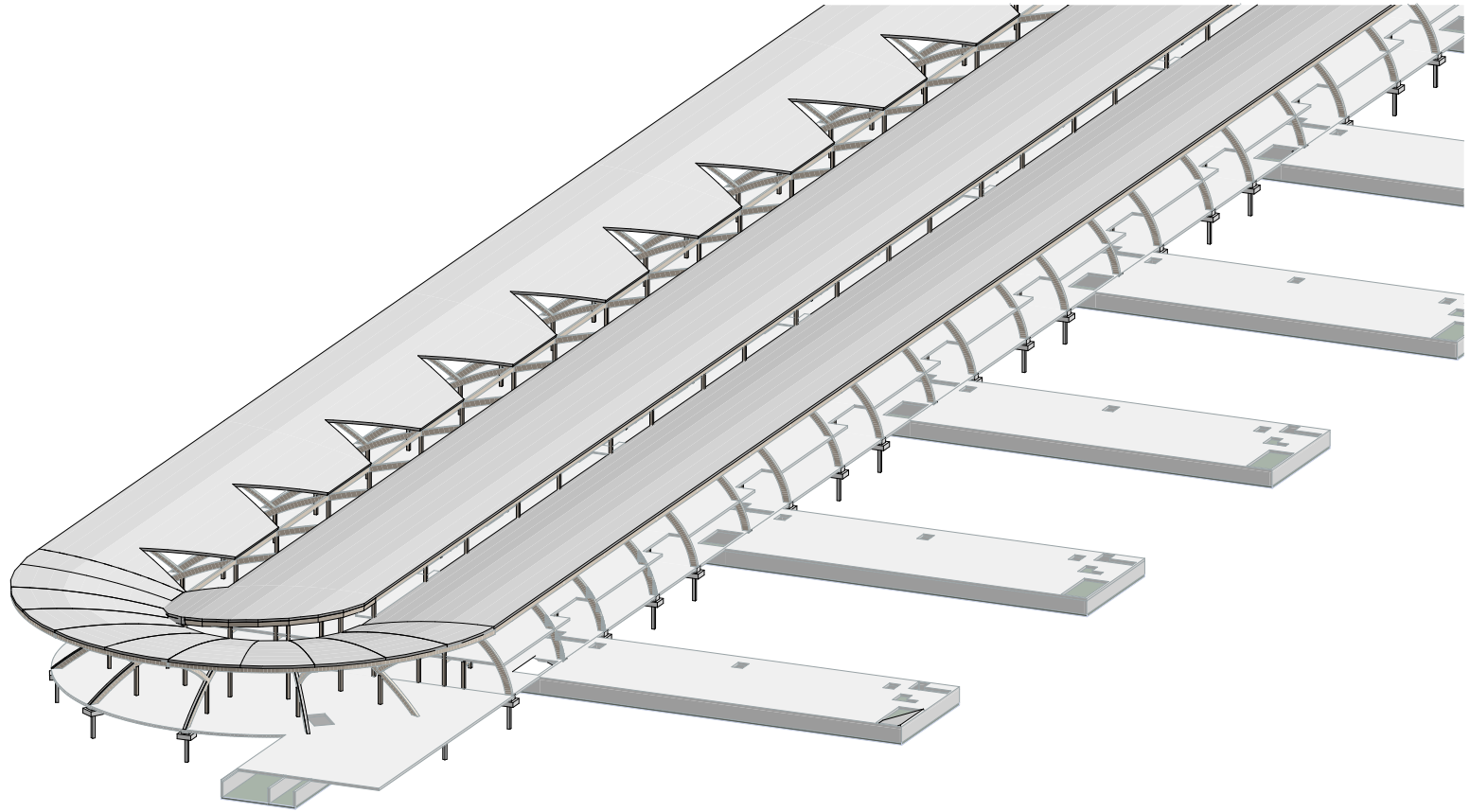

# DEVELOPMENT CLIMATE

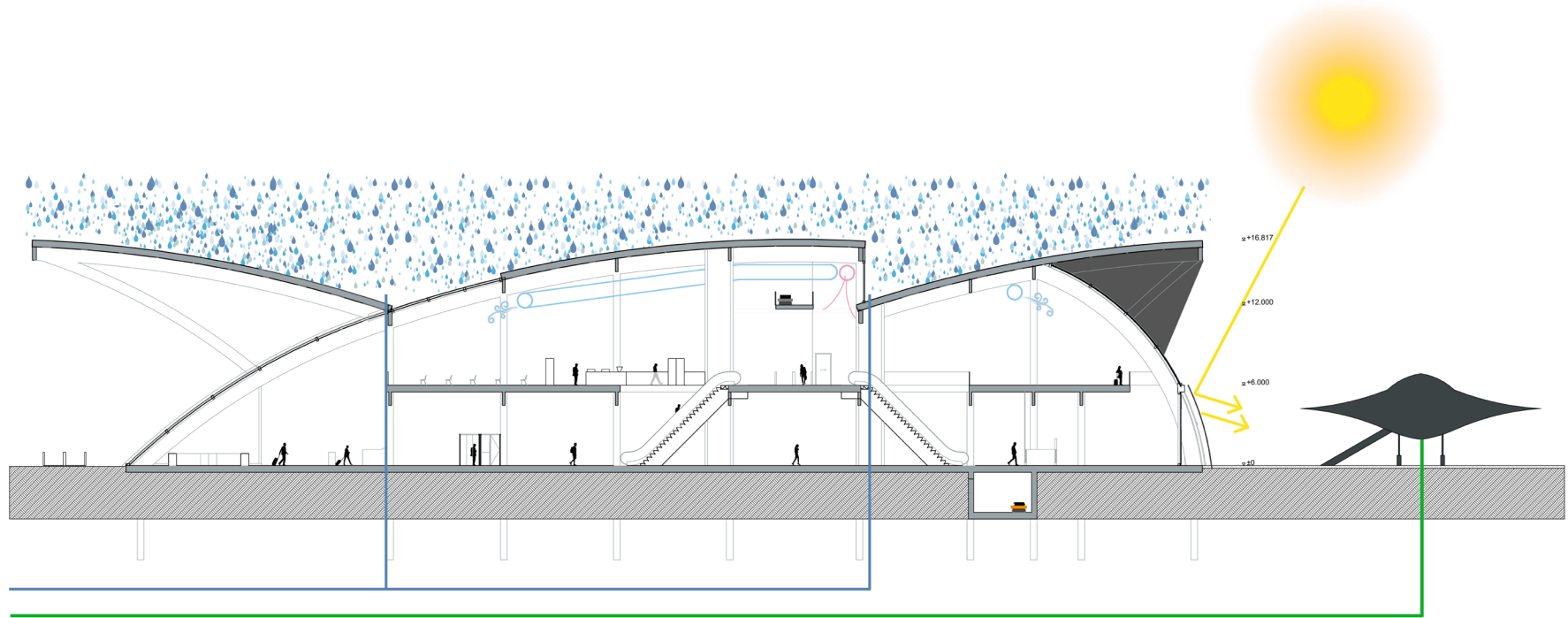

DEVELOPMENT

# MATERIAL REQUIREMENTS



**Sustainable**

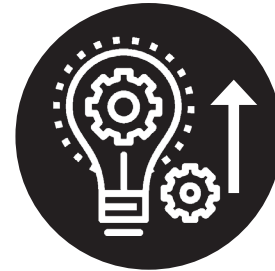

**Representative**



**Low maintenance**

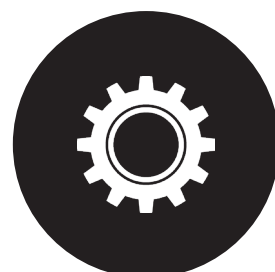

**Functional**

DEVELOPMENT  
**CHOSEN MATERIALS**



**Glulam**

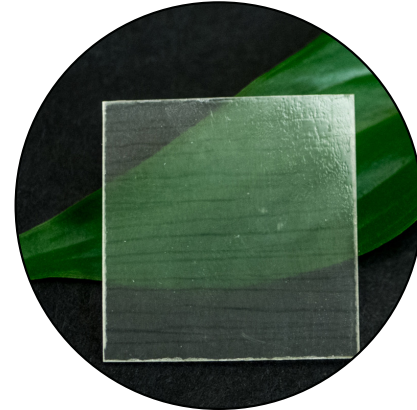

**Transparent wood**



**Anodized aluminium**

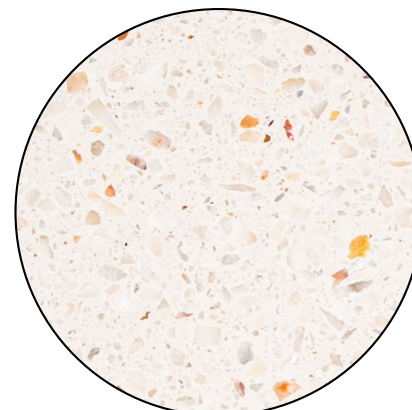

**Terrazzo**

# DEVELOPMENT MATERIALS APPLIED

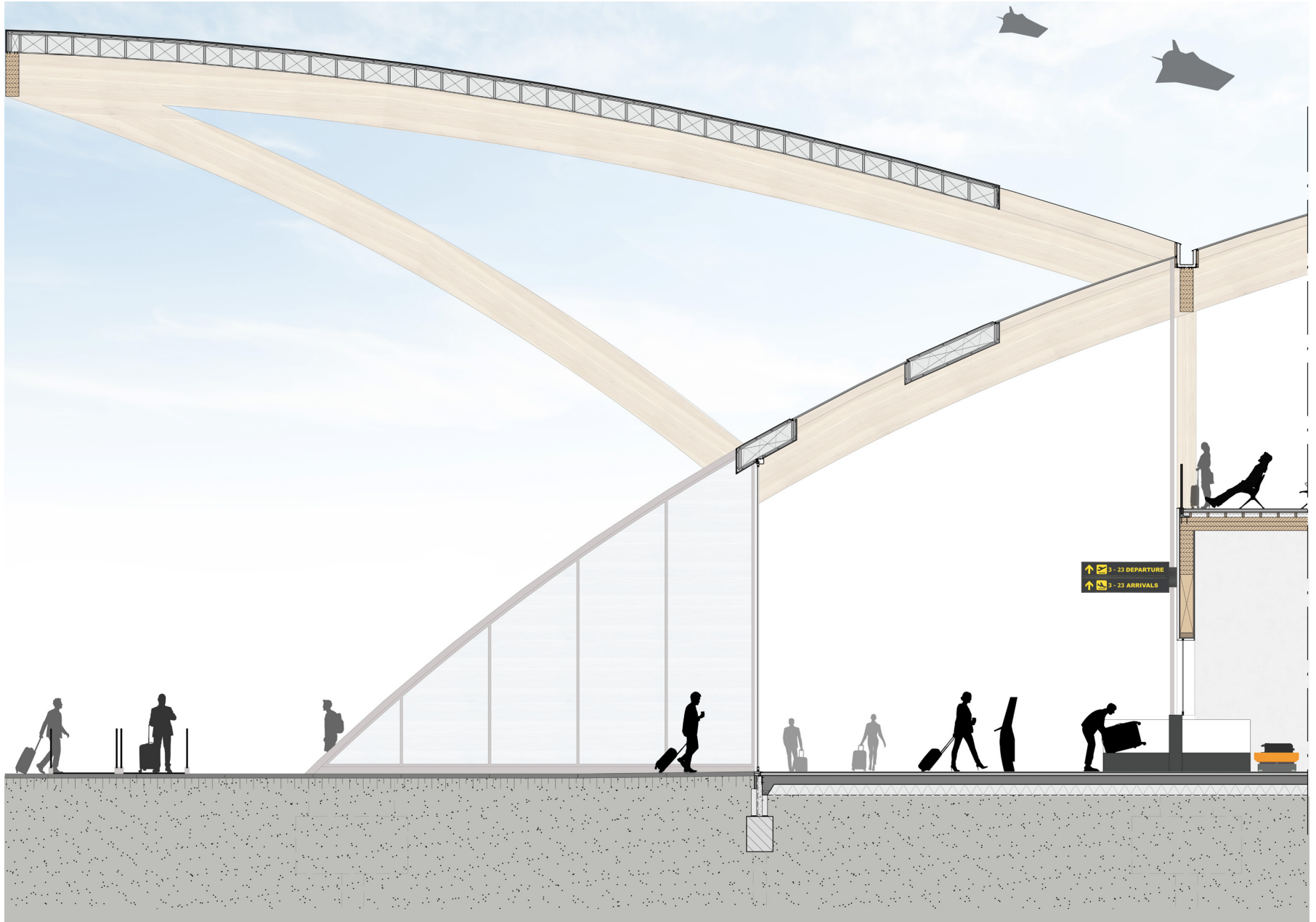

# DEVELOPMENT DETAILS

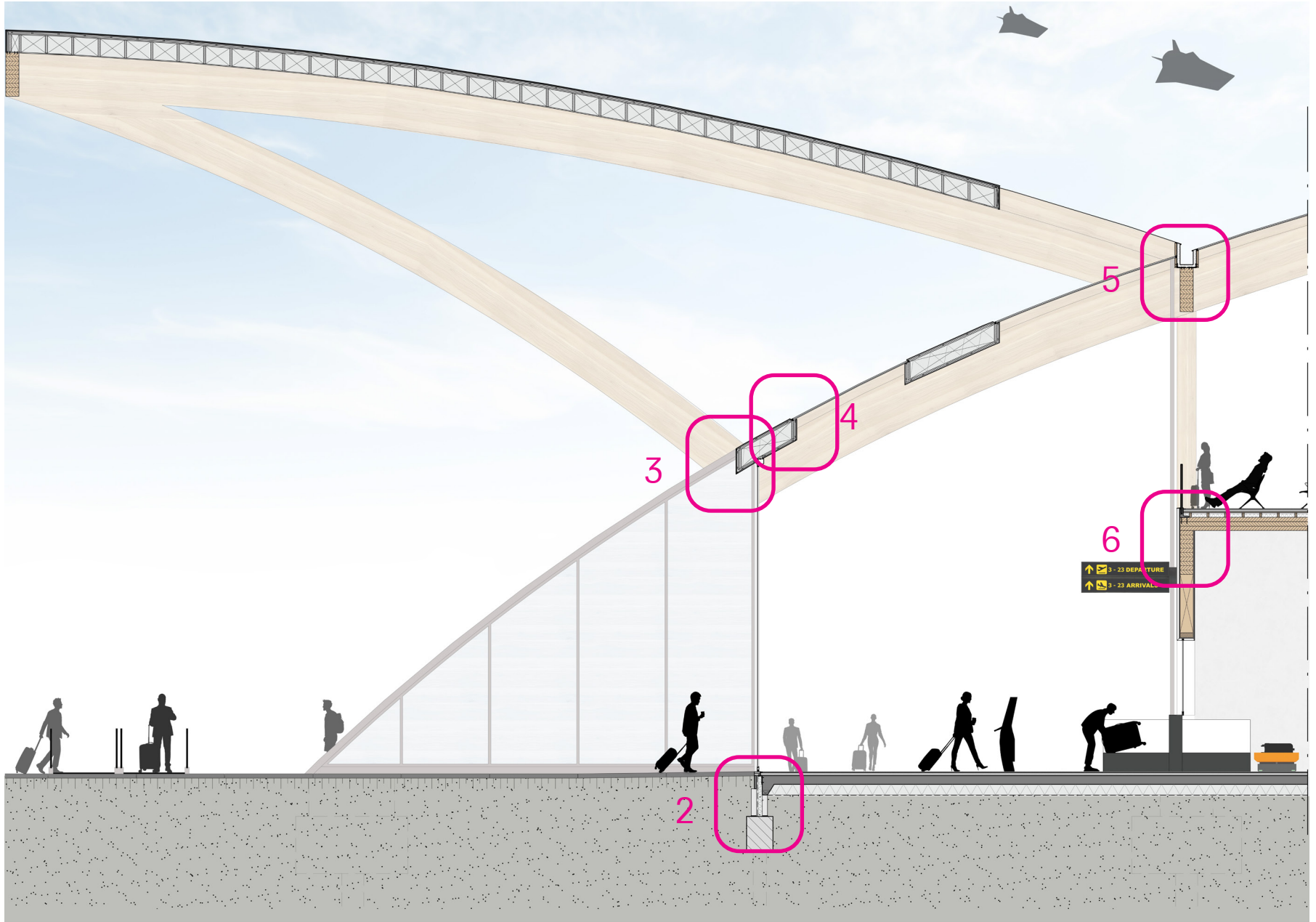



# DEVELOPMENT DETAILS

3

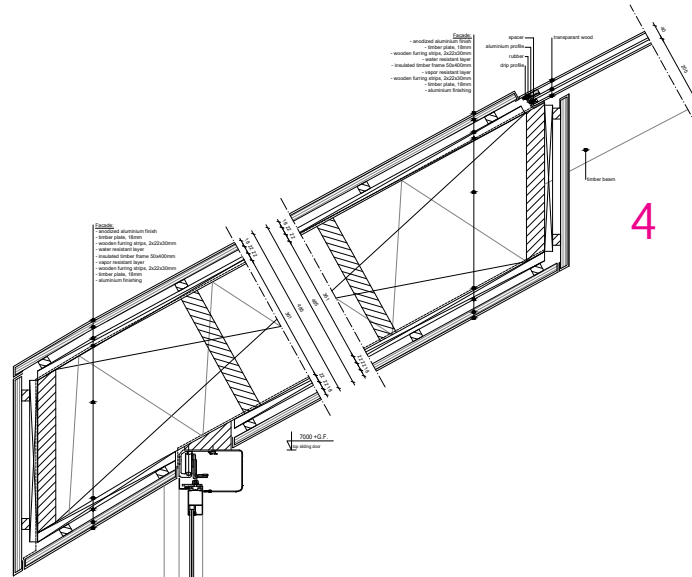

4

2

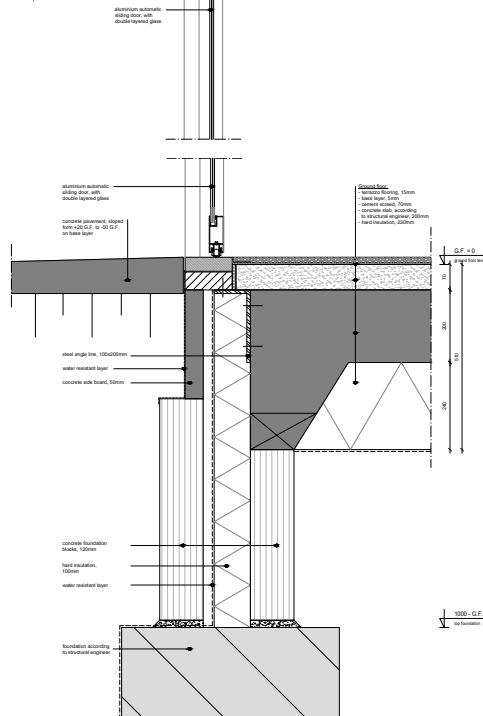

6

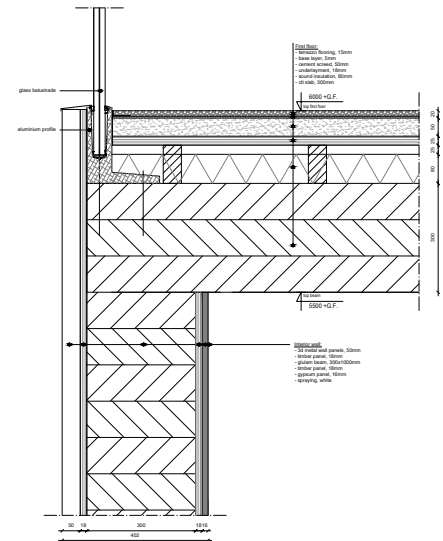

# DEVELOPMENT FRAGMENT

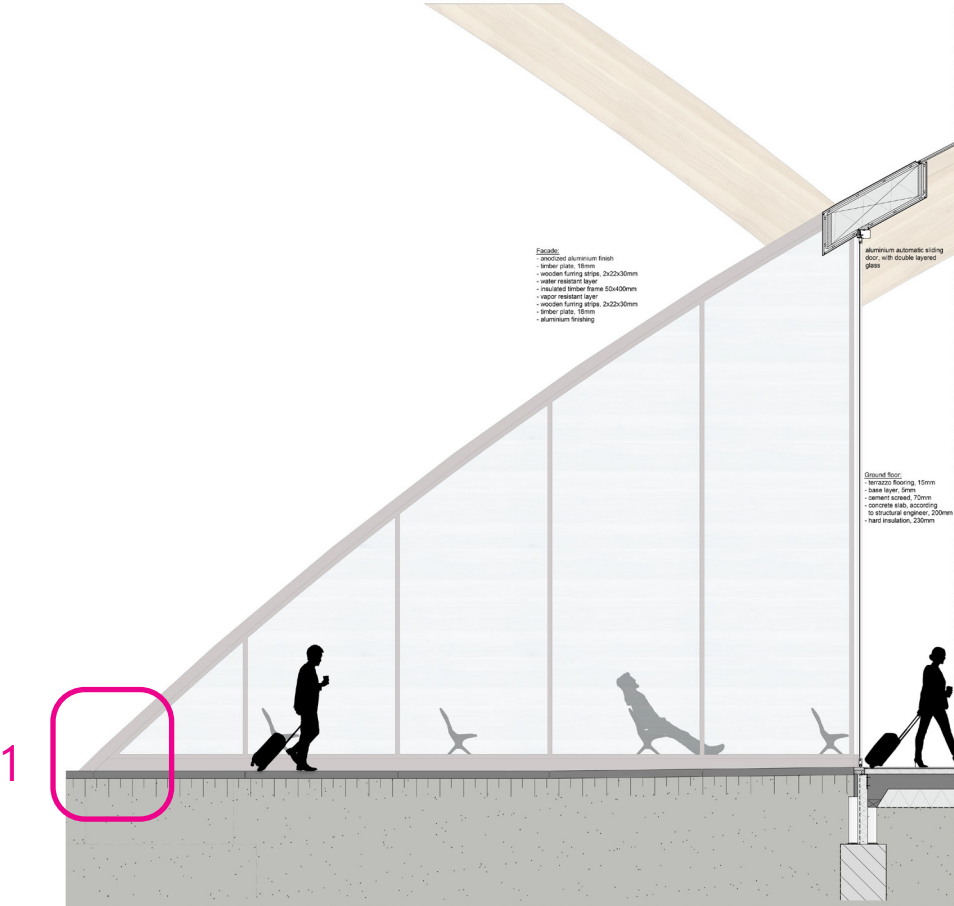
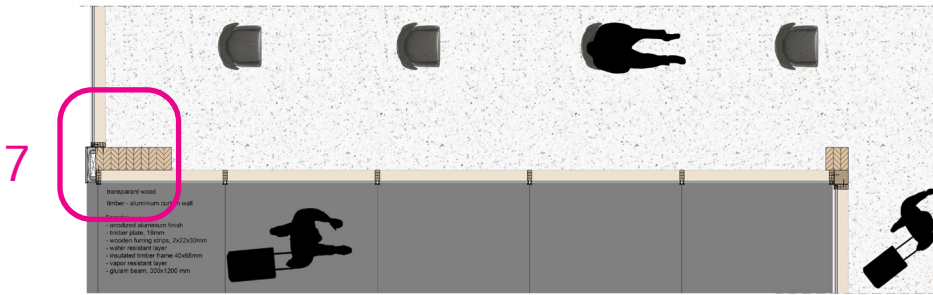

# DEVELOPMENT DETAILS

7

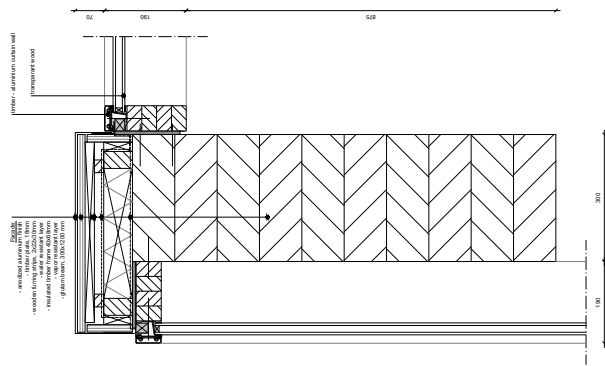

5

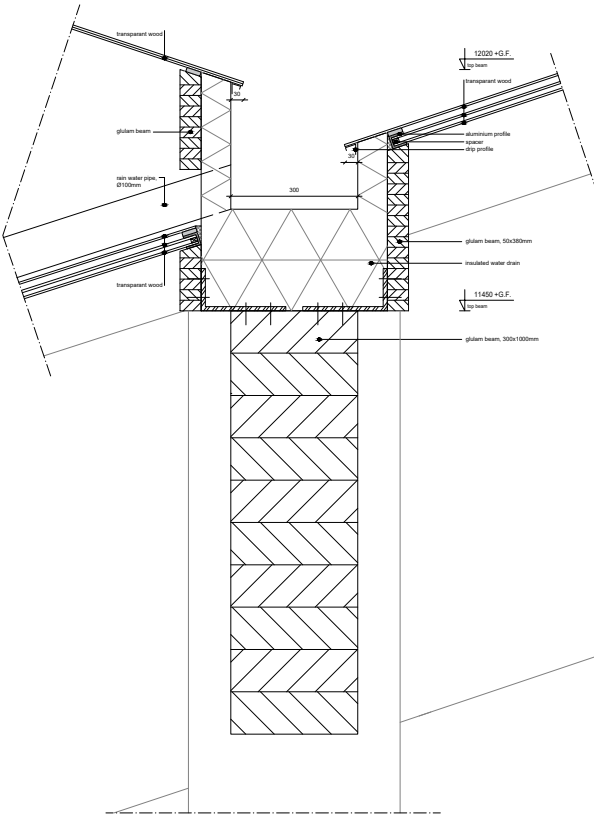

1

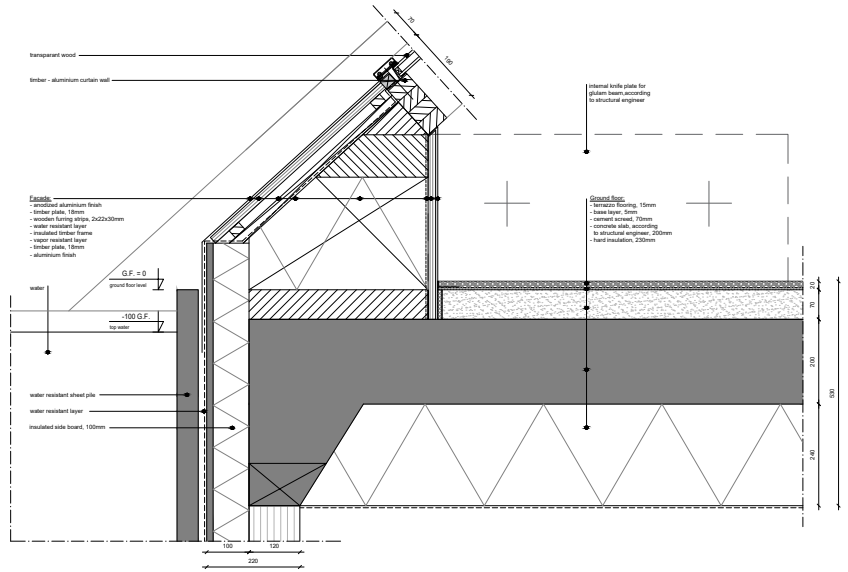

Supersonic Worldport - detail 1

01 INTRODUCTION

02 RESEARCH

& DESIGN BRIEF

03 CONCEPT

04 IMPLEMENTATION

05 DEVELOPMENT

**06 CONCLUSION**

CONCLUSION  
**RESEARCH QUESTION**

**HOW TO DESIGN  
AN AIRPORT TO  
ACCOMMODATE  
RECONFIGURATED  
EUROPEAN AVIATION  
INDUSTRY?**

CONCLUSION  
**ANSWER**



**BASE THE DESIGN ON  
THE PRINCIPLES**

CONCLUSION  
**ANSWER**



**Scientific Impact**





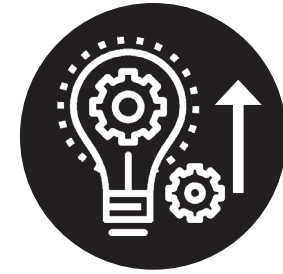



**Sustainable Development**



**Innovation Growth**

# CONCLUSION

## IMPLEMENTATION OF PRINCIPLES

- a 
- b 
- c 
- d 
- e 
- f 

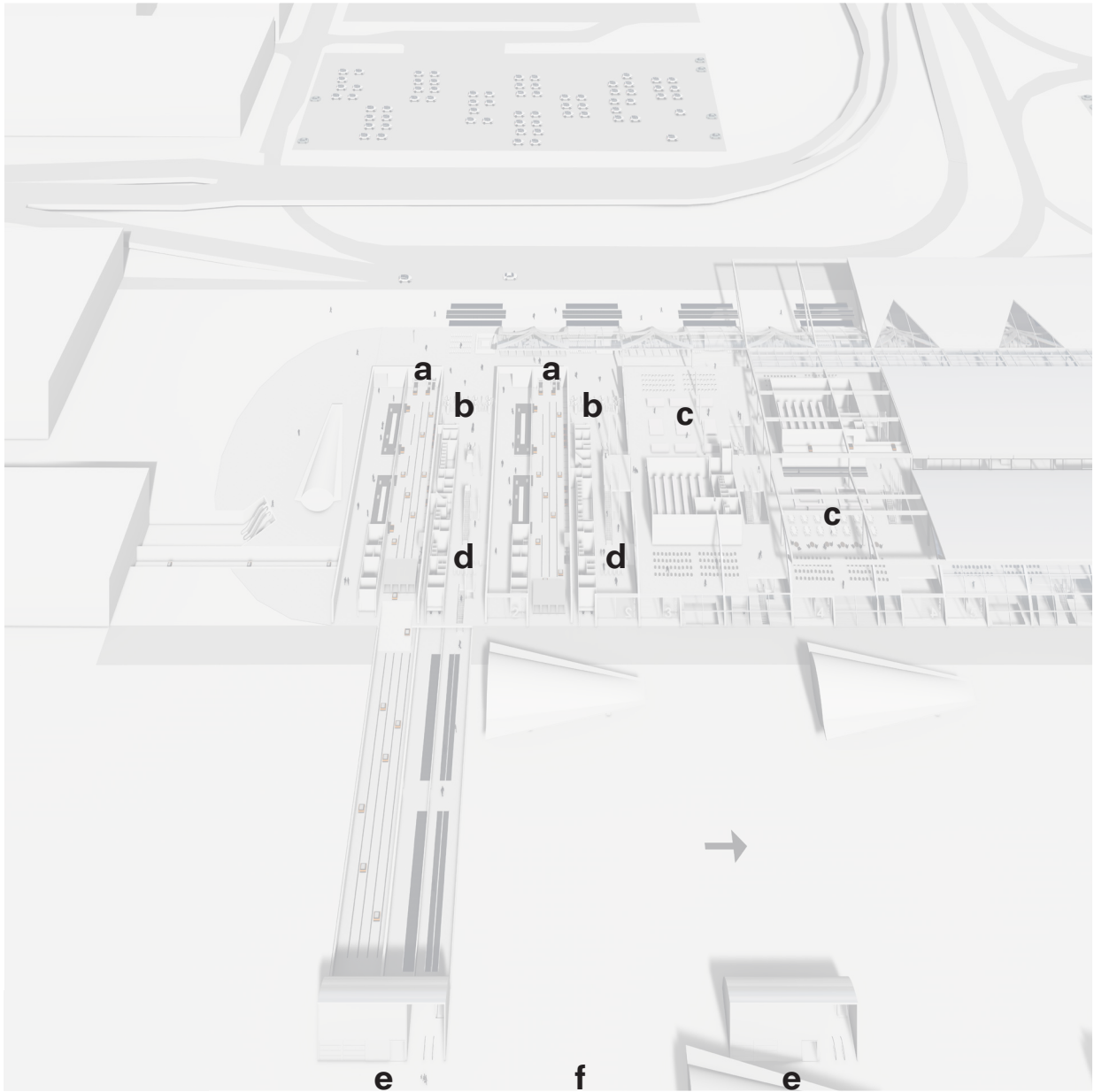



# THANK YOU