

Rammed Earth

Exploring the material's potential to address residential challenges within Central European suburbs.



P5
aE Studio

June 19, 2024

Larissa Götze

Let's build a landfill!

or: How can we turn non-hazardous soil excavations into buildings?

Let's build a landfill!

or: How can we turn non-hazardous soil excavations into buildings?

Why?

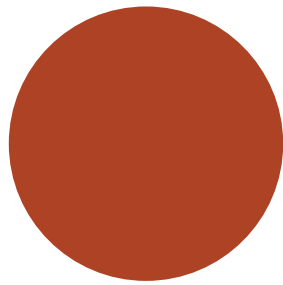

Environmental Challenges in Sub-urban Housing

Problem Statement

Context: Central Europe



Problem Statement



- Research
- Implementation
- Urban Scale
- Building Scale
- Recap

Sub Problem 1: New Buildings

Problem
Statement



Research

Implementation

Urban Scale

Building Scale

Recap



Erection of new residential building blocks in Dornbirn, Austria in 2023.

Sub Problem 2: Linear Use of Materials

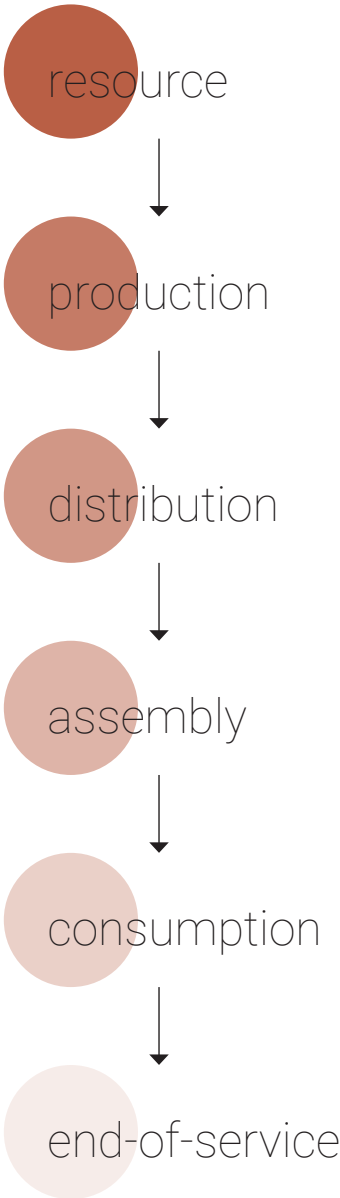

Problem Statement ●

Research

Implementation

Urban Scale

Building Scale

Recap

Structural material of residential buildings in Europe, 2017.

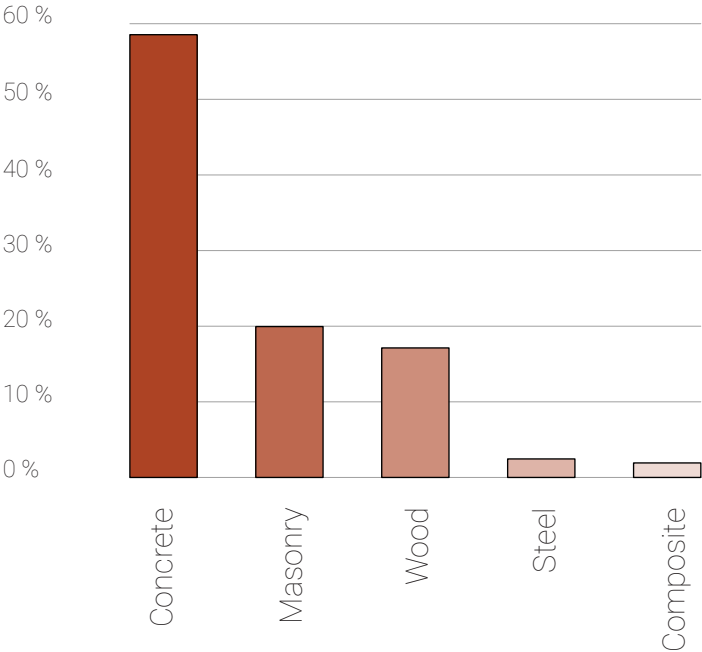

Sub Problem 3: Active Climate Control

Problem Statement ●

Research

Implementation

Urban Scale

Building Scale

Recap

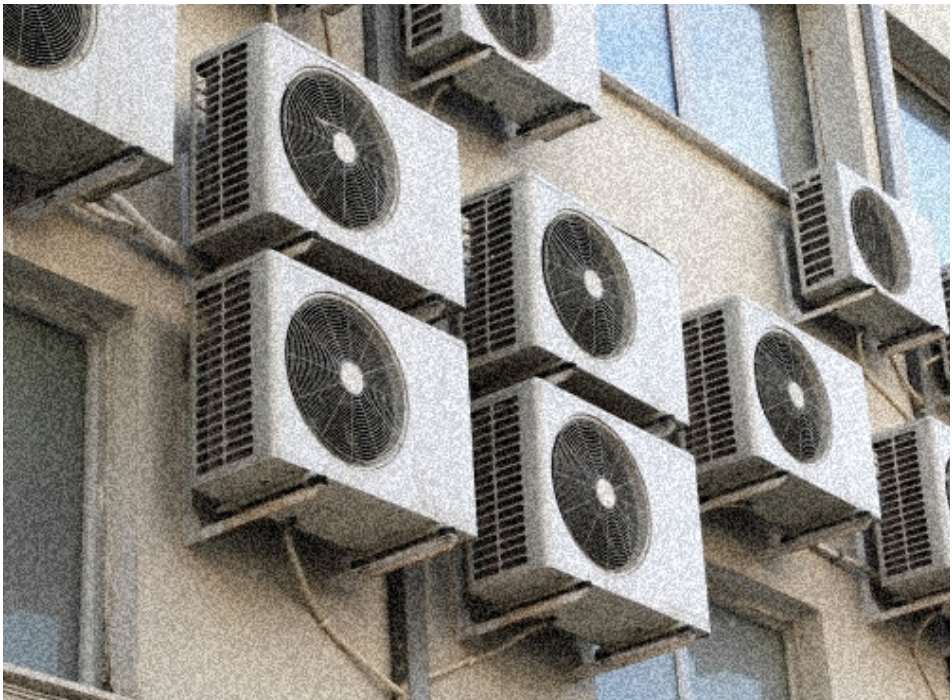

Increasing application of air conditioning units in Europe.

Total CO₂ emissions inherited in a new building, depending on its construction type and efficiency standard.

- operational energy
- grey emissions

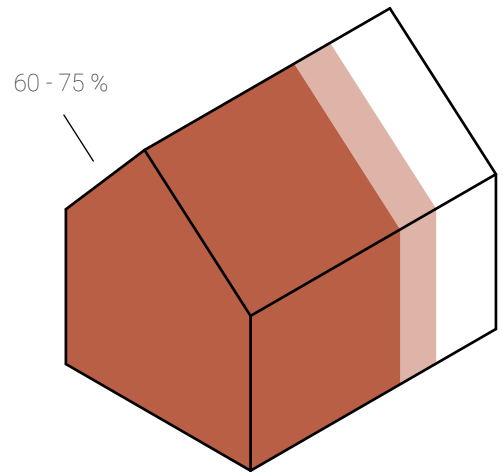

Sub Problem 4: Waste Contribution

Problem Statement



Research

Implementation

Urban Scale

Building Scale

Recap



Landfill site for soil excavations in Weiach, Switzerland.

The waste balance of Germany in 2020, compared in weight.

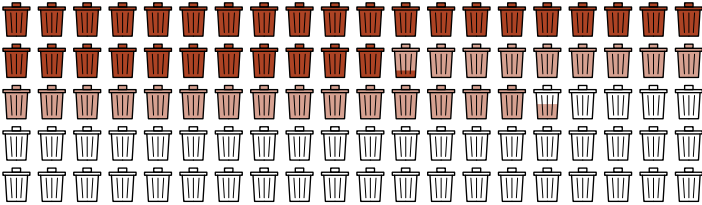

- non-hazardous soil excavation
- other building related waste
- non-building related waste

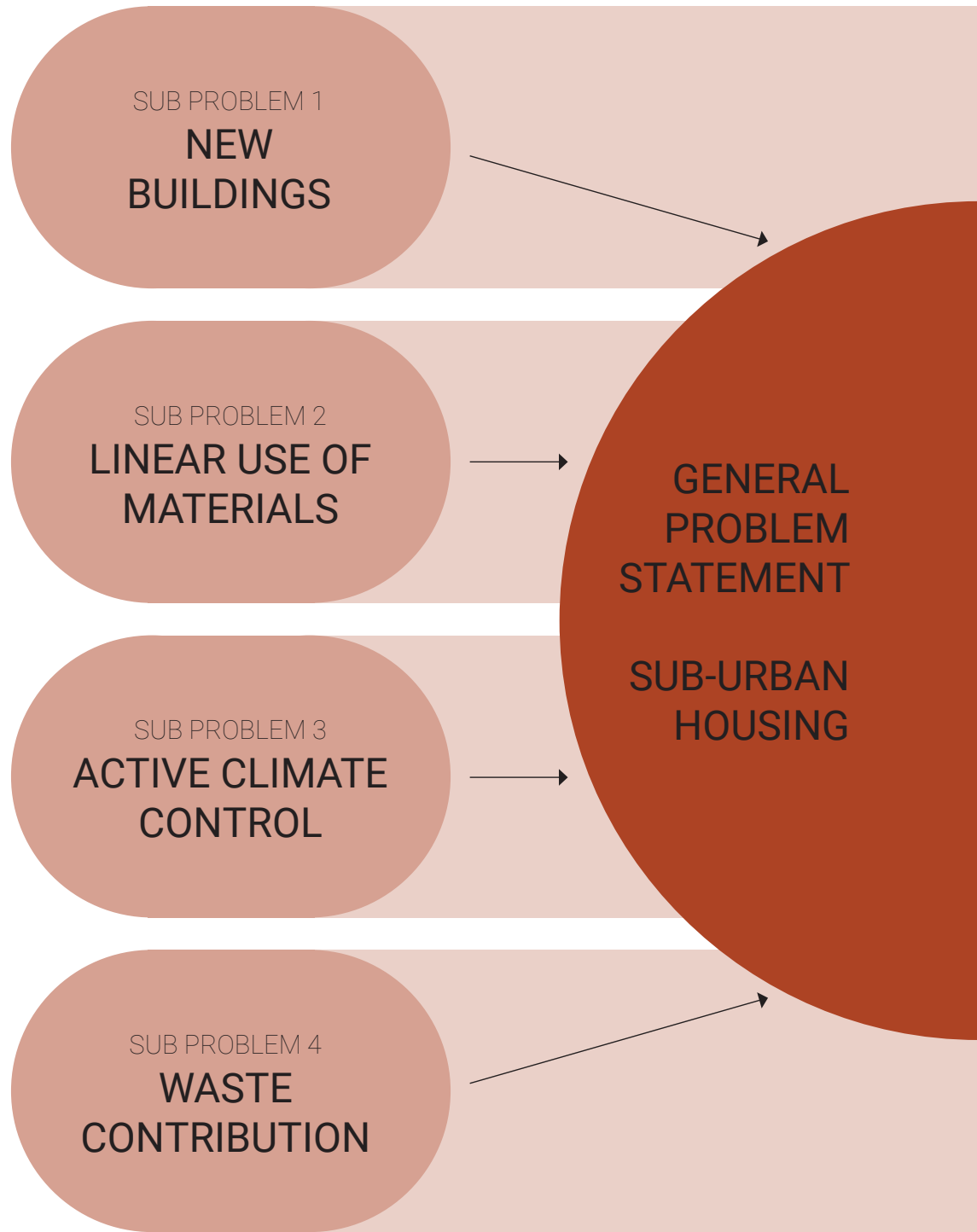

Problem Statement



- Research
- Implementation
- Urban Scale
- Building Scale
- Recap

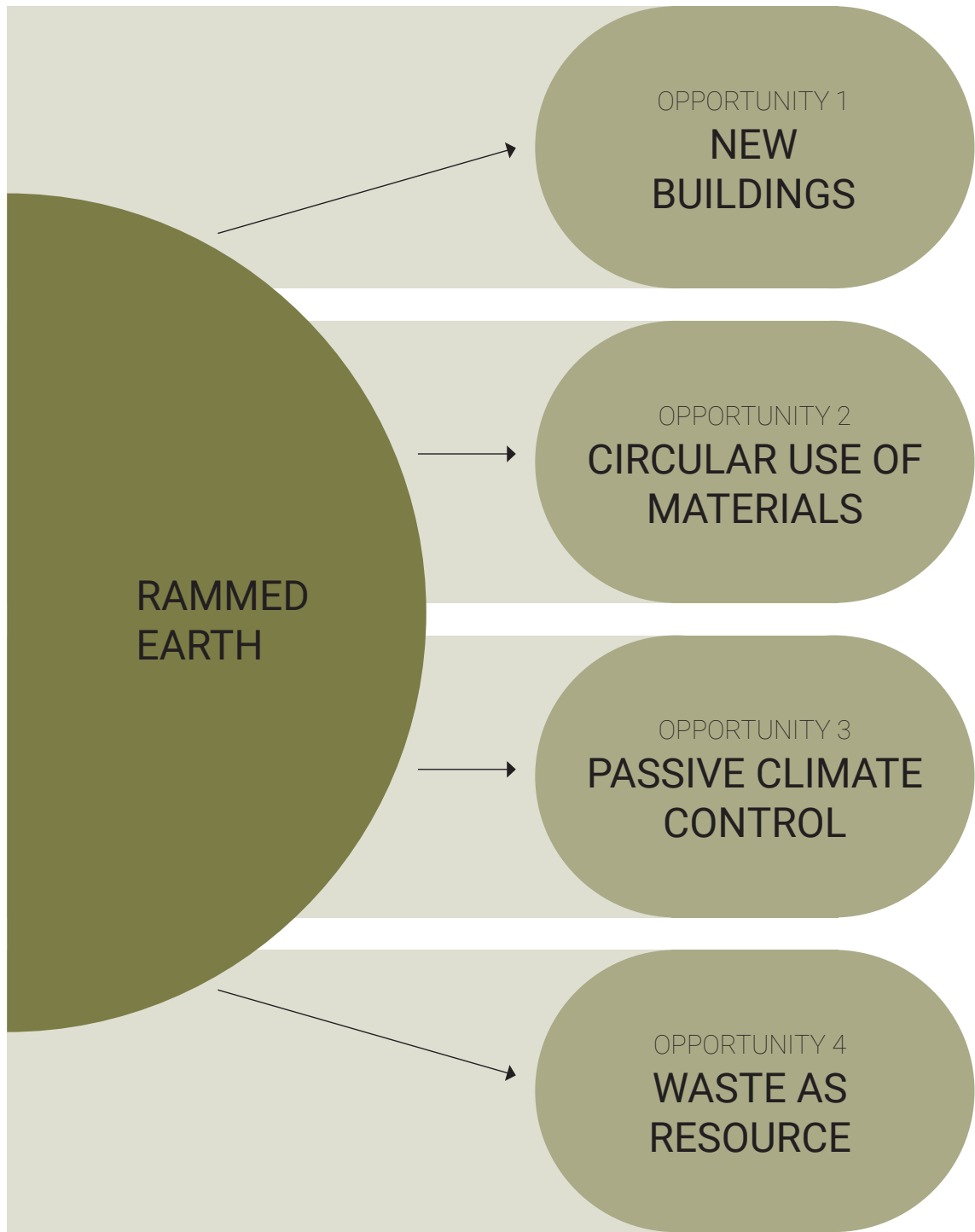

Problem Statement



- Research
- Implementation
- Urban Scale
- Building Scale
- Recap

Opportunity 1: New Buildings

Problem Statement



Research

Implementation

Urban Scale

Building Scale

Recap



Highest rammed earth building in Germany, built in Weilburg before 1836.

Number of new multi-family residential houses in Switzerland 2022, structured in number of stories.

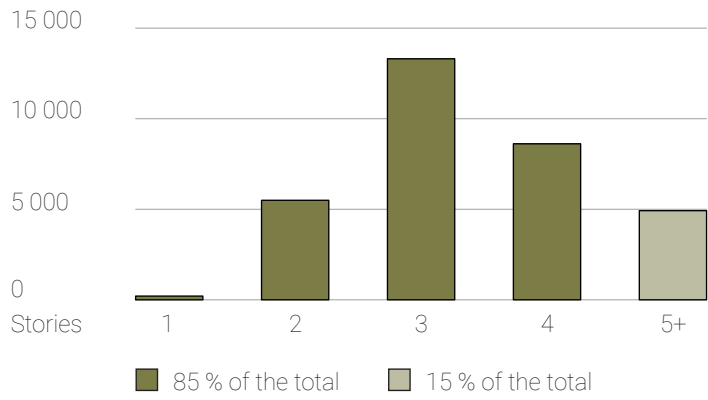

Opportunity 2: Circular Use of Materials

Problem Statement



Research

Implementation

Urban Scale

Building Scale

Recap

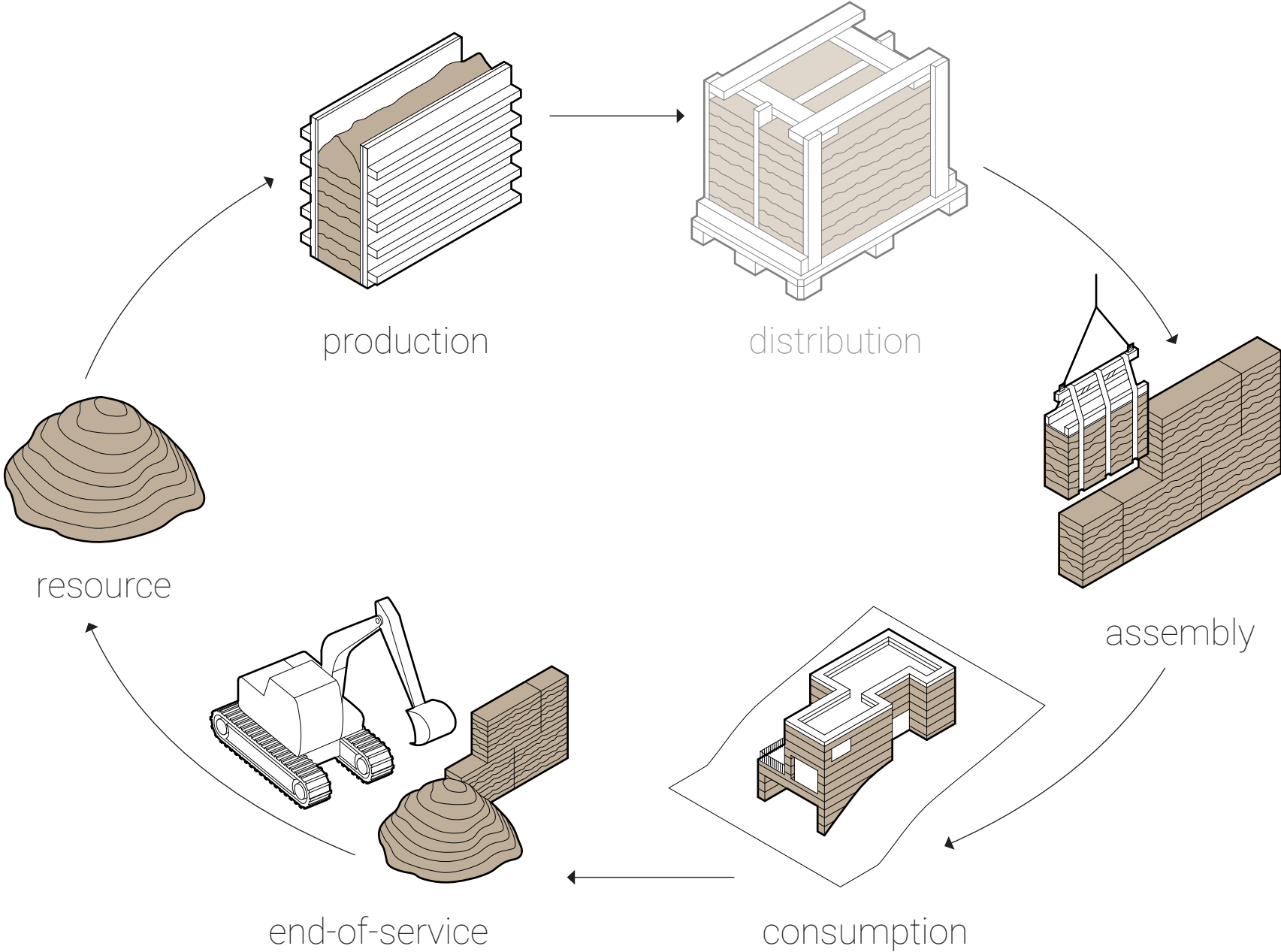

Opportunity 3: Passive Climate Control

Problem Statement



Research

Implementation

Urban Scale

Building Scale

Recap

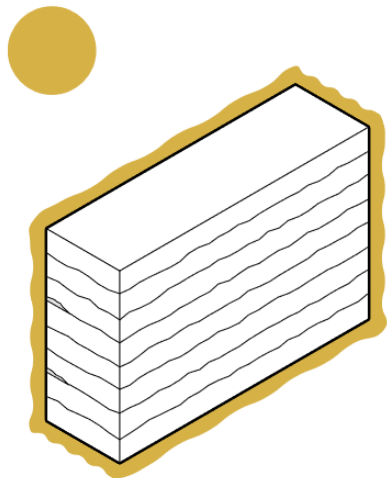

thermal mass

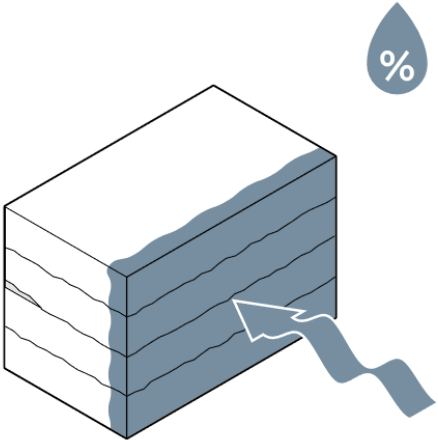
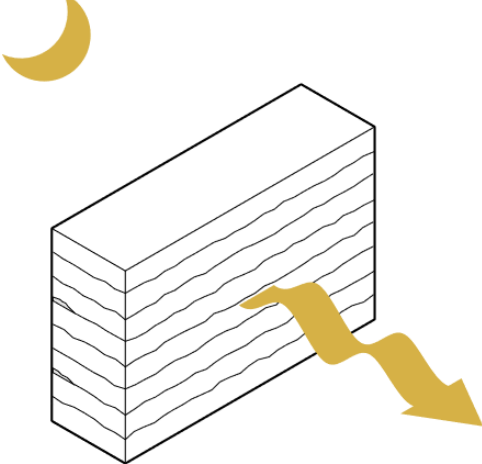

vapour openness

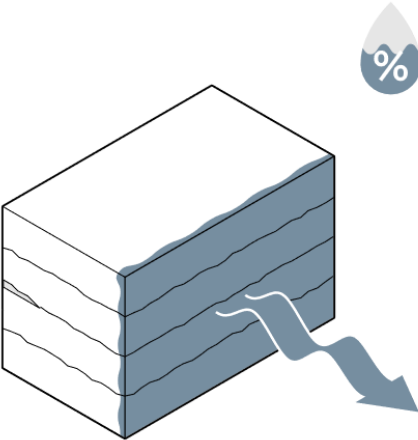

Opportunity 4: Waste as Resource

Problem Statement



Research

Implementation

Urban Scale

Building Scale

Recap



Haus Rauch in Schlins, Austria, made from 100% local soil excavation in 2008.



Rammed earth mixture.

Let's build a landfill!

or: How can we turn non-hazardous soil excavations into buildings?

How?

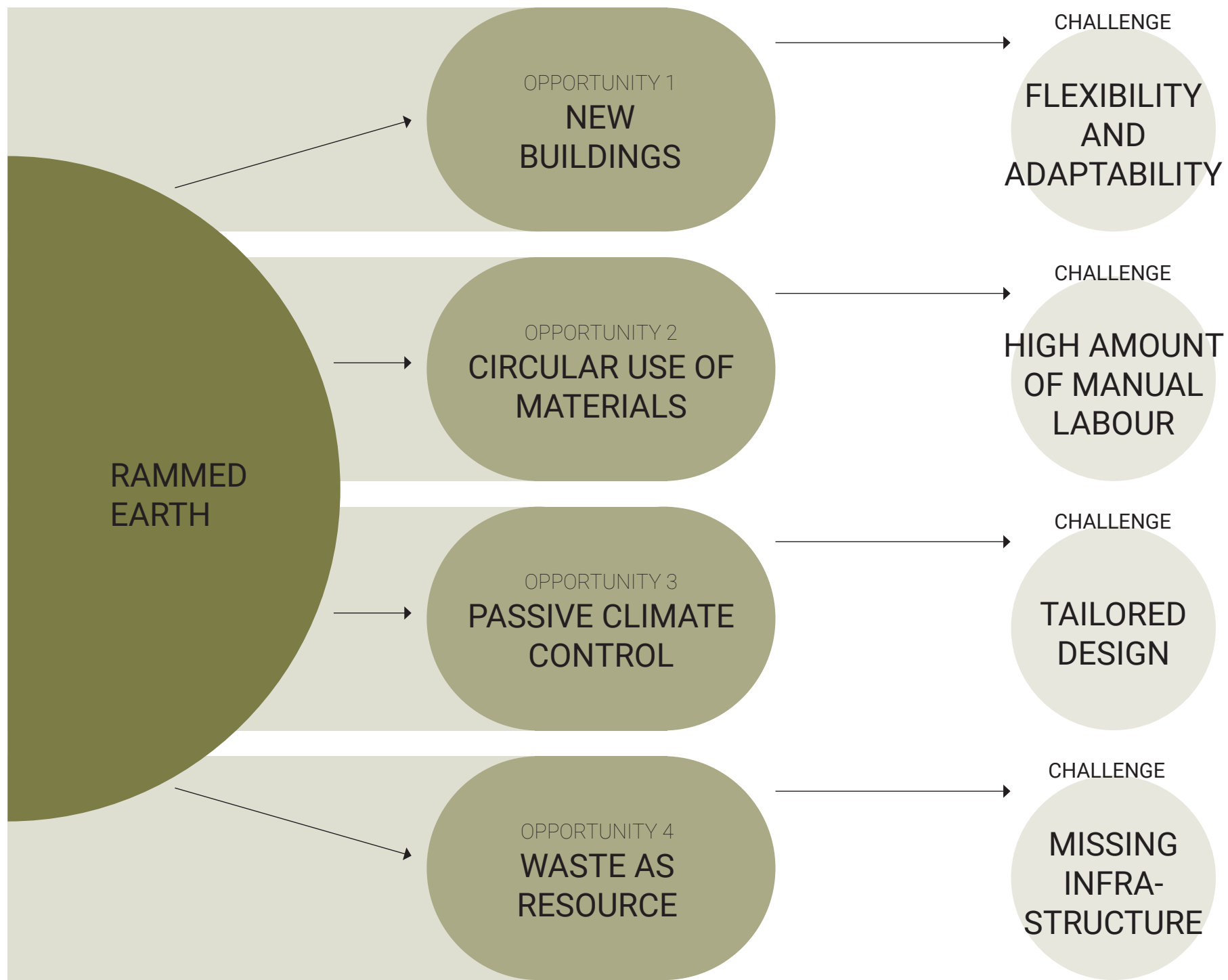

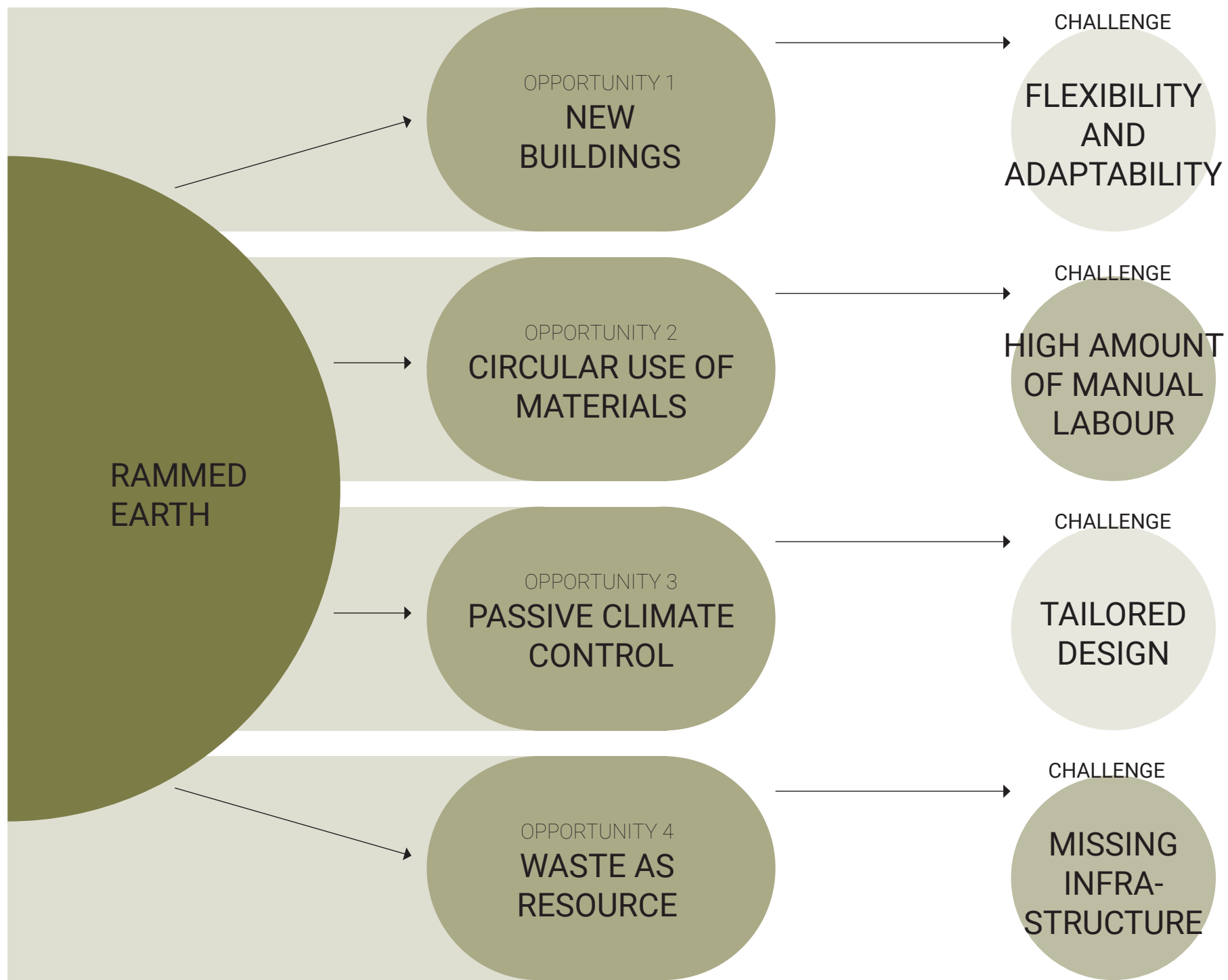

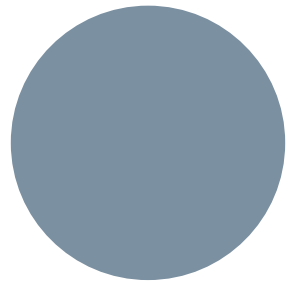

Research

Workshop Amsterdam (NL)



BC Materials Brussels (BE)



Online Course criti.co

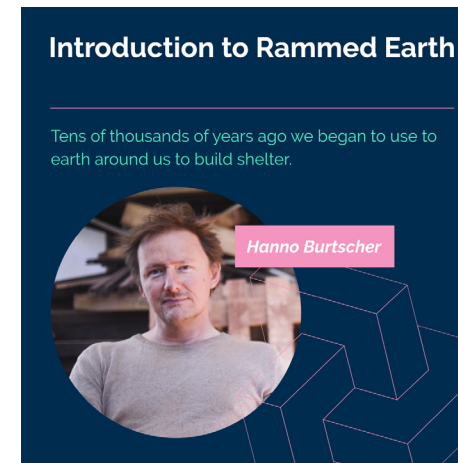

Problem
Statement

Research

Implementation

Urban Scale

Building Scale

Recap

Lehm Ton Erde Schlins (AT)



August Lücking Warburg (DE)



Patrick Kreckl Atelier AHA, IG Lehm



Research Question

How can advancements in rammed earth prefabrication allow for broader use of the material in multi-family residential buildings in the sub-urban Central European context?

Problem
Statement

Research



Implementation

Urban Scale

Building Scale

Recap

Case Studies

August Lücking GmbH & Co. KG Warburg (DE)

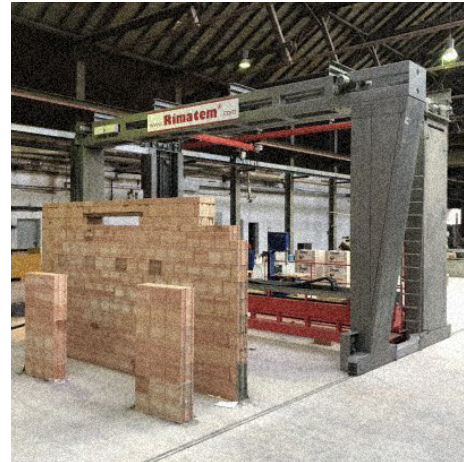

Lehm Ton Erde Baukunst GmbH Schlins (AT)

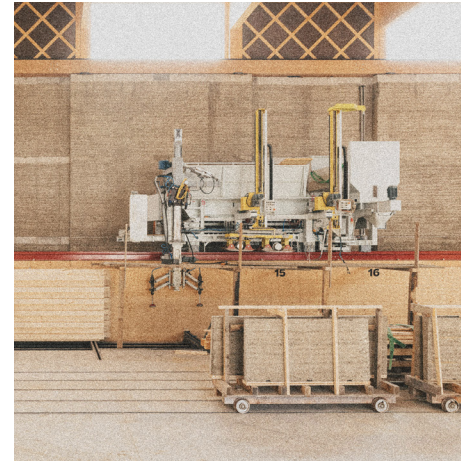

ERNE AG Holzbau Laufenburg (CH)



Le Pisé Chambles (FR)

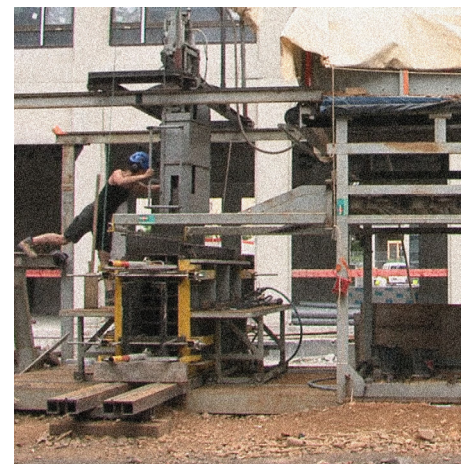

Problem
Statement

Research



Implementation

Urban Scale

Building Scale

Recap

Pugh Matrix

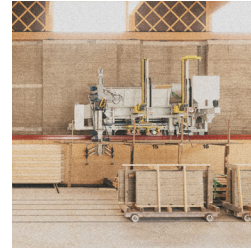
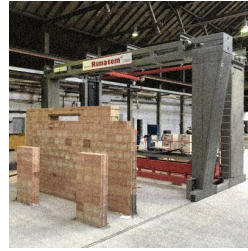

Problem Statement

Research



Implementation

Urban Scale

Building Scale

Recap

August Lücking GmbH & Co. KG
Warburg (DE)

Lehm Ton Erde Baukunst GmbH
Schlins (AT)

ERNE AG Holzbau
Laufenburg (CH)

Le Pisé
Chambles (FR)

EFFICIENCY

TRANSPORT OF RAW MATERIAL

- +1 There is very little to no transport.
- 0 Transport routes are kept to a minimum.
- 1 Transport routes are not kept to a minimum.

-1

0

+1

+1

COMPOSITION

- +2 There are almost standardized properties in each batch of raw materials.
- 0 There is a little variation in properties in each batch of raw materials.
- 2 There is a great variation in properties in each batch of raw materials.

+2

0

-2

-2

FORMWORK ASSEMBLY AND DISASSEMBLY

- +1 A mostly automated process is used.
- 0 A mix of manual labour and automated processes is used.
- 1 Most work is being done manually.

-1

0

0

-1

MATERIAL FEEDING

- +1 A mostly automated process is used.
- 0 A mix of manual labour and automated processes is used.
- 1 Most work is being done manually.

-1

+1

0

0

RAMMING PROCESS

- +2 A mostly automated process is used.
- 0 A mix of manual labour and automated processes is used.
- 2 Most work is being done manually.

0

+2

+2

-2

August Lücking
GmbH & Co. KG
Warburg (DE)

Lehm Ton Erde
Baukunst GmbH
Schlins (AT)

ERNE AG Holzbau
Laufenburg (CH)

Le Pisé
Chambles (FR)

Problem
Statement

Research



Implementation

Urban Scale

Building Scale

Recap

TRANSPORT OF ELEMENTS

- +1 There is very little to no transport.
- 0 Transport routes are kept to a minimum.
- 1 Transport routes are not kept to a minimum.

0

-1

0

+1

TOUCH-UP WORK

- +2 Very little to no touch-up work is required.
- 0 Touch-up work is required only in horizontal or vertical direction.
- 2 Touch-up work is required in horizontal and vertical direction.

+2

0

0

-2

SUBTOTAL

+1

+2

+1

-5

AESTHETICS

FREEDOM IN DESIGN

- +2 There is high customizability in formwork possible (high flexibility in size and shape).
- 0 There is medium customizability in formwork possible (flexibility in size or shape).
- 2 There is low customizability in formwork possible (little flexibility in size and shape).

0

-2

+2

0

UNITY IN LAYERS

- +1 Optically continuous rammed earth layers in very long walls are possible.
- 0 Optically continuous rammed earth layers in medium long walls are possible.
- 1 Optically continuous rammed earth layers in only short walls are possible.

0

+1

0

-1

SUBTOTAL

0

-1

+2

-1

August Lücking
GmbH & Co. KG
Warburg (DE)

Lehm Ton Erde
Baukunst GmbH
Schlins (AT)

ERNE AG Holzbau
Laufenburg (CH)

Le Pisé
Chambles (FR)

Problem
Statement

Research



Implementation

Urban Scale

Building Scale

Recap

CIRCULARITY

RAW MATERIAL

- +2 Mainly secondary resources from landfill / construction sites are used.
- 0 A mix of primary and secondary resources is used.
- 2 Mainly primary resources, excavated just for rammed earth, are used.

-2

+2

+2

+2

INFRASTRUCTURE FOR PRODUCTION

- +2 Mostly already existing and in use facilities, machinery, and tools are used.
- 0 Conventionally available facilities, machinery, and tools are used.
- 2 Highly specialized facilities, machinery, and tools are used.

+2

-2

0

-2

END-OF-LIFE

- +1 The material can be fully recycled without a loss of quality.
- 0 The material can be partially recycled.
- 1 The material can not be recycled.

+1

+1

+1

+1

SUBTOTAL

+1

+1

+3

+1

TOTAL

+2

+2

+6

-5

Sub Questions

Problem
Statement

Research



Implementation

Urban Scale

Building Scale

Recap

How can advancements in rammed earth prefabrication allow for broader use of the material in multi-family residential buildings in the sub-urban Central European context?

Q1. What are the current values and bottlenecks in the prefabrication of rammed earth elements that influence their efficiency, circularity, and aesthetics?

Requirements for Residential Housing Blocks

Problem Statement

Research



Implementation

Urban Scale

Building Scale

Recap

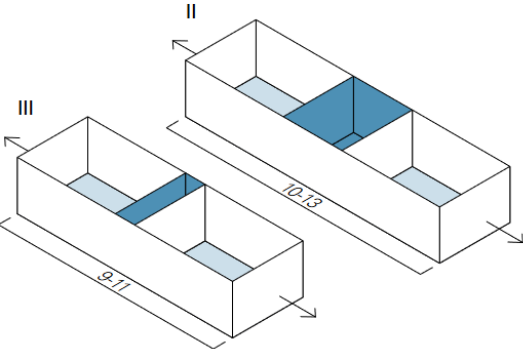

Building depths according to the "Raumpilot".

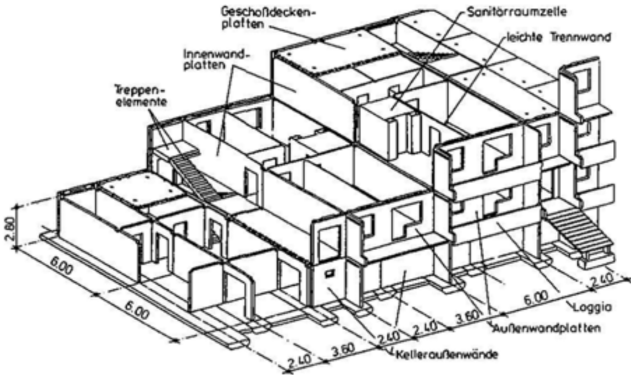

Sketch of the "WBS 70".



A model of an exemplary floor plan of a building from the "Wohnbauserie 70".

Sub Questions

Problem
Statement

Research



Implementation

Urban Scale

Building Scale

Recap

How can advancements in rammed earth prefabrication allow for broader use of the material in multi-family residential buildings in the sub-urban Central European context?

Q1. What are the current values and bottlenecks in the prefabrication of rammed earth elements that influence their efficiency, circularity, and aesthetics?

Q2. How can prefabricated rammed earth elements be used in a modular way that responds to requirements for housing purposes?

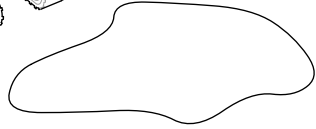
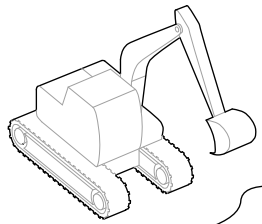

non-hazardous soil from
road, tunnel, building and
other construction works

Problem
Statement

Research



Implementation

Urban Scale

Building Scale

Recap

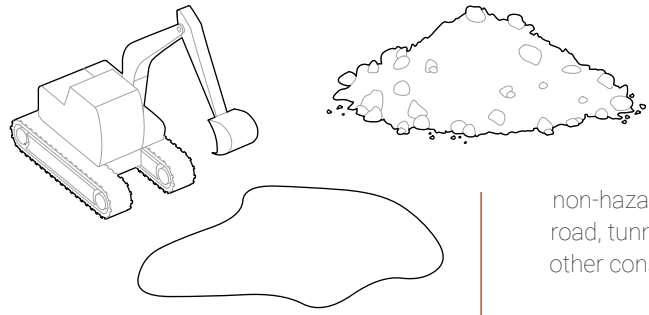

non-hazardous soil from
road, tunnel, building and
other construction works

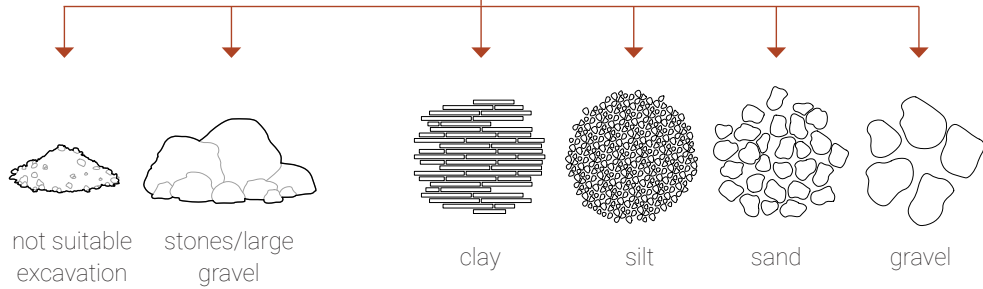

Problem
Statement

Research



Implementation

Urban Scale

Building Scale

Recap

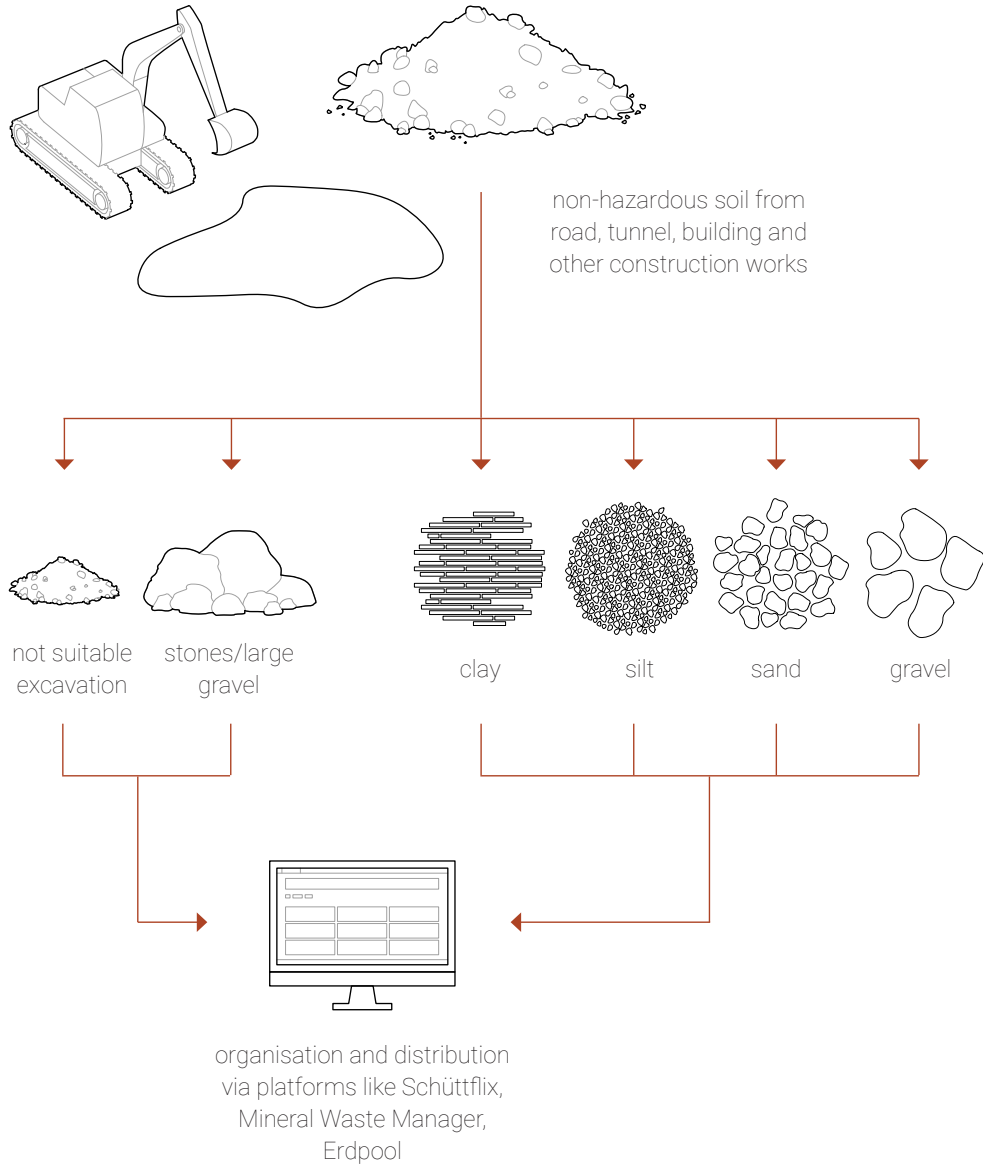

Problem Statement

Research



Implementation

Urban Scale

Building Scale

Recap

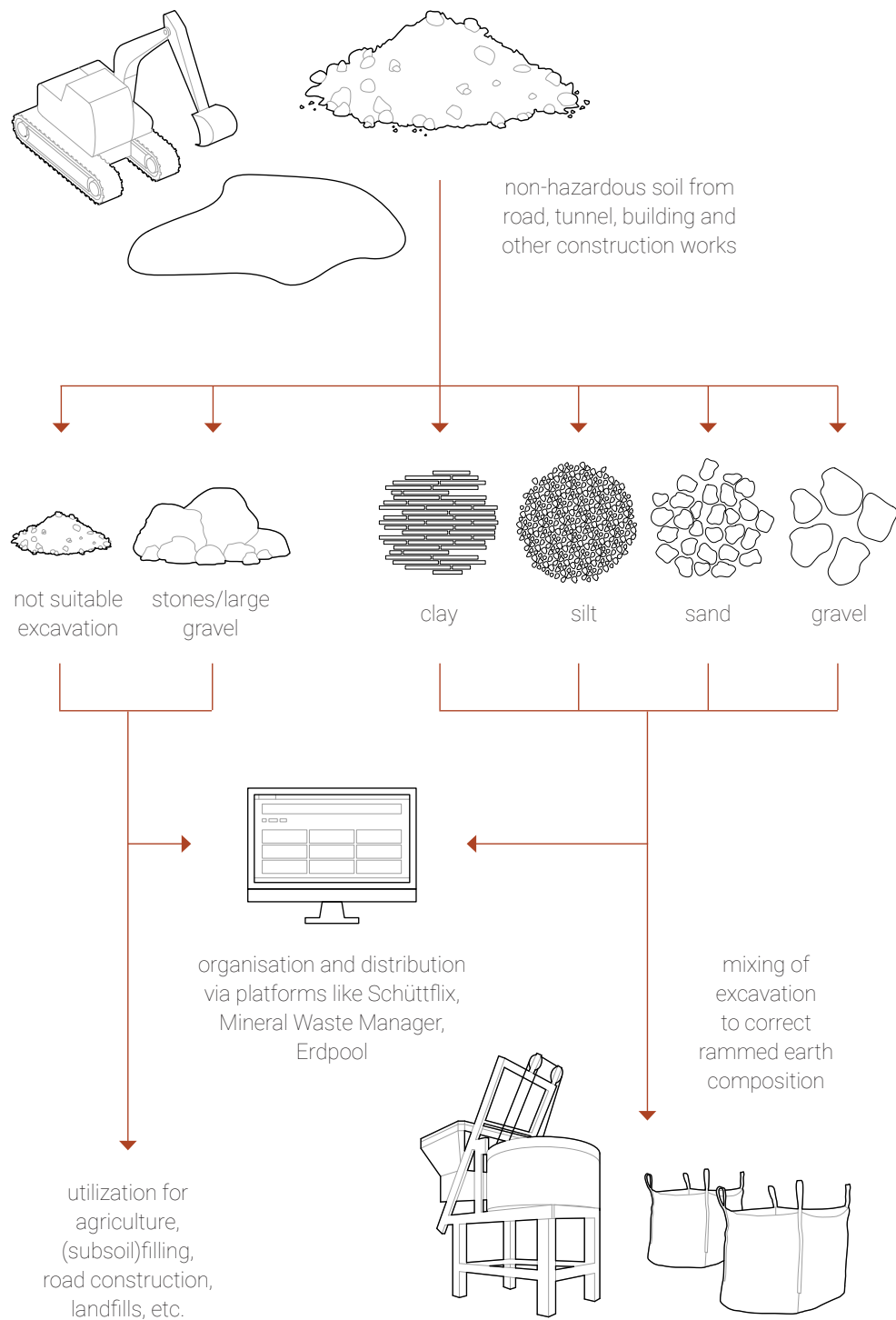

Problem Statement

Research



Implementation

Urban Scale

Building Scale

Recap

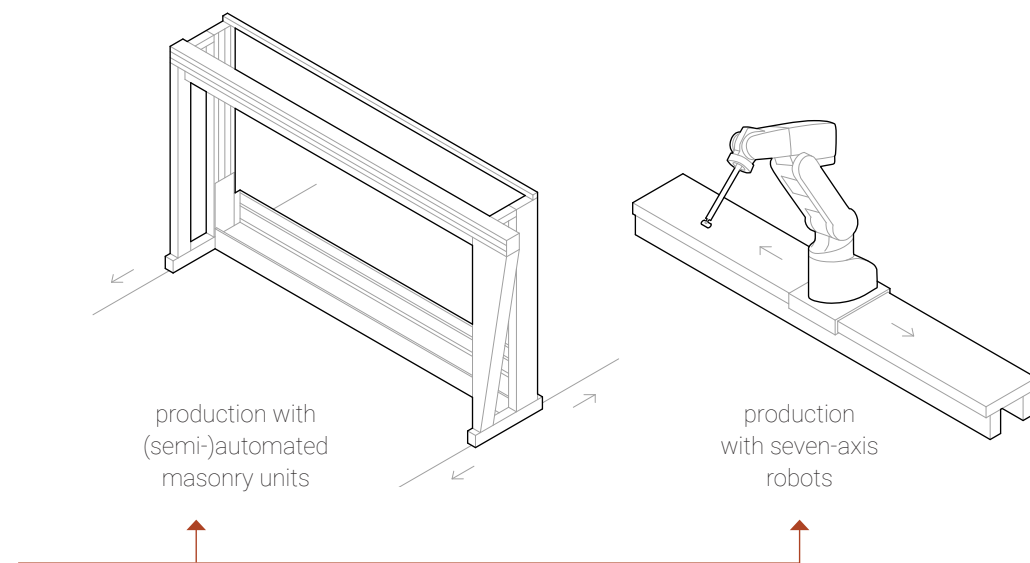
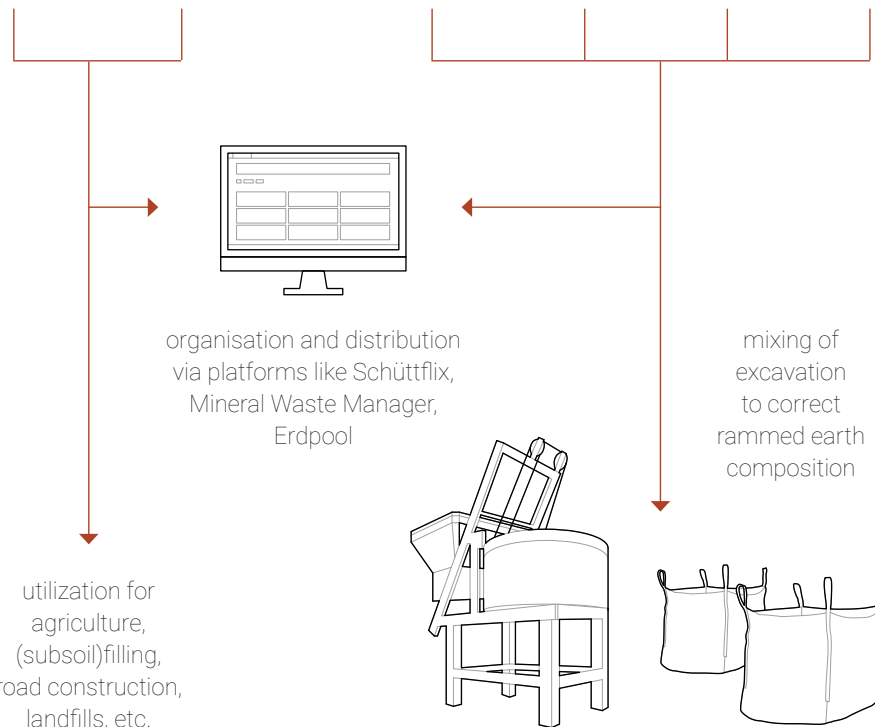
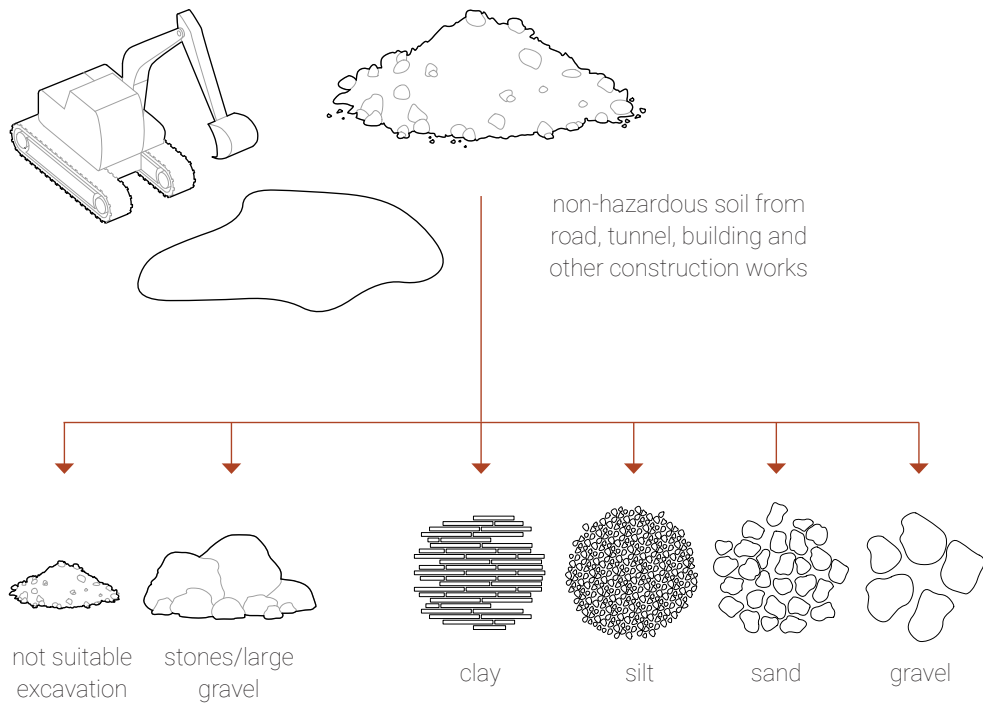

Problem Statement

Research



Implementation

Urban Scale

Building Scale

Recap

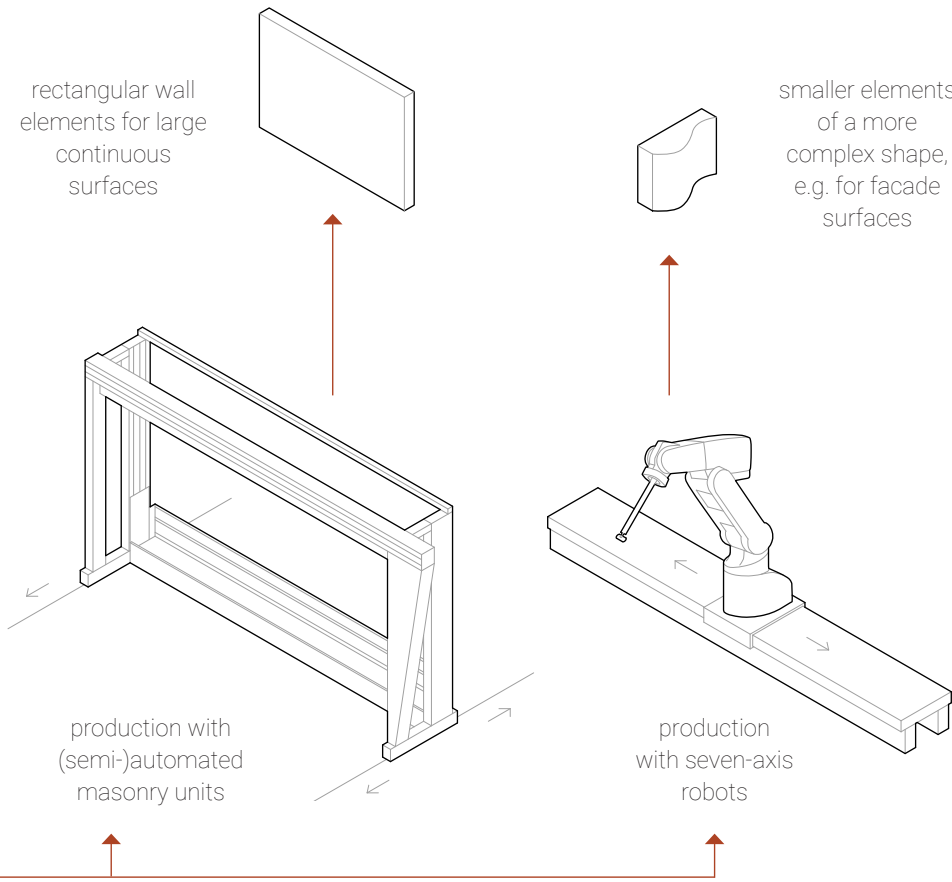
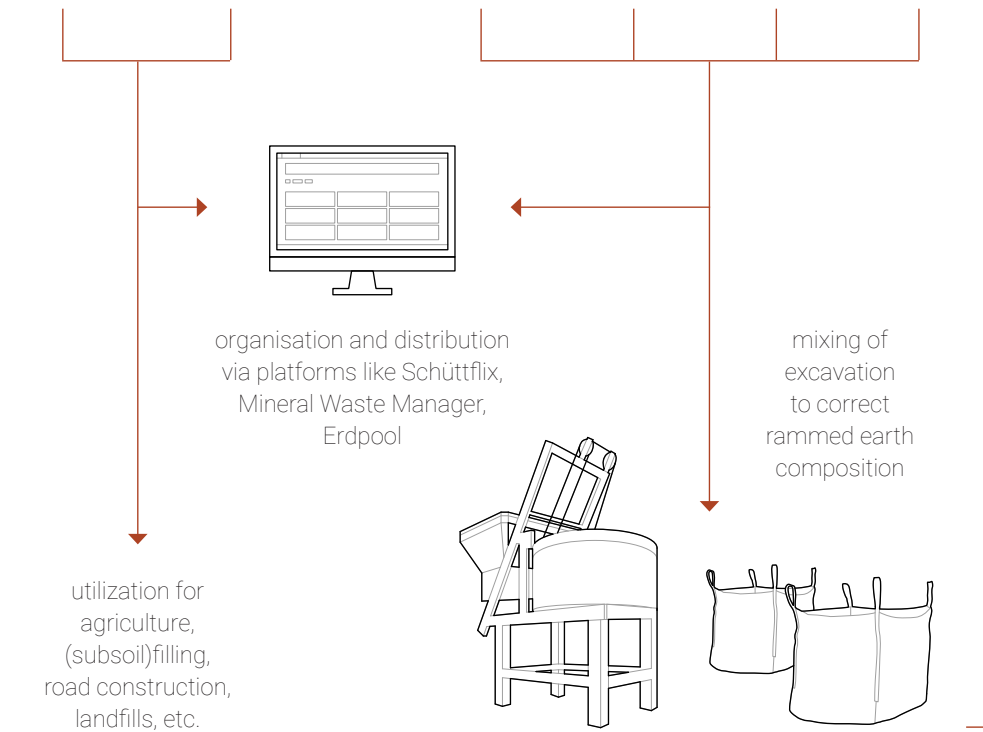
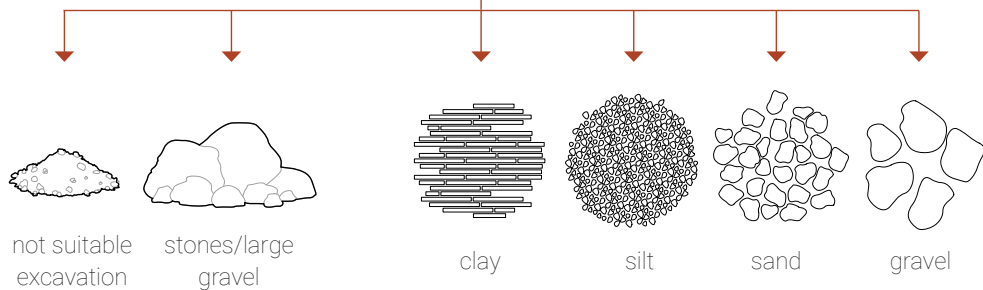
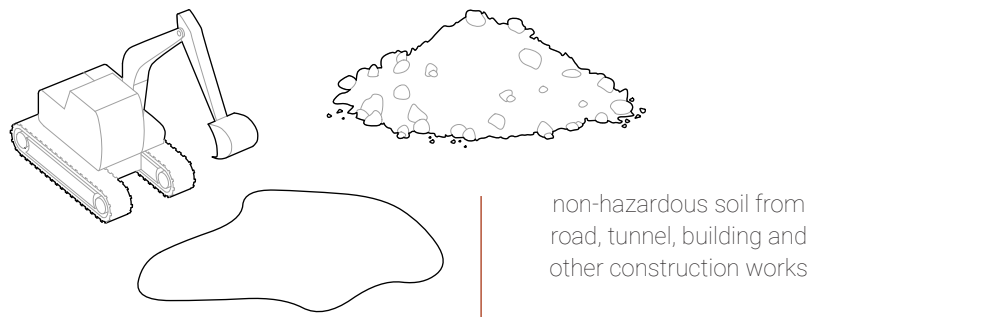

Problem Statement

Research



Implementation

Urban Scale

Building Scale

Recap

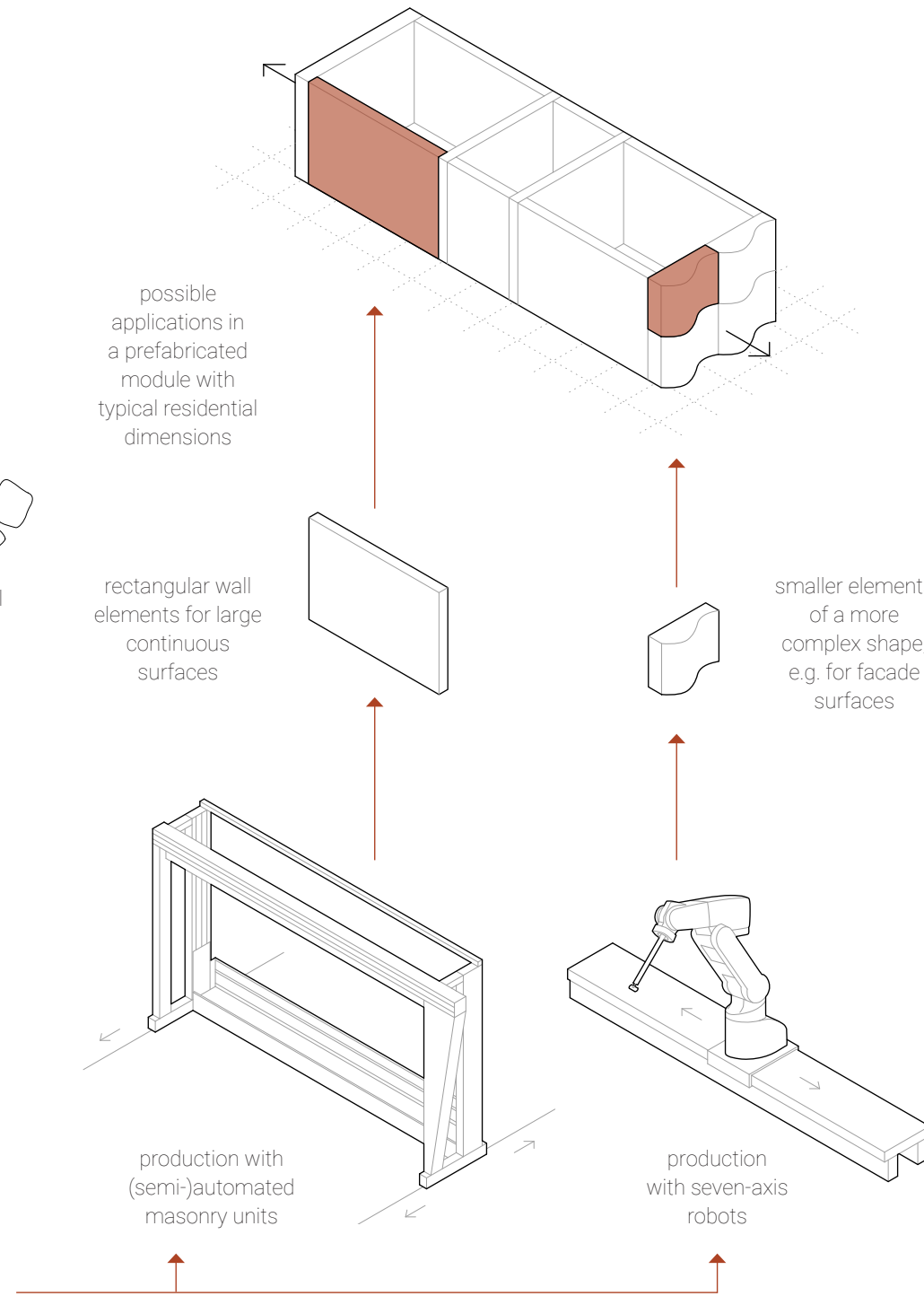
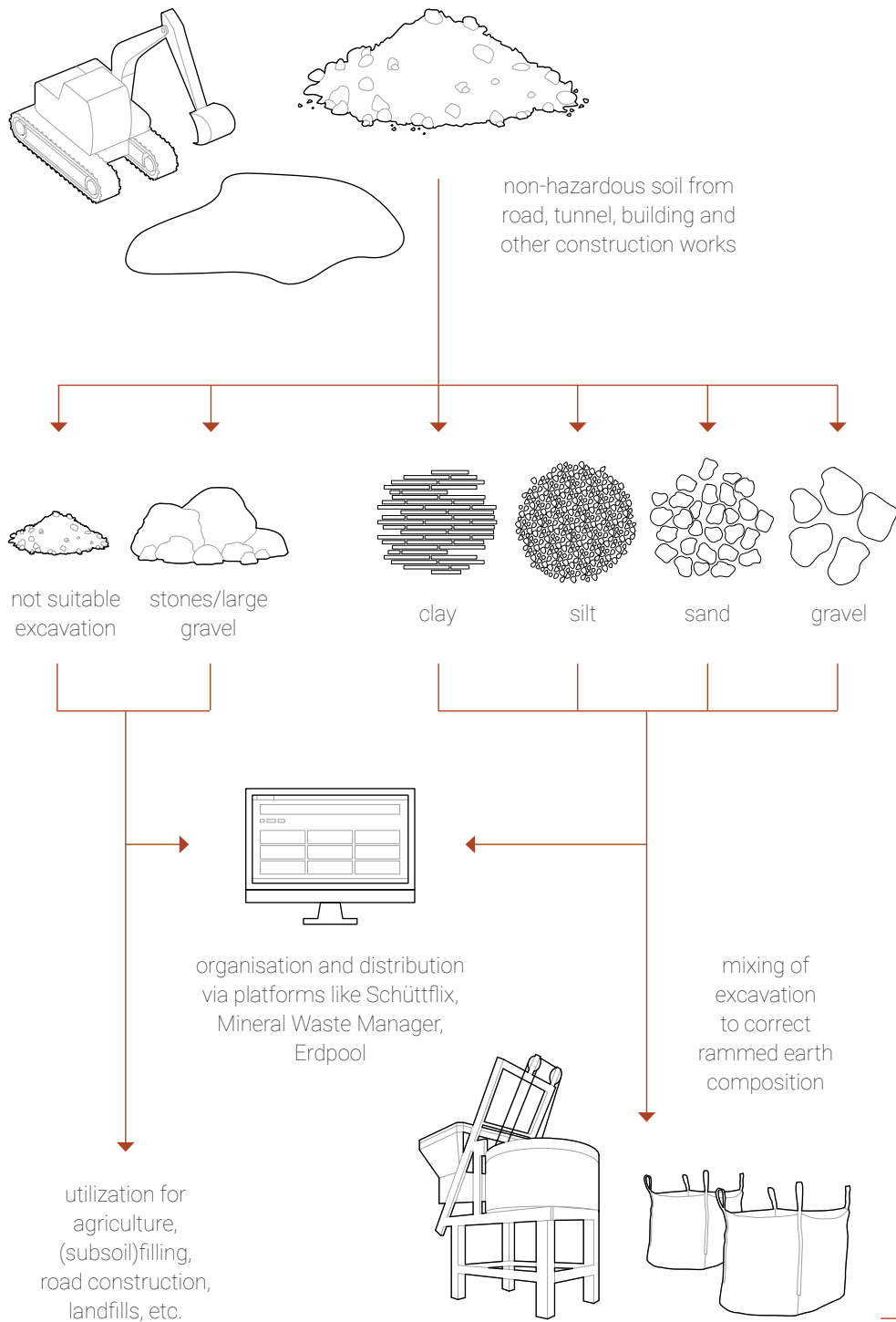

Problem Statement

Research



Implementation

Urban Scale

Building Scale

Recap

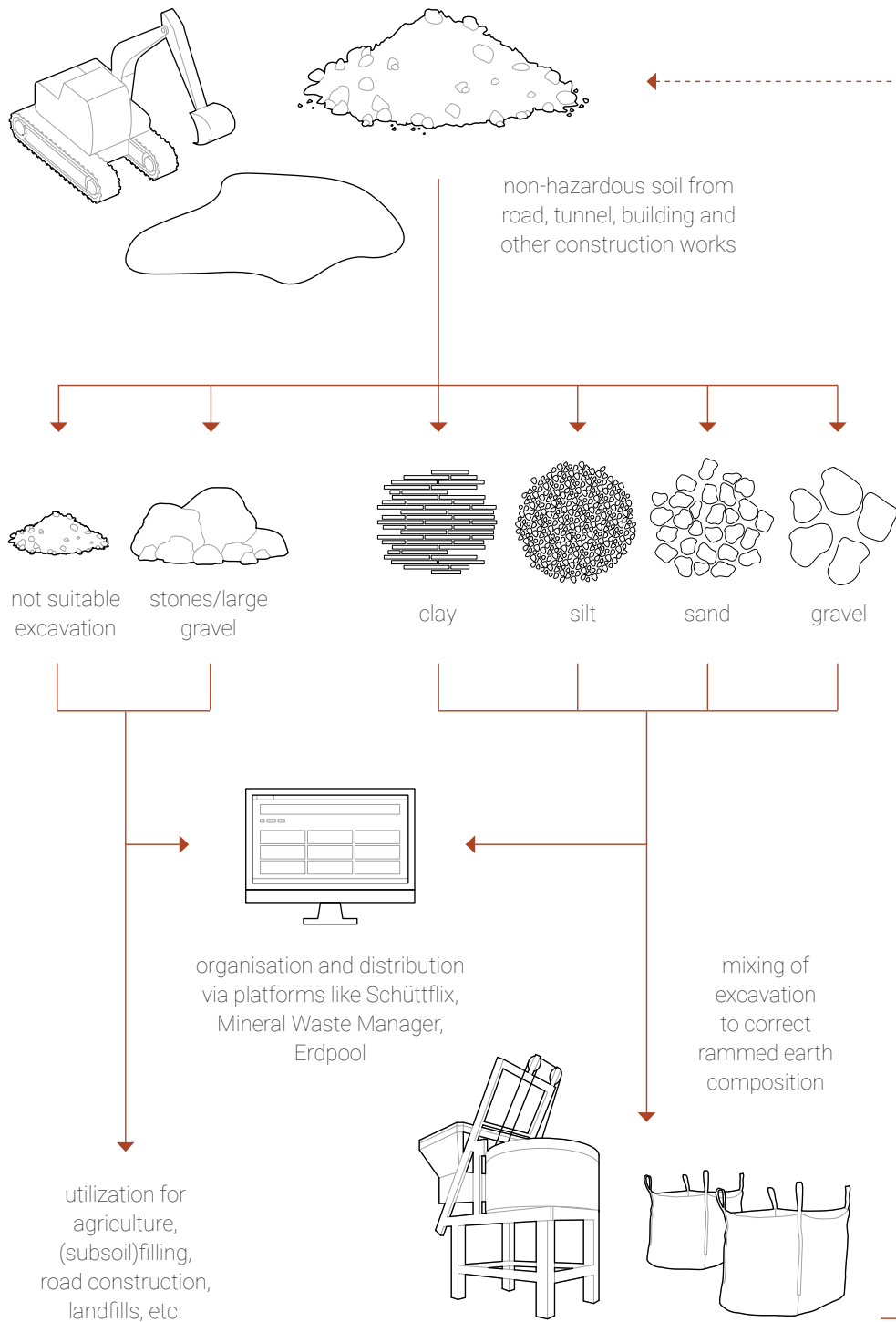

circular use of the material

possible applications in a prefabricated module with typical residential dimensions

rectangular wall elements for large continuous surfaces

production with (semi-)automated masonry units

smaller elements of a more complex shape, e.g. for facade surfaces

production with seven-axis robots

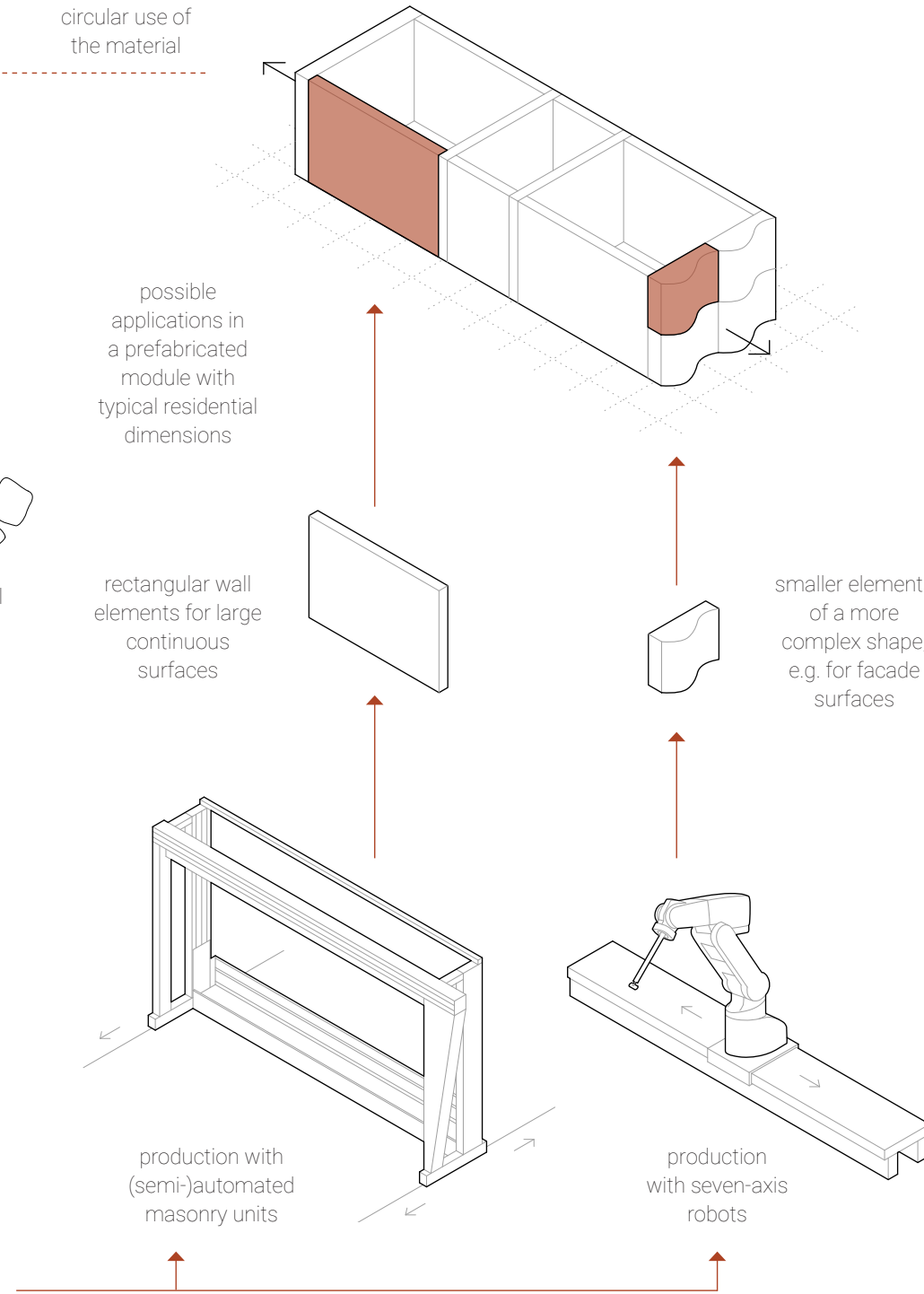

Problem Statement

Research

Implementation

Urban Scale

Building Scale

Recap



Infrastructure Masonry Elements Germany

Problem Statement

Research



Implementation

Urban Scale

Building Scale

Recap

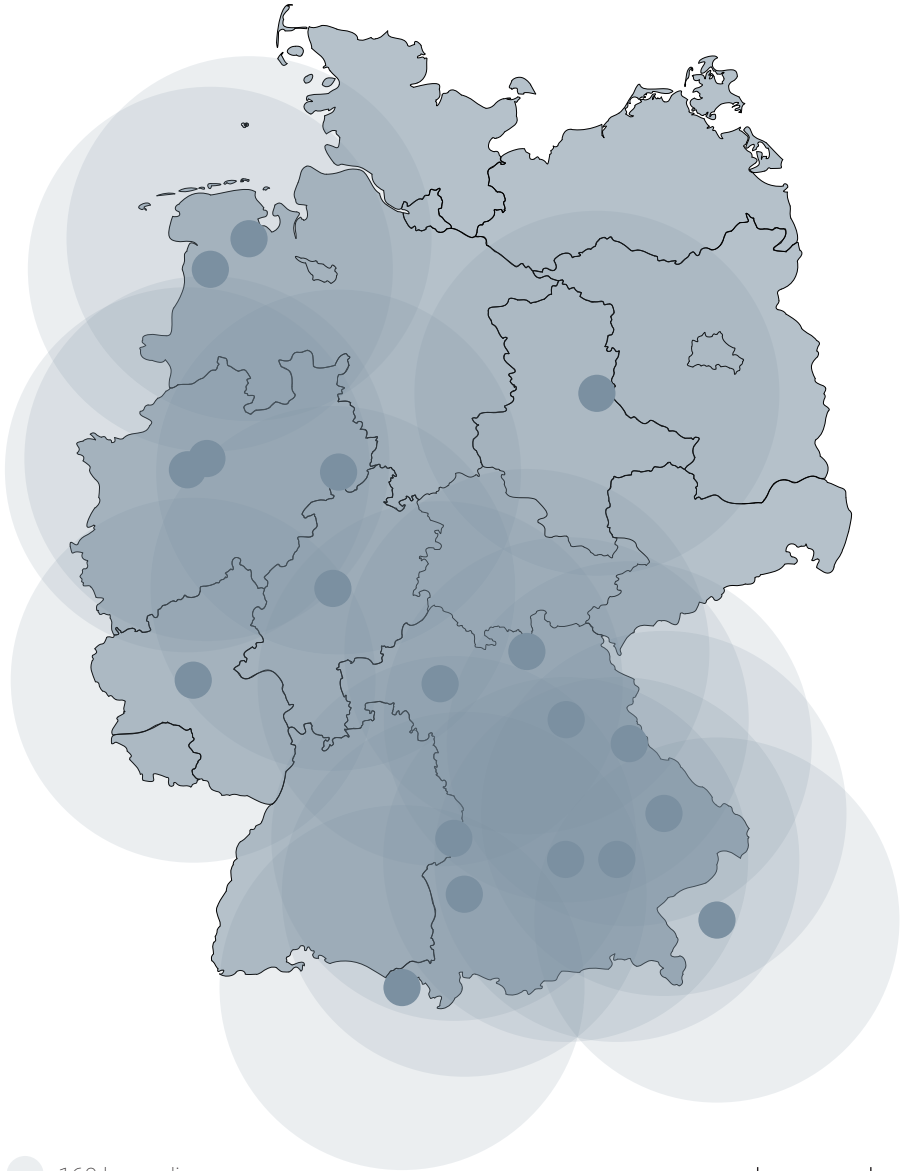

160 km radius
possible production sites



Application of Research

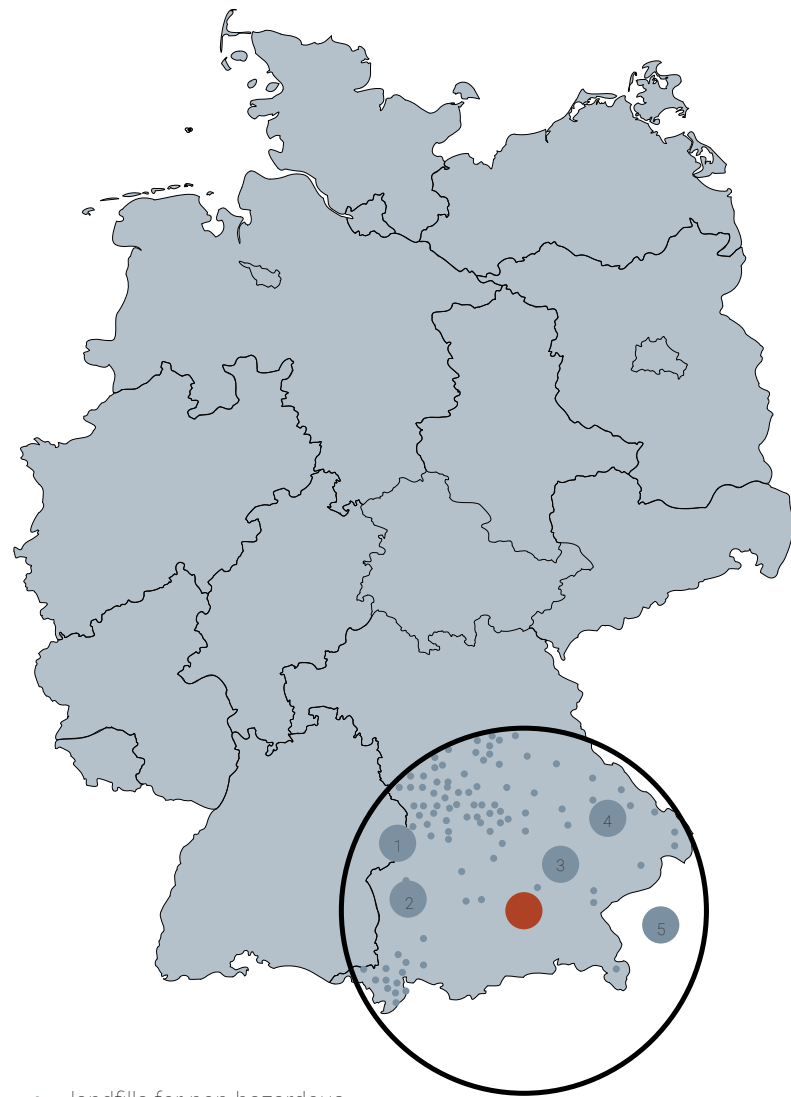

• landfills for non-hazardous soil excavations (DK0, estimation for 2013)

● possible production sites

● building site in Neuperlach, Munich (DE)



1 RIFFEL BAU & FERTIGTEILE GmbH

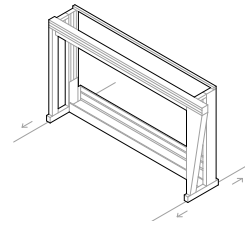

2 Otto Staudacher Vertriebs GmbH

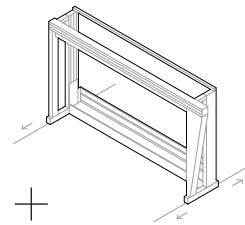

3 Thalhammer Rudolf GmbH

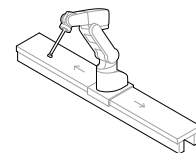

4 Redbloc Elemente GmbH - Werk Plattling

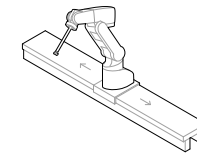
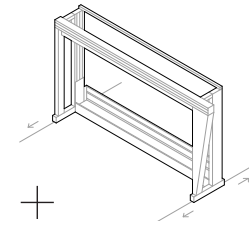

5 Redbloc Nord Ziegelfertigteil

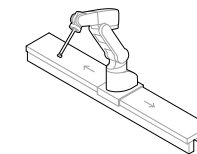
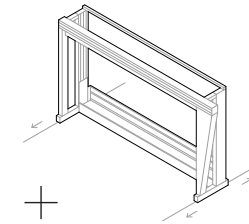

Problem Statement

Research

Implementation

Urban Scale

Building Scale

Recap



Predominantly Clayey Soils

Problem Statement

Research



Implementation

Urban Scale

Building Scale

Recap

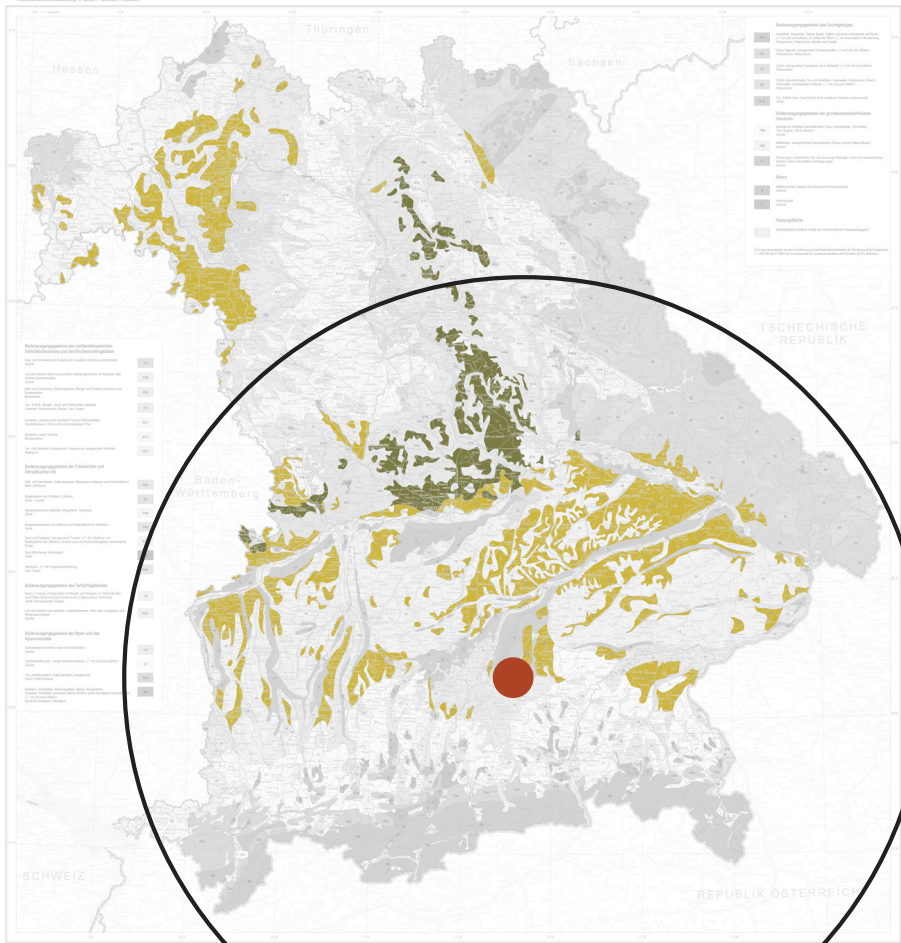

- Loess and loess clay over tertiary loose sediments, rarely over jurassic rocks and giant ejecta
- Residual loam/clay (able clay), loess clay
- building site in Neuperlach, Munich (DE)



Let's build a landfill!

or: How can we turn non-hazardous soil excavations into buildings?

What?

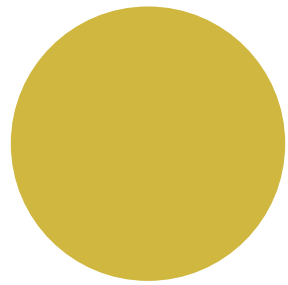

Implementation

Column - Floor System

Problem Statement

Research

Implementation



Urban Scale

Building Scale

Recap

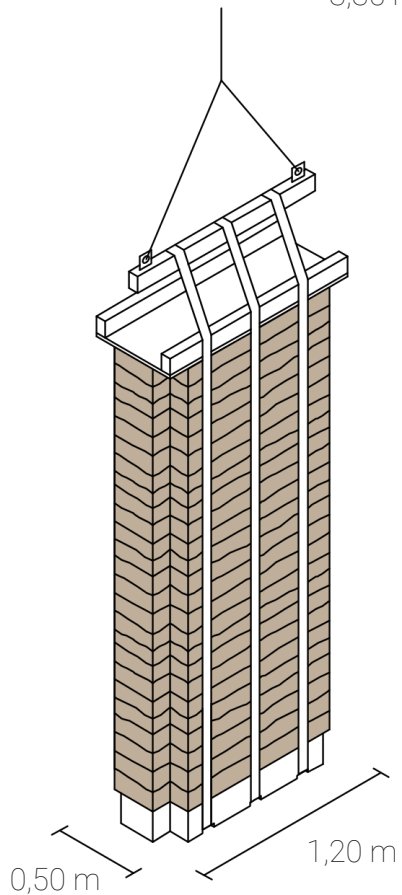
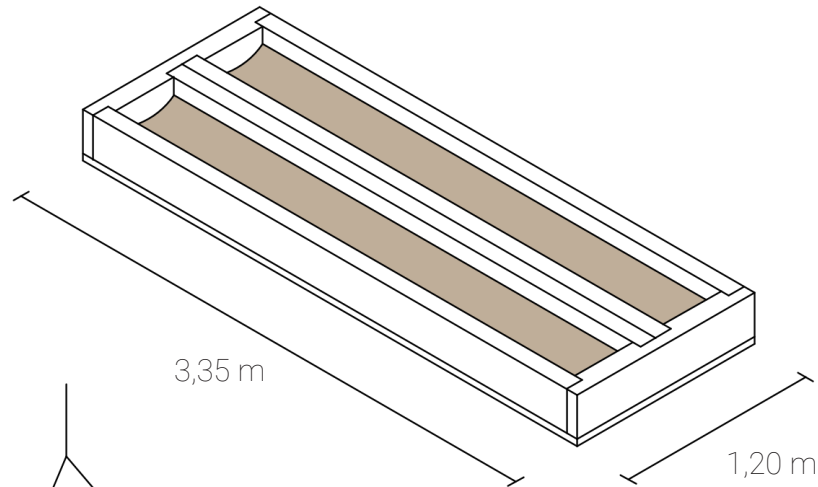

Total Stampflehm

4'061 kg
1.73 m³



Eingespartes Deponievolumen

2.70 m³



CO₂-Emission

78.780 kg CO₂ eq

Umweltbelastungspunkte

325'270 UBP



CLT Brettsperrholz

299.10 kg CO₂ eq + 280%
666'013 UBP + 105%



Stahlbeton
(mit 90kg Stahl/m³)

637.80 kg CO₂ eq + 710%
1'067'731 UBP + 228%

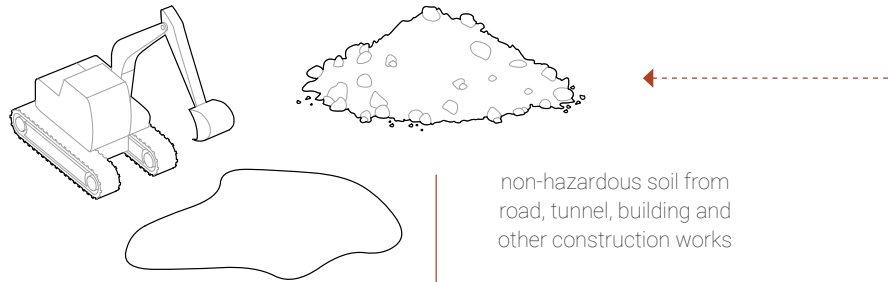

circular use of the material

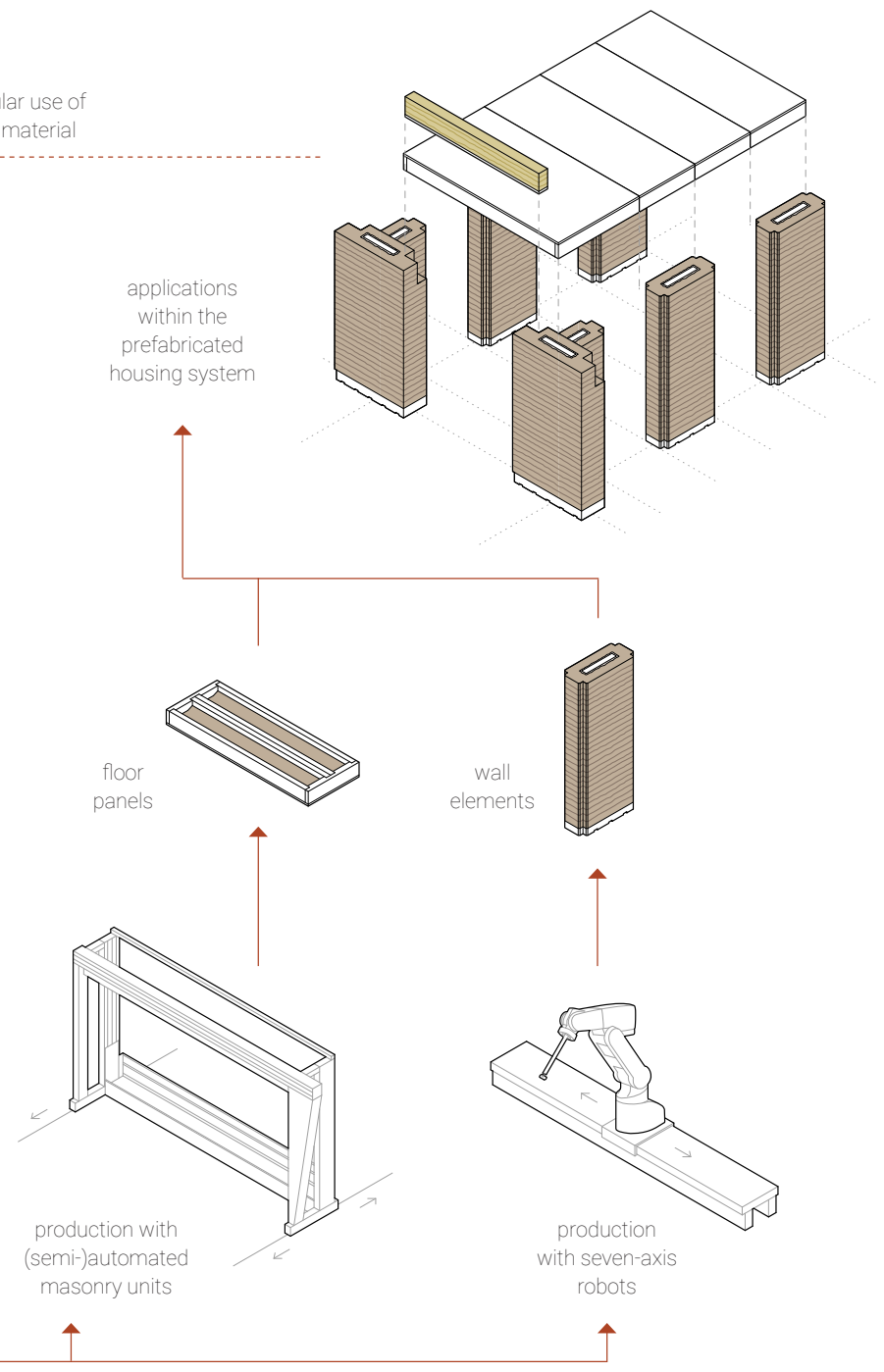
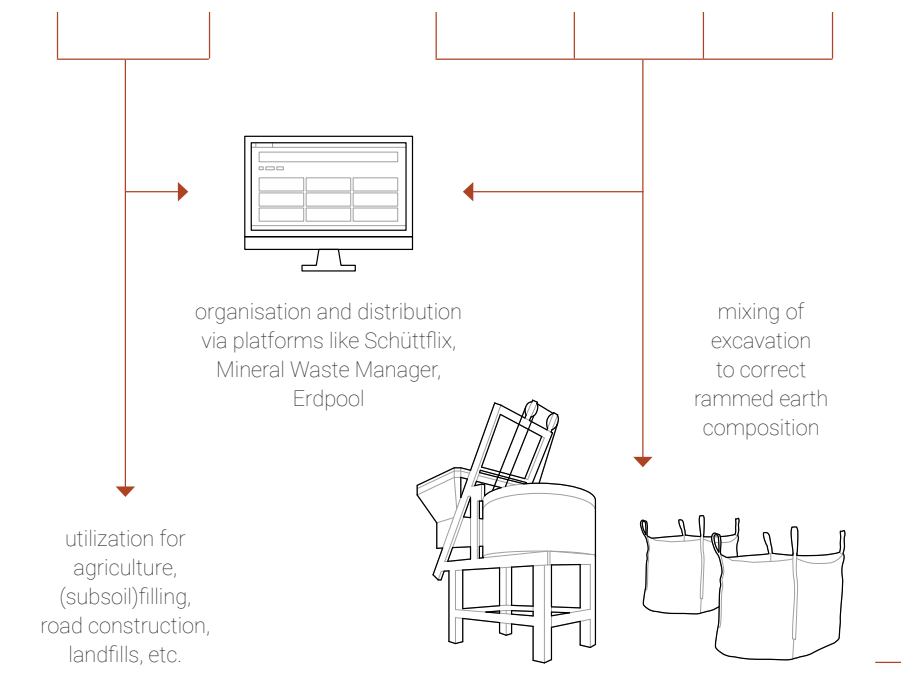
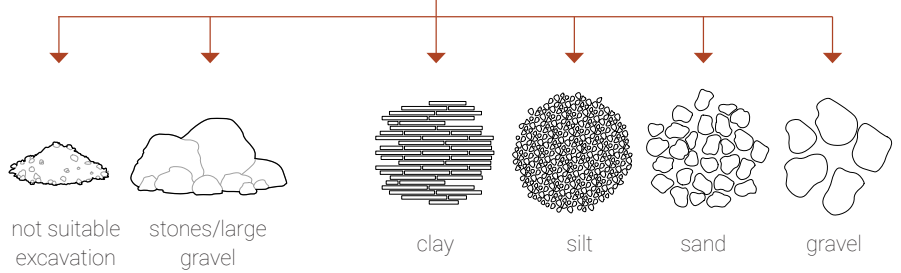

- Problem Statement
- Research
- Implementation**
- Urban Scale
- Building Scale
- Recap



Problem Statement

Research

Implementation



Urban Scale

Building Scale

Recap

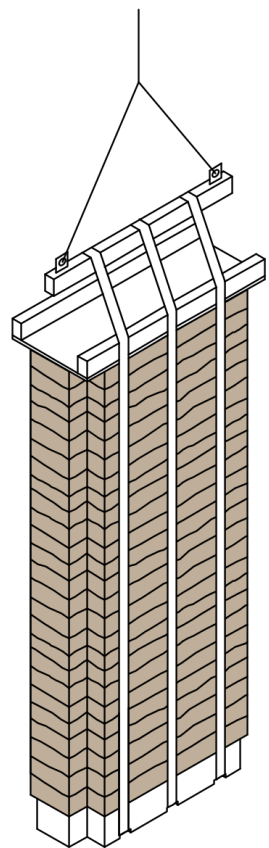

Problem Statement

Research

Implementation

Urban Scale

Building Scale

Recap

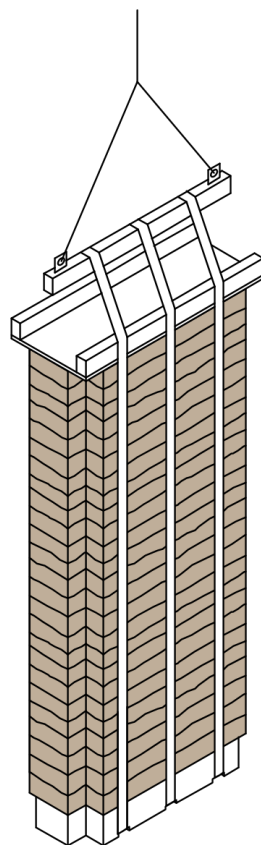
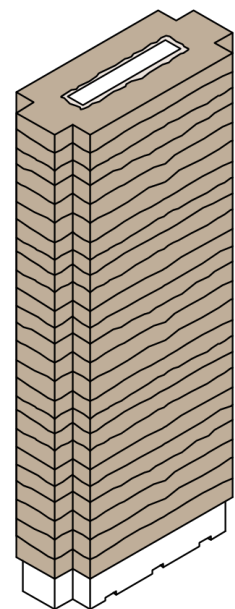

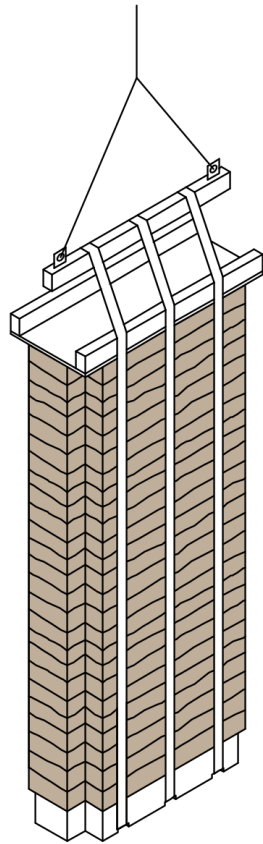
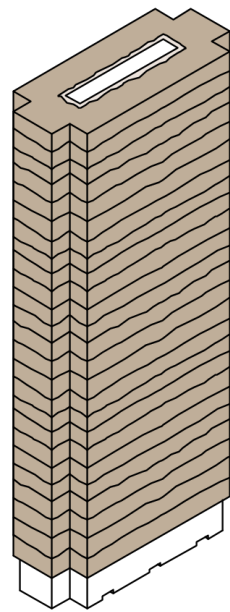
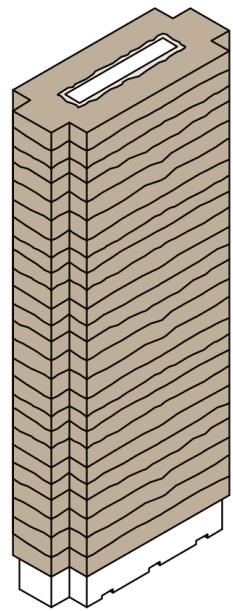

Problem
Statement

Research

Implementation



Urban Scale

Building Scale

Recap

Problem Statement

Research

Implementation



Urban Scale

Building Scale

Recap

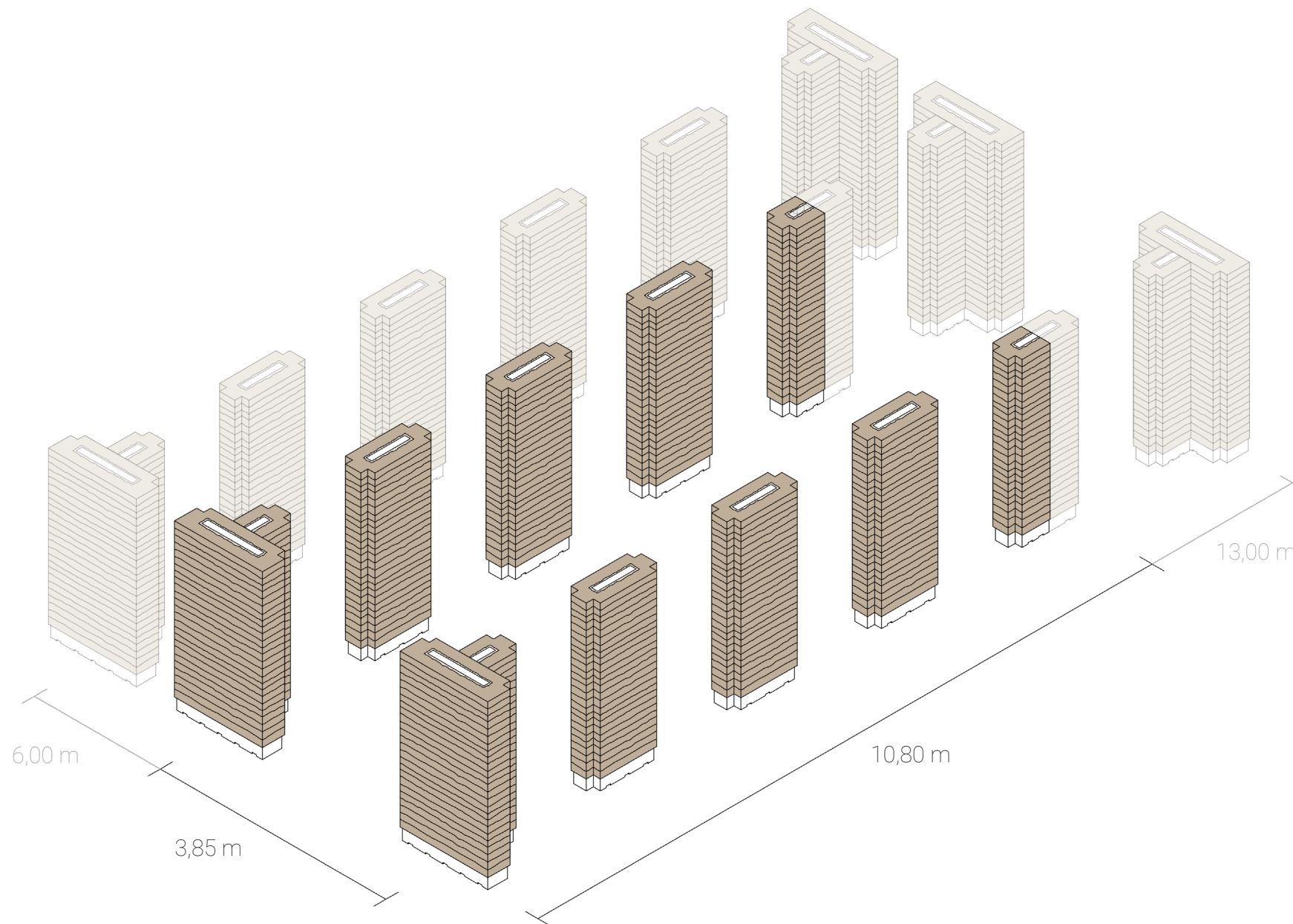

Problem Statement

Research

Implementation



Urban Scale

Building Scale

Recap

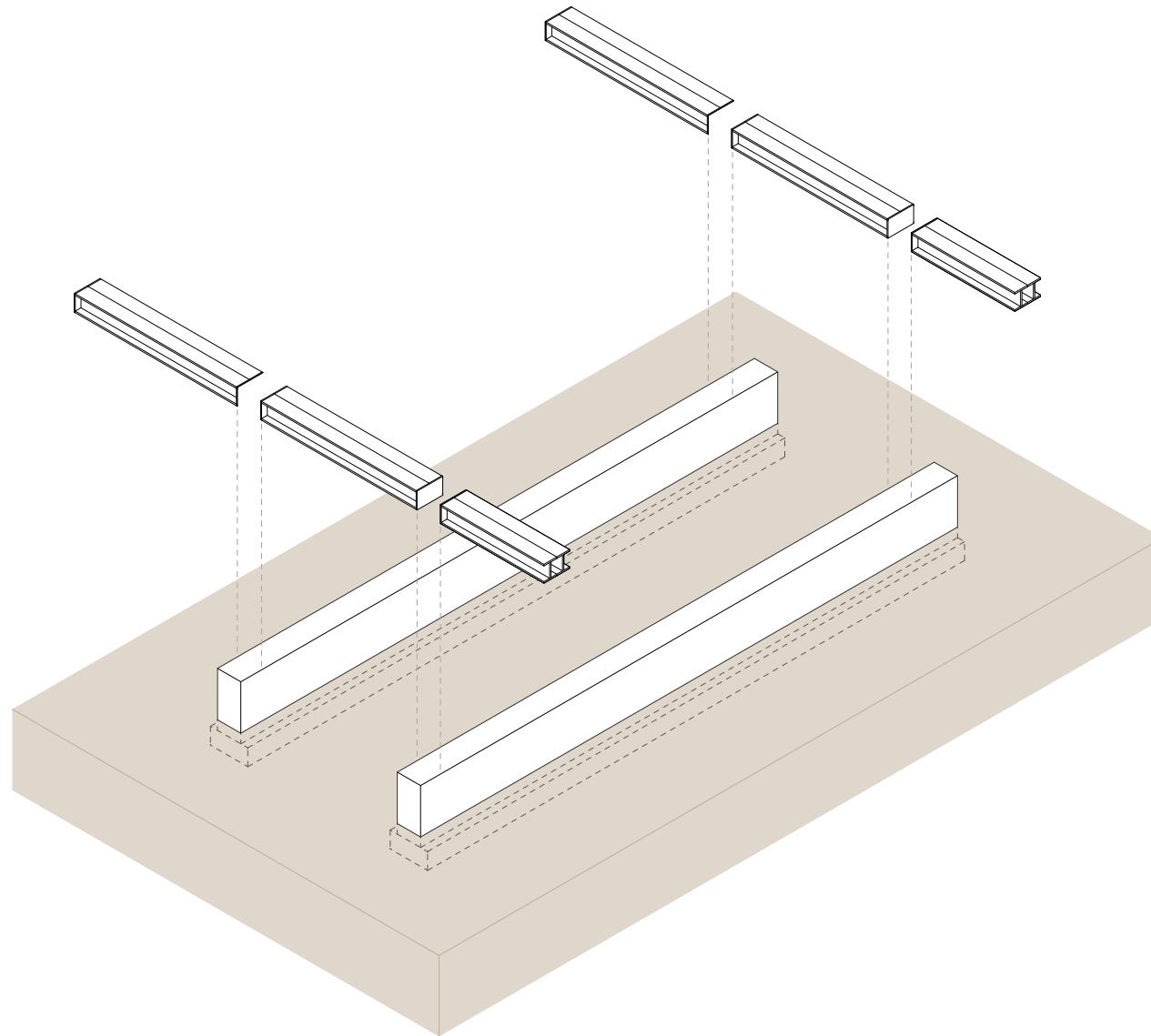

Problem
Statement

Research

Implementation



Urban Scale

Building Scale

Recap

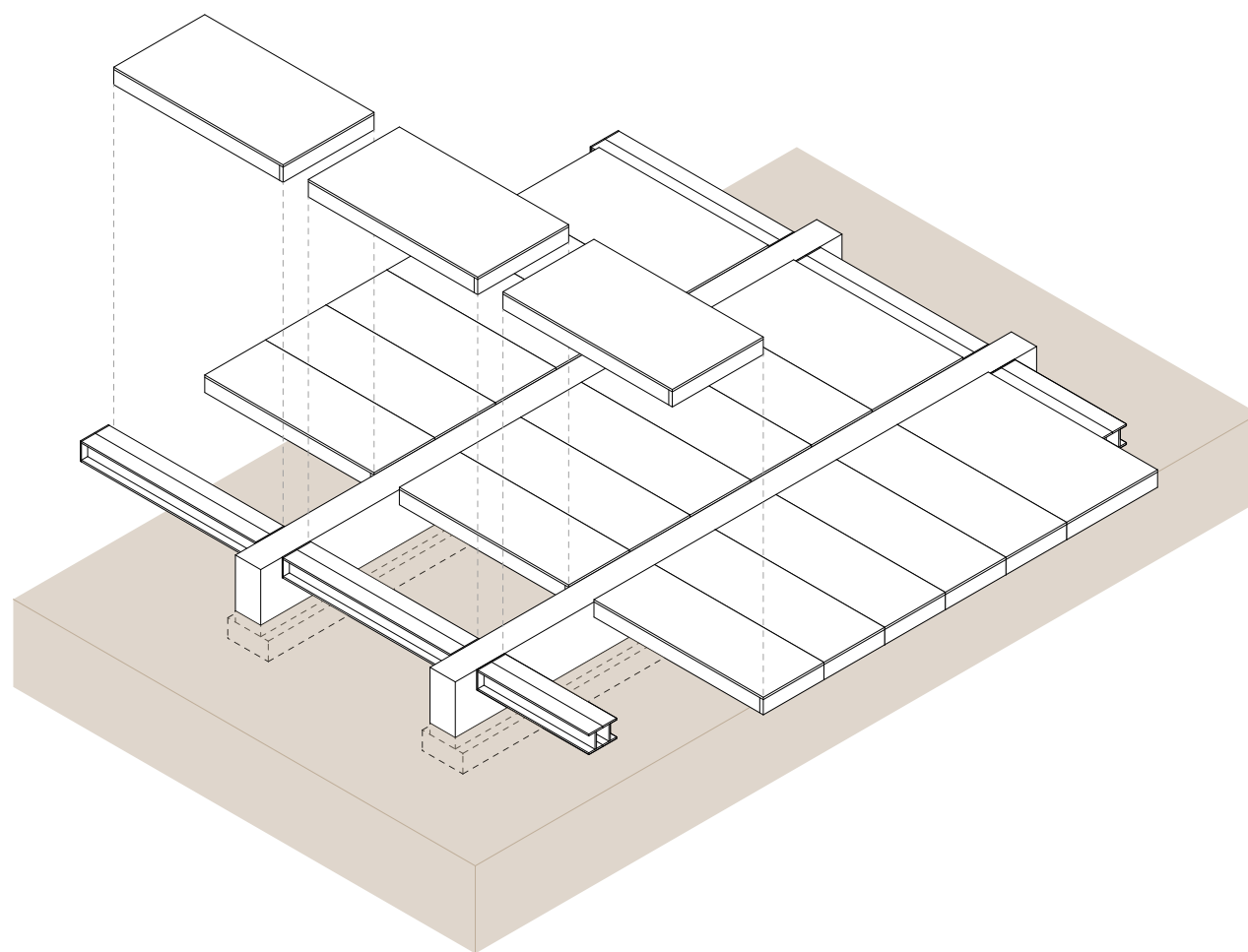

Problem
Statement

Research

Implementation



Urban Scale

Building Scale

Recap

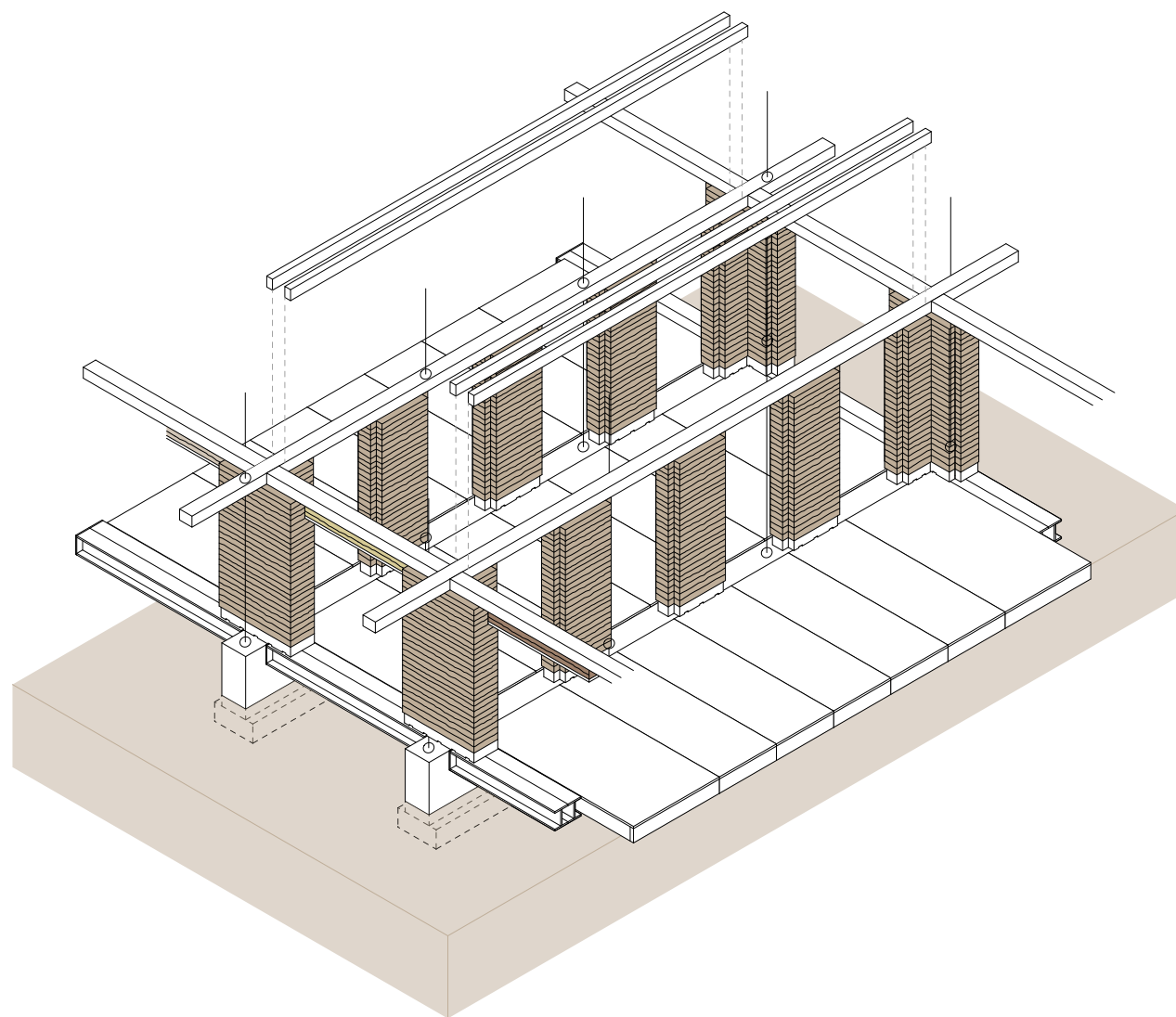

Problem
Statement

Research

Implementation



Urban Scale

Building Scale

Recap

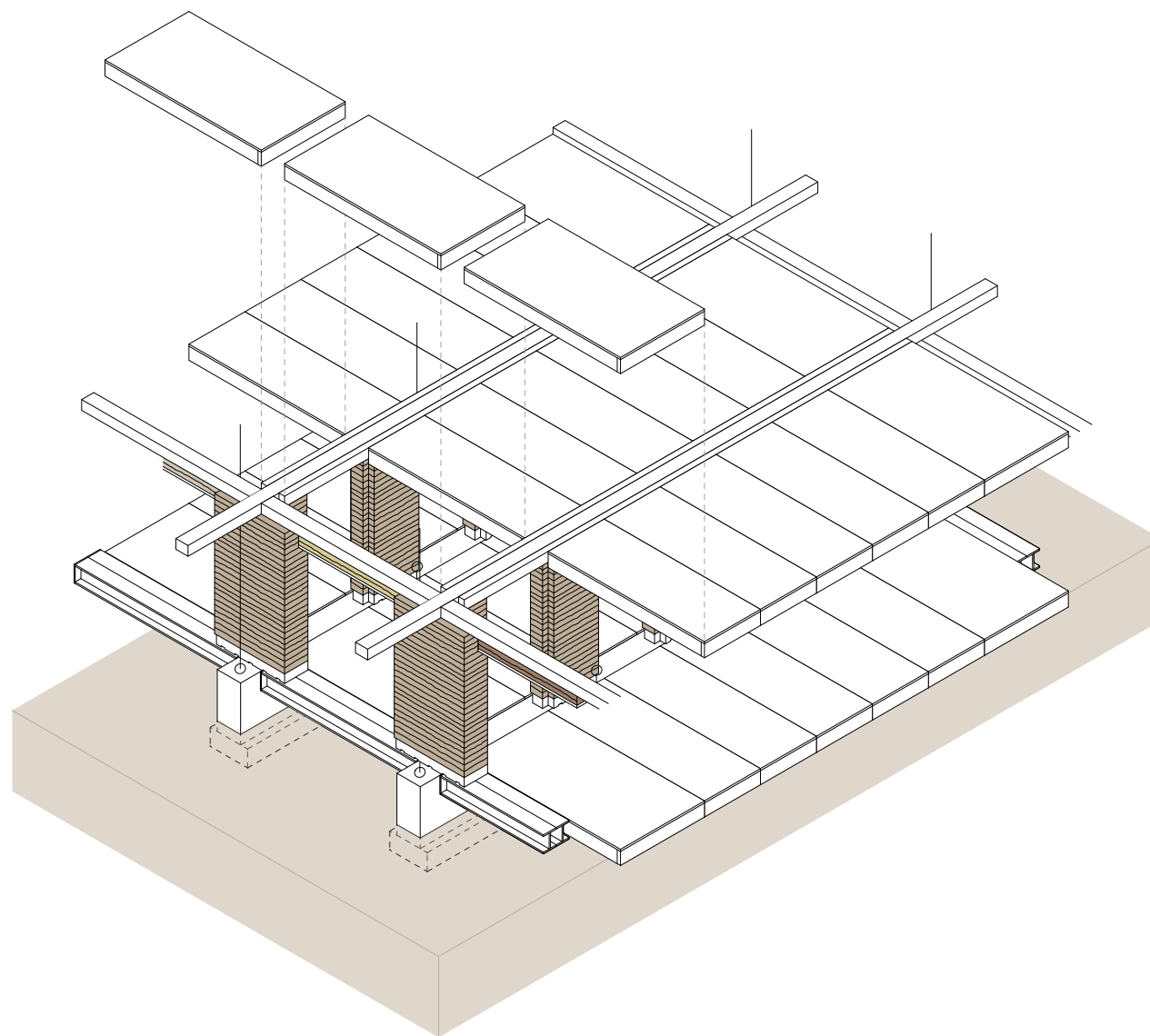

Problem
Statement

Research

Implementation



Urban Scale

Building Scale

Recap

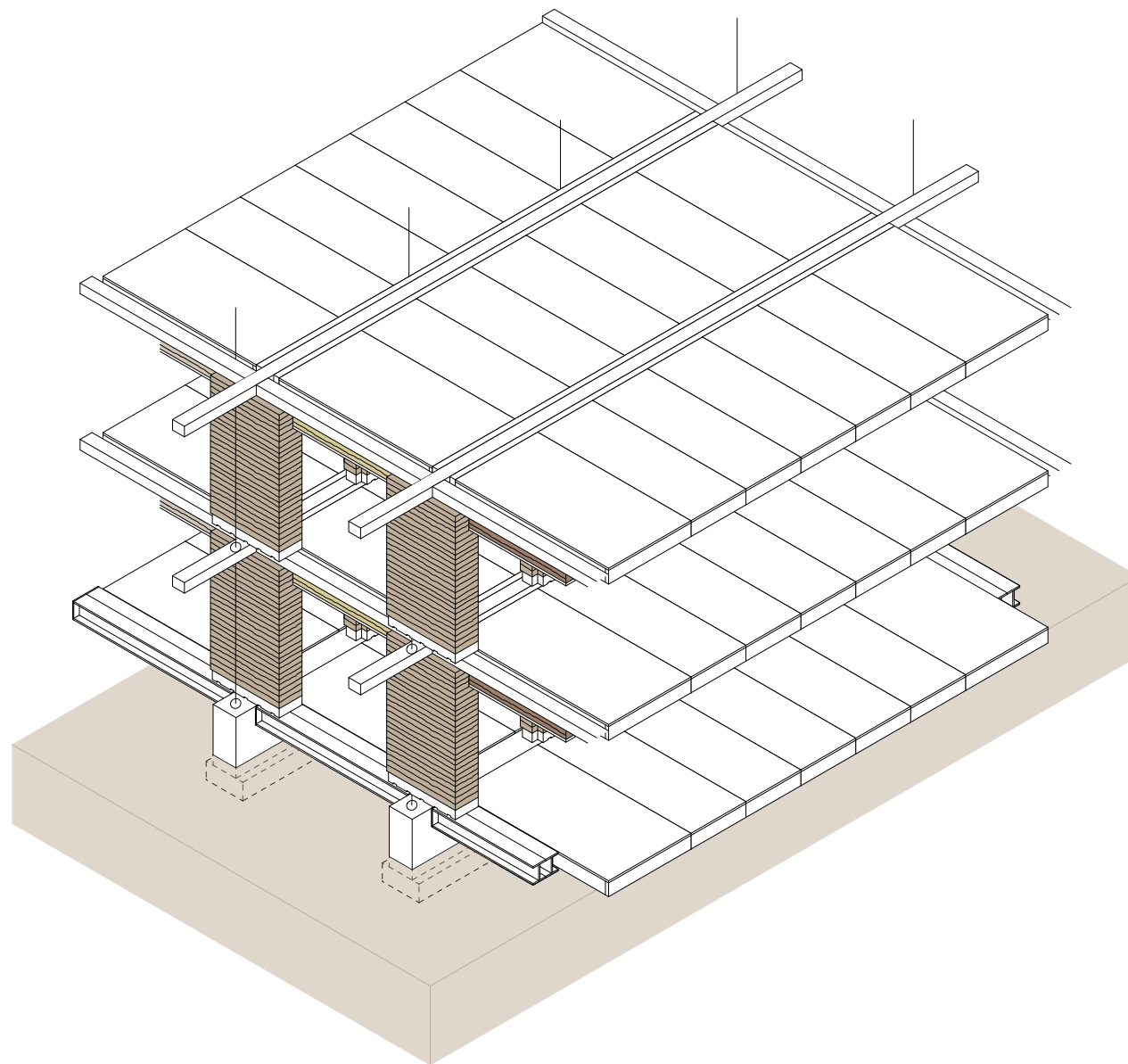

Floorplan Schemes 64m² Apartment

Problem Statement

Research

Implementation



Urban Scale

Building Scale

Recap

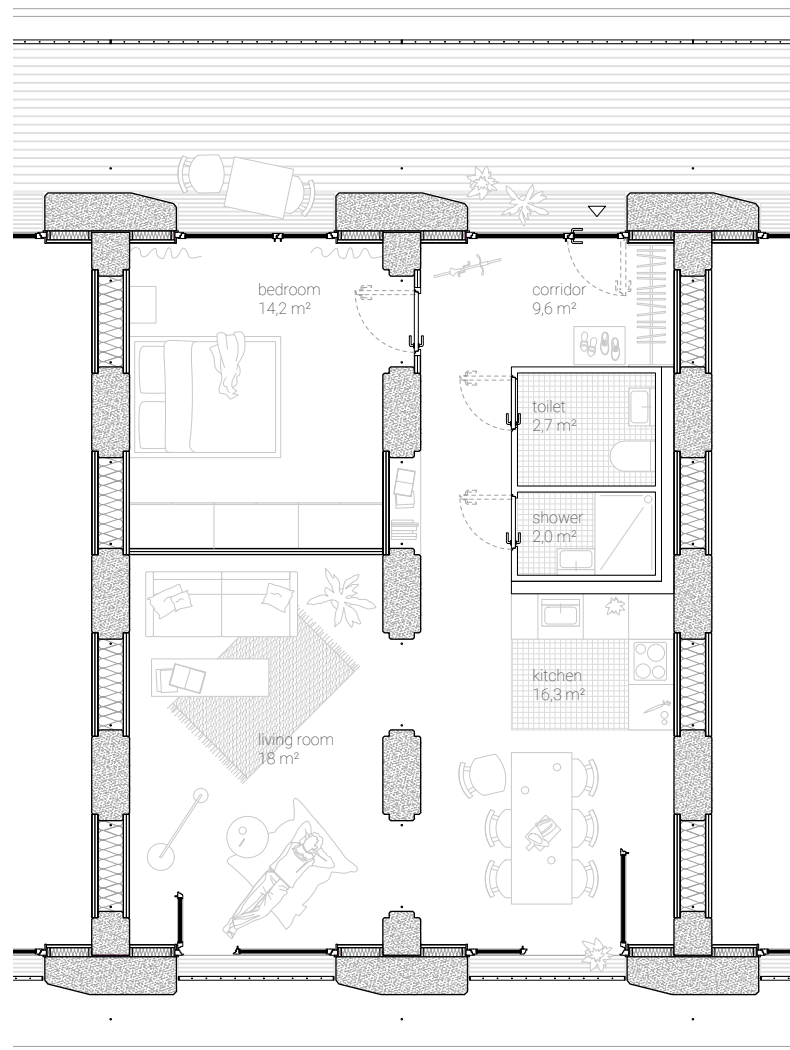

Exemplary floor plan

1:100



Floorplan Schemes 64m² Apartment

Problem Statement

Research

Implementation



Urban Scale

Building Scale

Recap

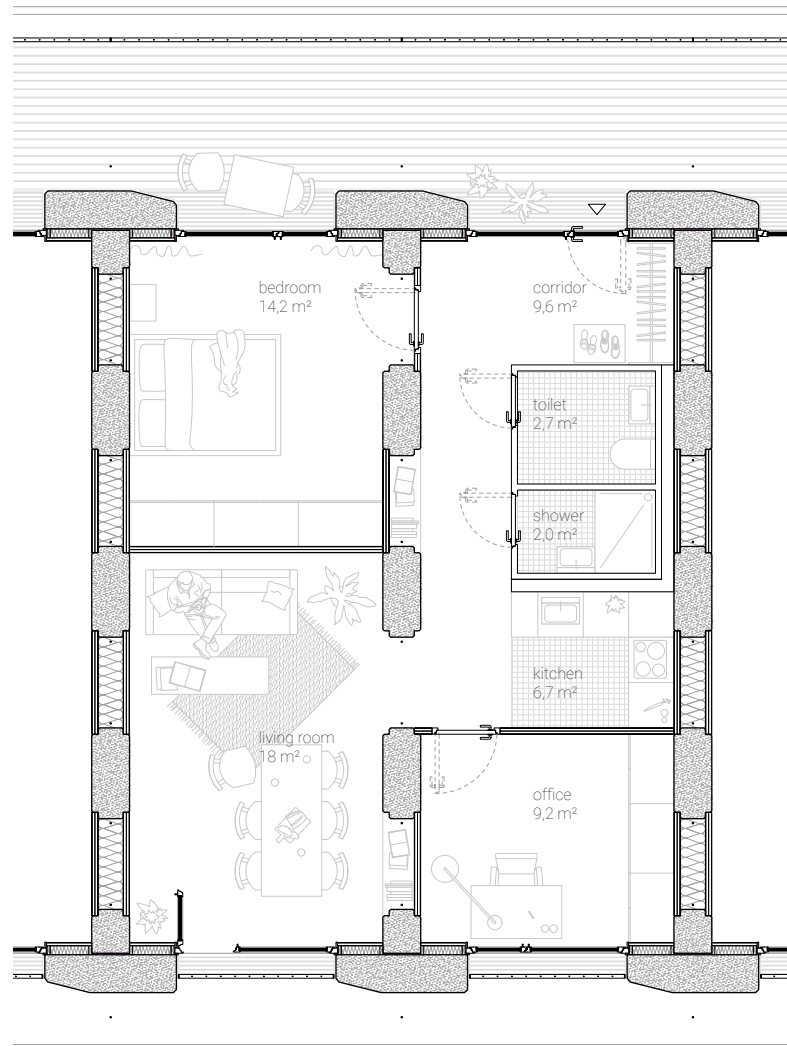

Floorplan Schemes 96m2 Apartment

Problem Statement

Research

Implementation



Urban Scale

Building Scale

Recap

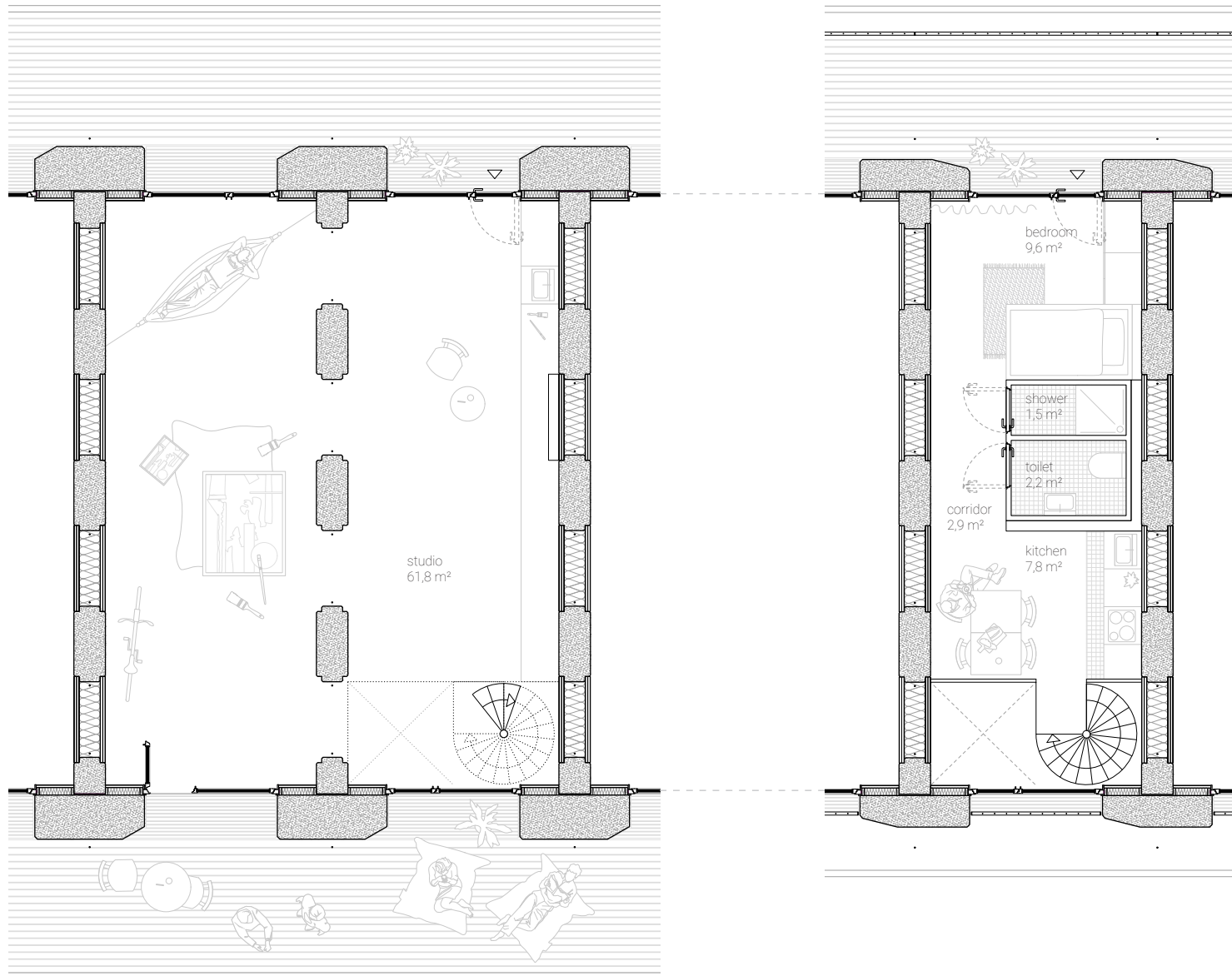

Floorplan Schemes 118m² Apartment

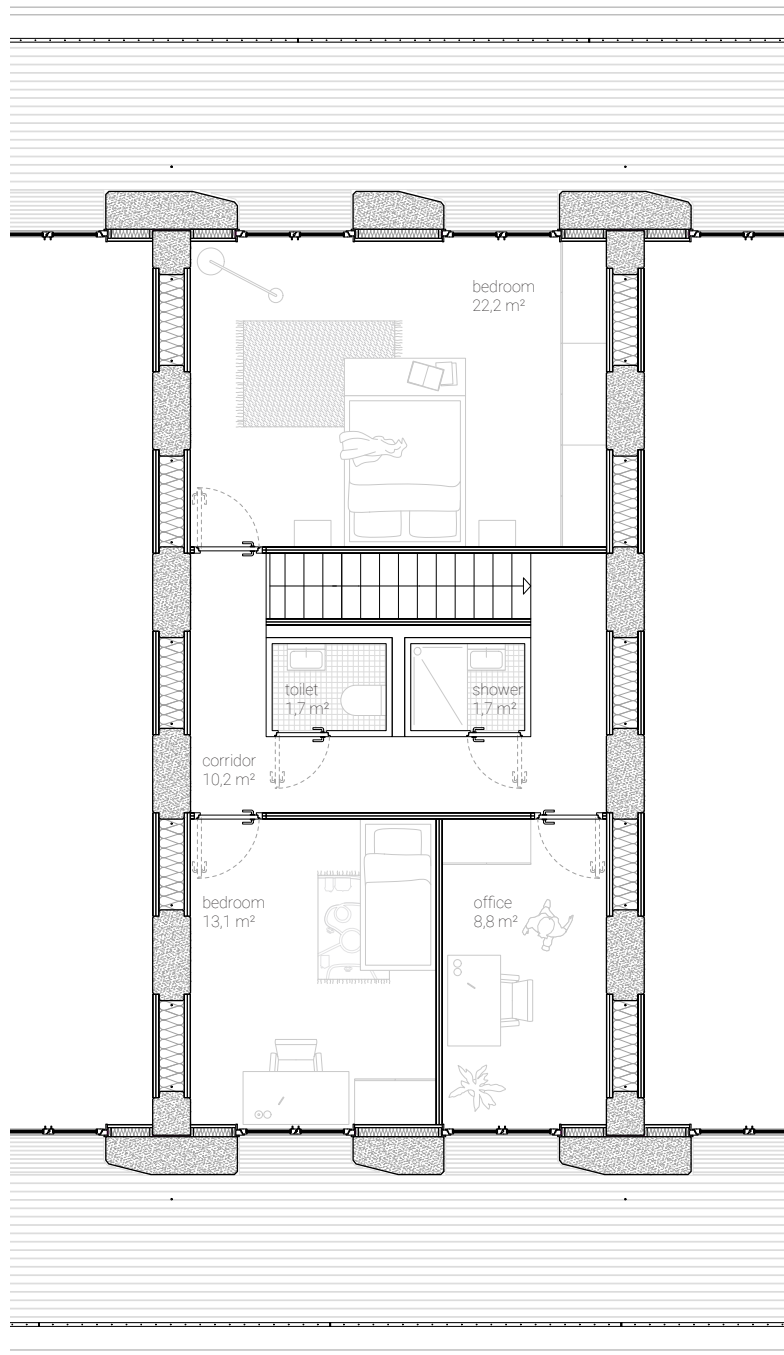

Problem Statement

Research

Implementation



Urban Scale

Building Scale

Recap

Floorplan Schemes 118m² Apartment

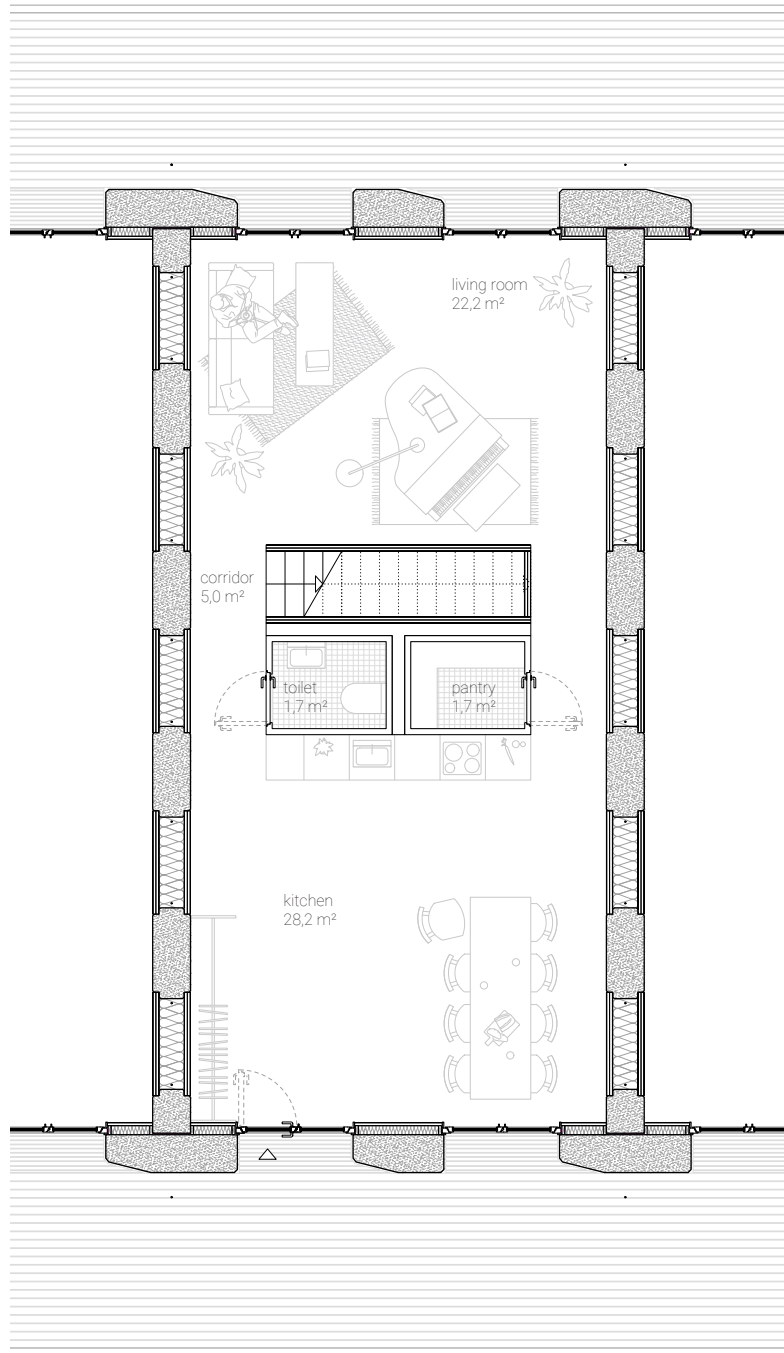

Problem
Statement

Research

Implementation



Urban Scale

Building Scale

Recap

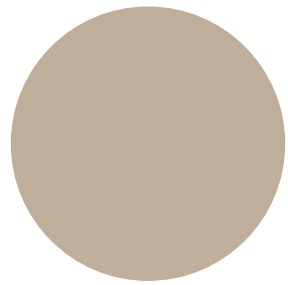

Urban Scale

Neuperlach, Munich (DE)



Problem Statement

Research

Implementation

Urban Scale

Building Scale

Recap

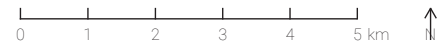

High-Income Households (> 4000€/Month) 2015

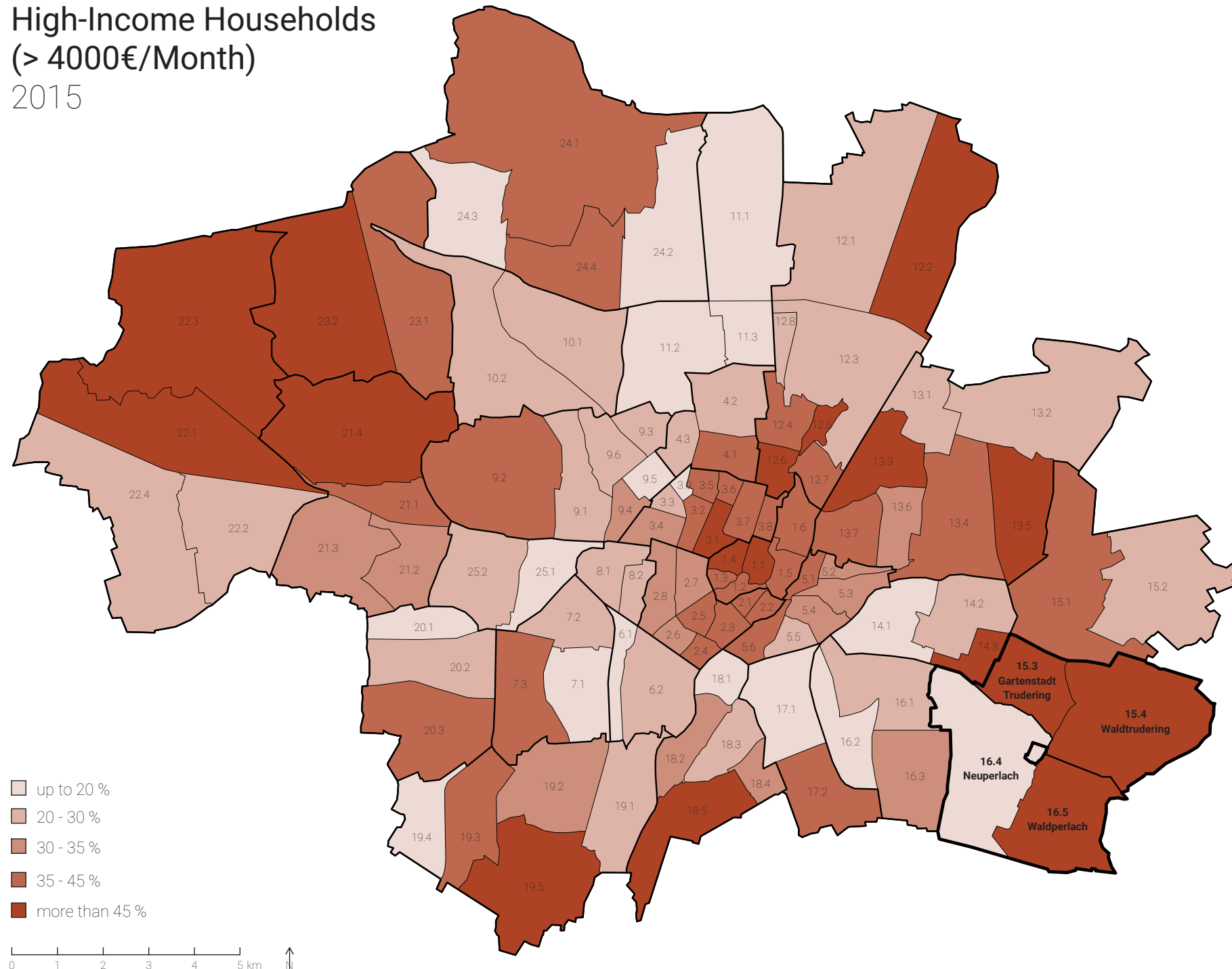

- Problem Statement
- Research
- Implementation
- Urban Scale** ●
- Building Scale
- Recap

- 1 Altstadt - Lehel
- 2 Ludwigsvorstadt - Isarvorstadt
- 3 Maxvorstadt
- 4 Schwabing - West
- 5 Au - Haidhausen
- 6 Sendling
- 7 Sendling - Westpark
- 8 Schwanthalerhöhe
- 9 Neuhausen - Nymphenburg
- 10 Moosach
- 11 Milbertshofen - Am Hart
- 12 Schwabing - Freimann
- 13 Bogenhausen
- 14 Berg am Laim
- 15 Trudering - Riem**
- 16 Ramersdorf - Perlach**
- 17 Obergiesing - Fasangarten
- 18 Untergiesing - Harlaching
- 19 Thalkirchen - Obersendling - Forstenried - Fürstenried - Solln
- 20 Haidhausen
- 21 Pasing - Obermetzing
- 22 Aubing - Lochhausen - Langwied
- 23 Allach - Untermenzing
- 24 Feldmoching - Hasenbergl
- 25 Laim

Heights of Buildings

Problem Statement

Research

Implementation

Urban Scale

Building Scale

Recap

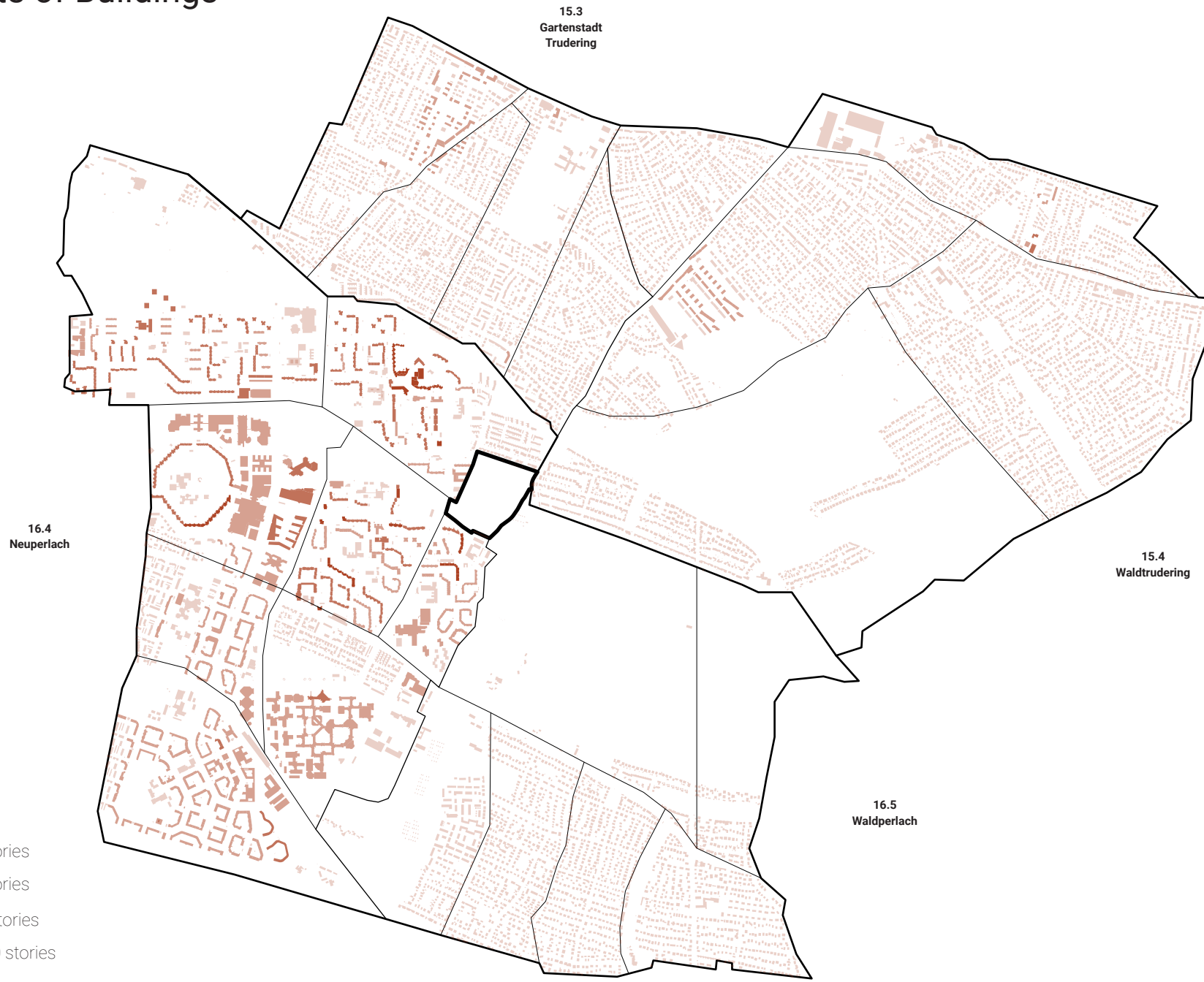

- 1 to 3 stories
- 4 to 6 stories
- 7 to 10 stories
- above 10 stories

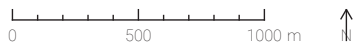



Northern view



Eastern view



Southern view



Western view

Problem Statement

Research

Implementation

Urban Scale



Building Scale

Recap

District and Neighbourhood Centres



Public Functions



Problem Statement

Research

Implementation

Urban Scale

Building Scale

Recap



Urban Design





- Problem Statement
- Research
- Implementation
- Urban Scale** ●
- Building Scale
- Recap



Traffic Scheme



all traffic allowed 
closed for private motorized vehicles 

- Problem Statement
- Research
- Implementation
- Urban Scale
- Building Scale** 
- Recap

Building Structures

Problem Statement

Research

Implementation

Urban Scale

Building Scale

Recap



special structures 

residential building system 

Landscaping Scheme

Problem Statement

Research

Implementation

Urban Scale

Building Scale

Recap

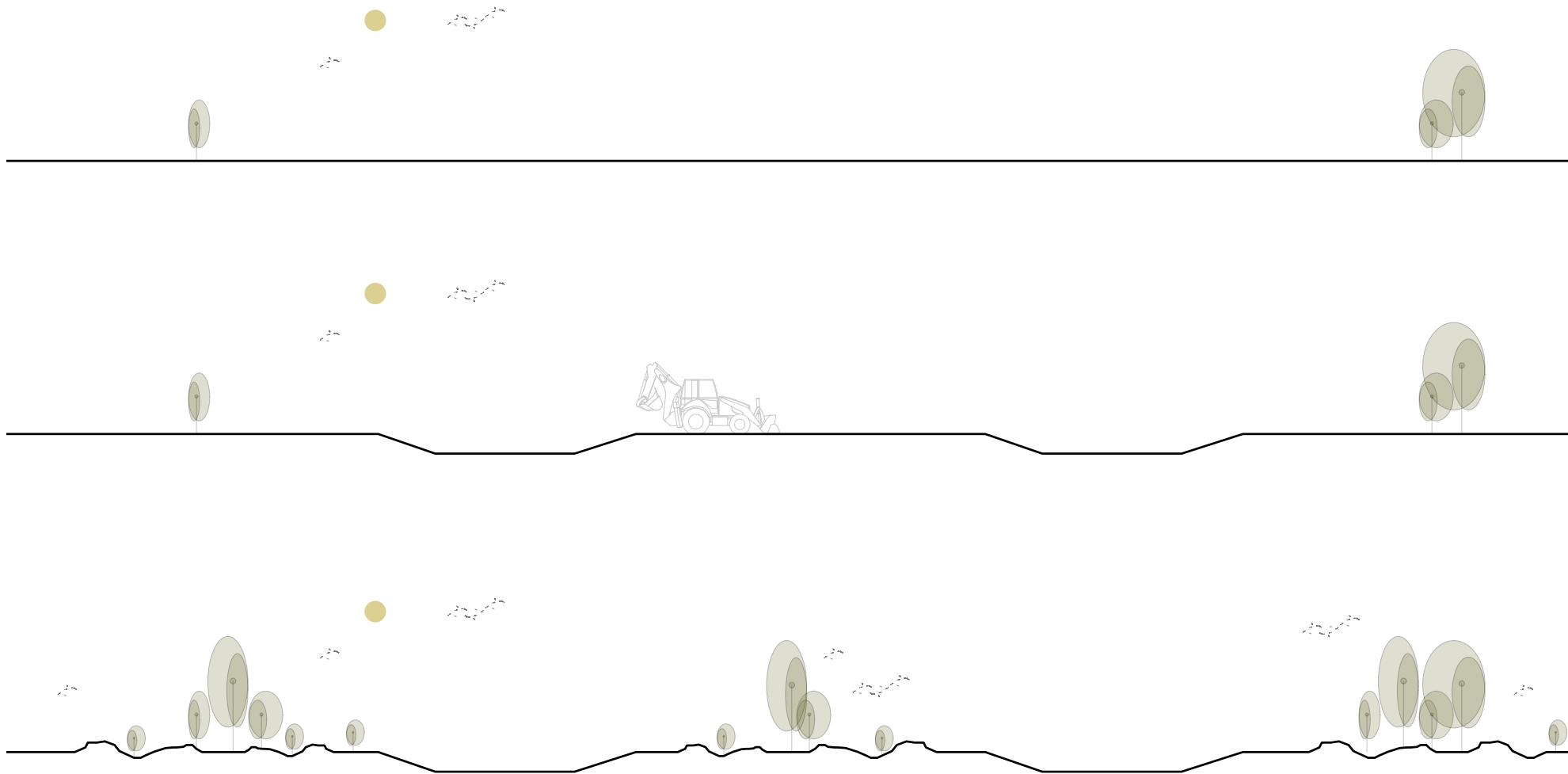

Chosen Plot



Problem Statement

Research

Implementation

Urban Scale

Building Scale



Recap



Axonometric view

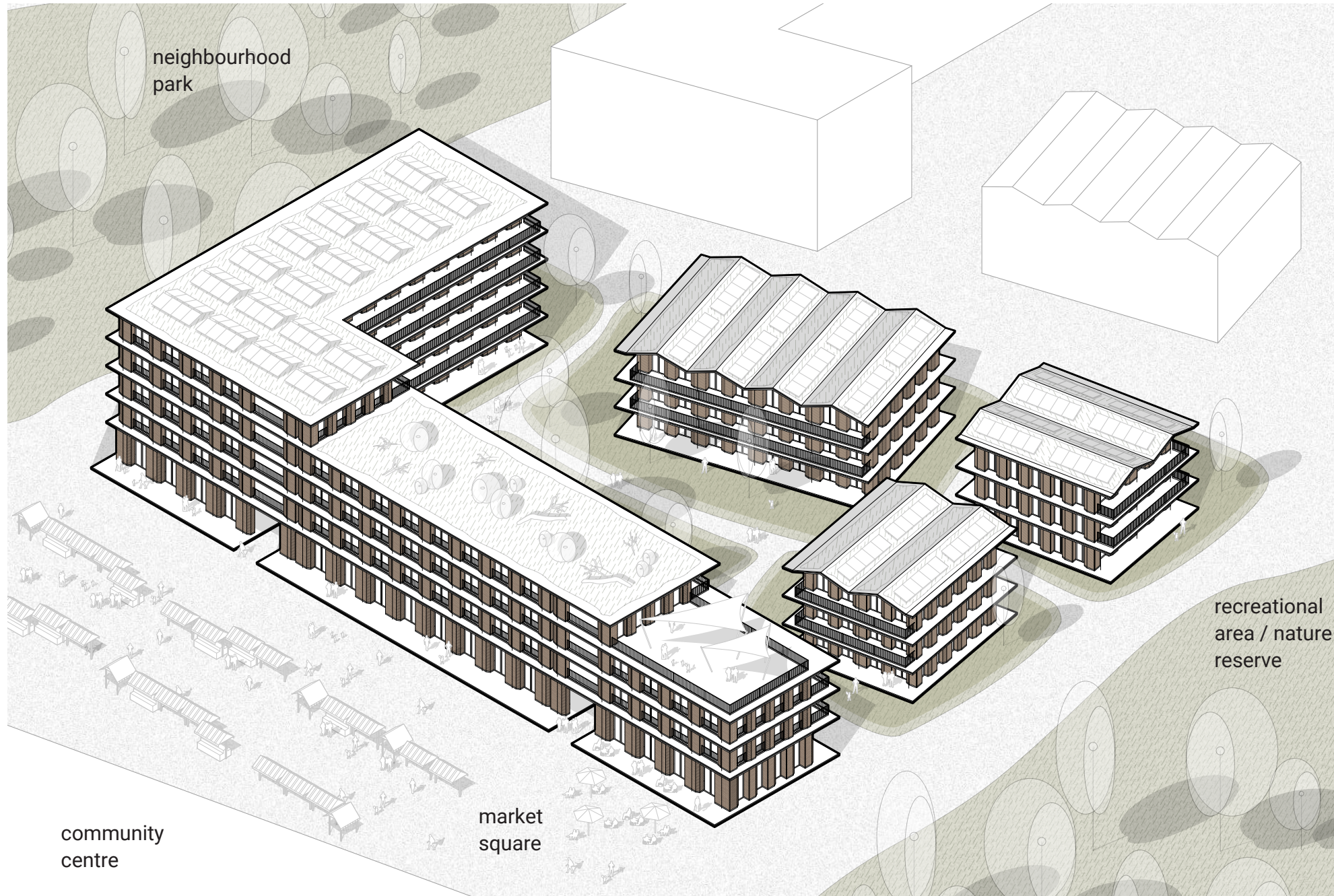

Problem Statement

Research

Implementation

Urban Scale

Building Scale

Recap



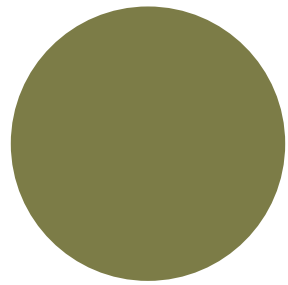

Building Scale

How does it work in a building?



- general building layout
- load bearing structure
- facade

Problem Statement

Research

Implementation

Urban Scale

Building Scale

Recap

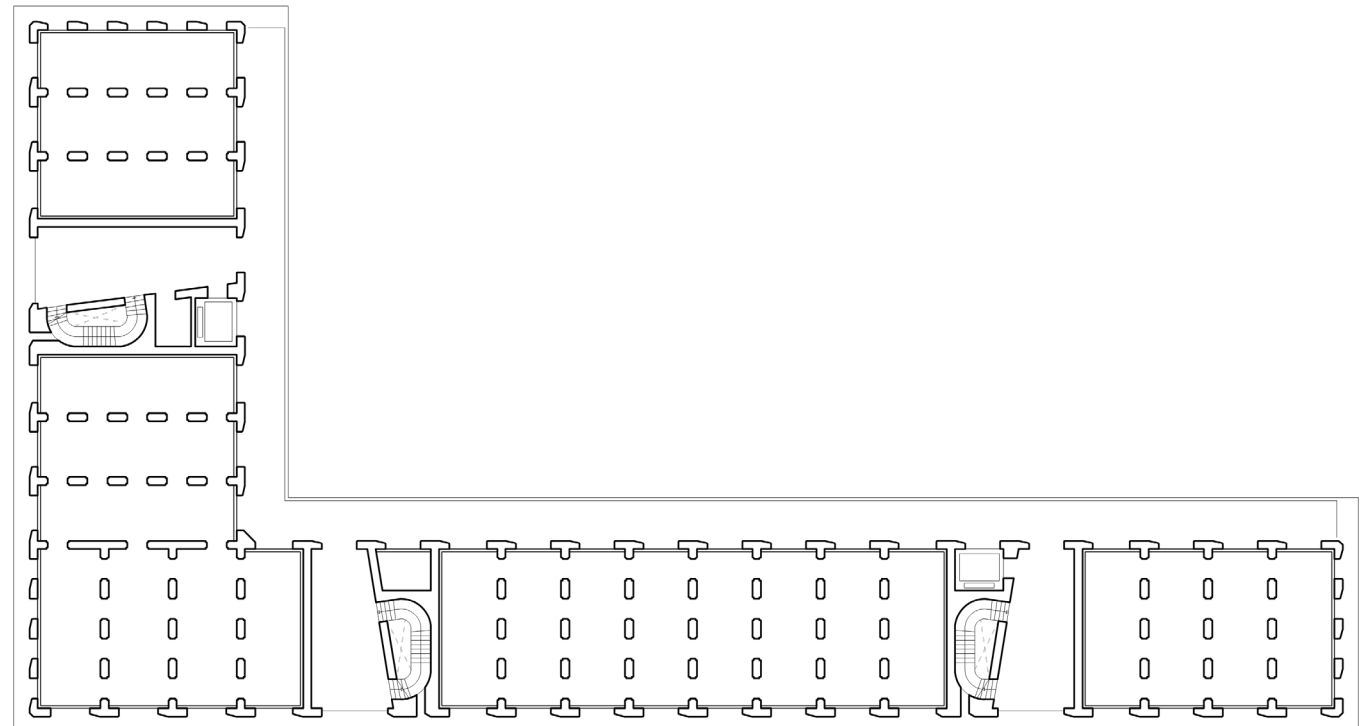

How does it work in a building?

designer

- general building layout
- load bearing structure
- facade

client

- division into clustered rental / individually owned units

Problem Statement

Research

Implementation

Urban Scale

Building Scale

Recap

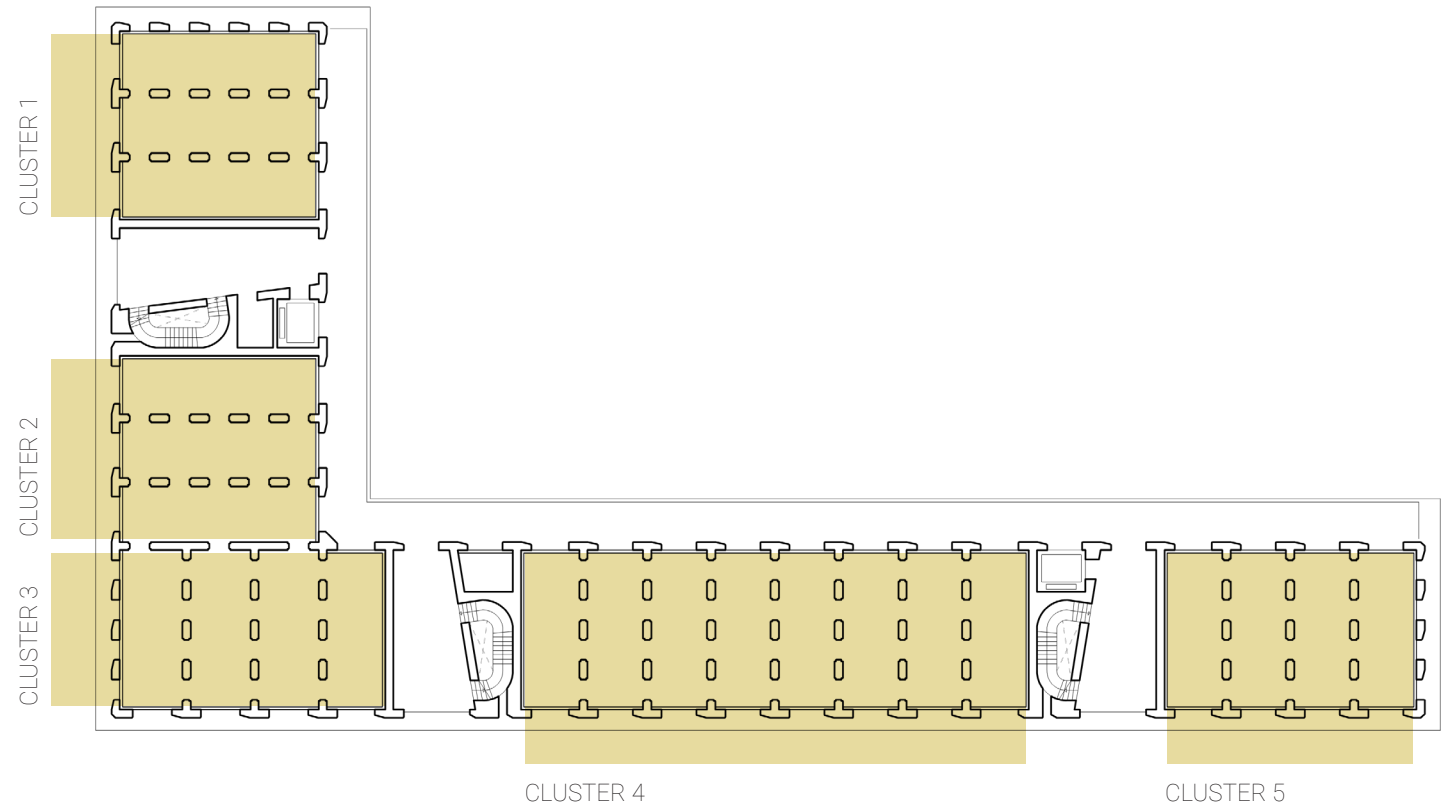

How does it work in a building?

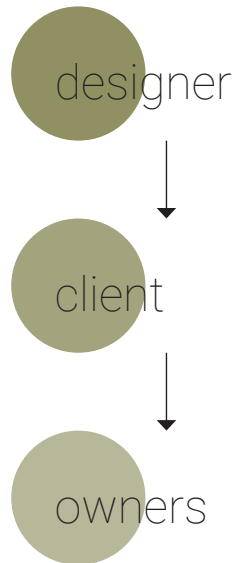

- general building layout
- load bearing structure
- facade

- division into clustered rental / individually owned units

- determination of unit sizes
- equipment of prefabricated bathroom / kitchen cells

Problem Statement

Research

Implementation

Urban Scale

Building Scale



Recap

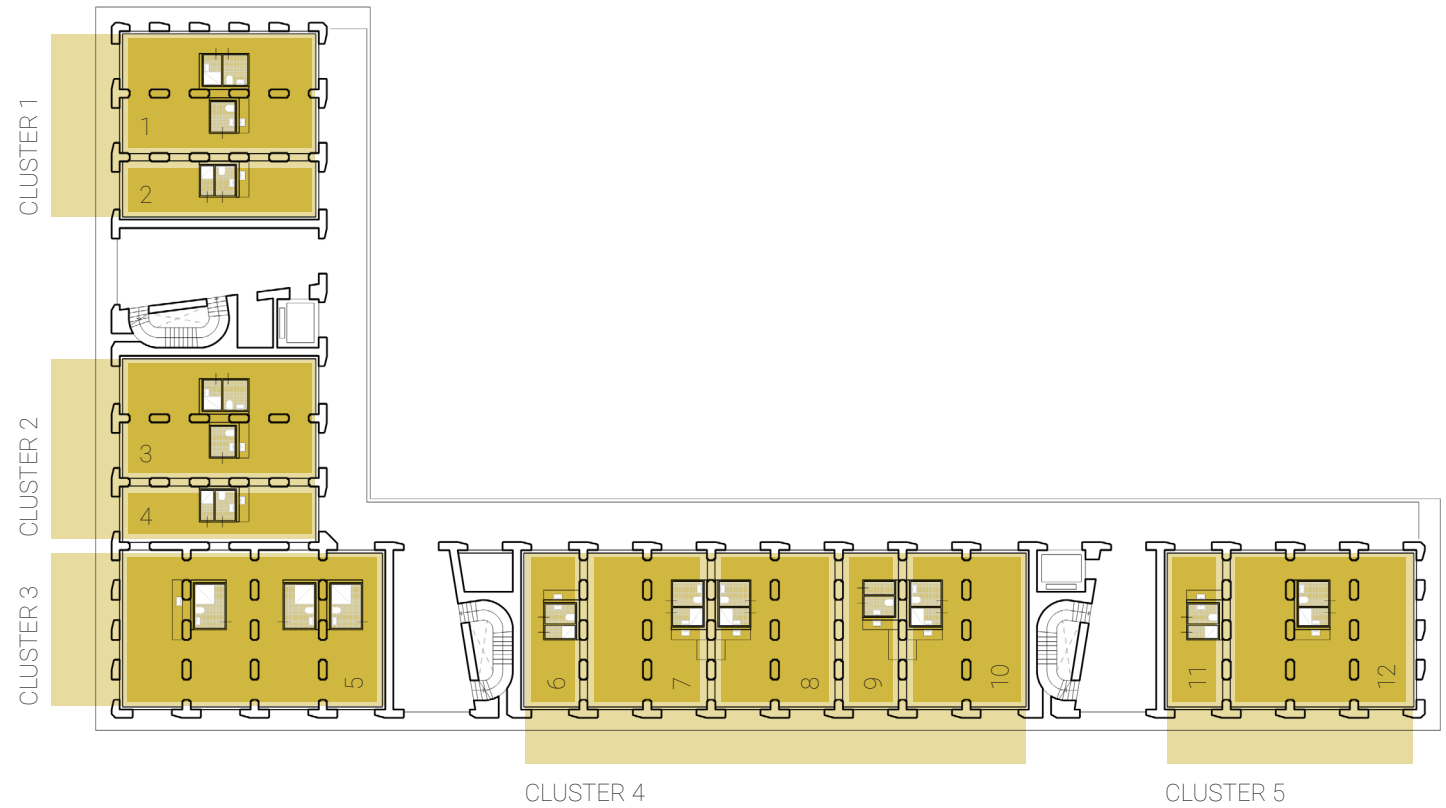

How does it work in a building?

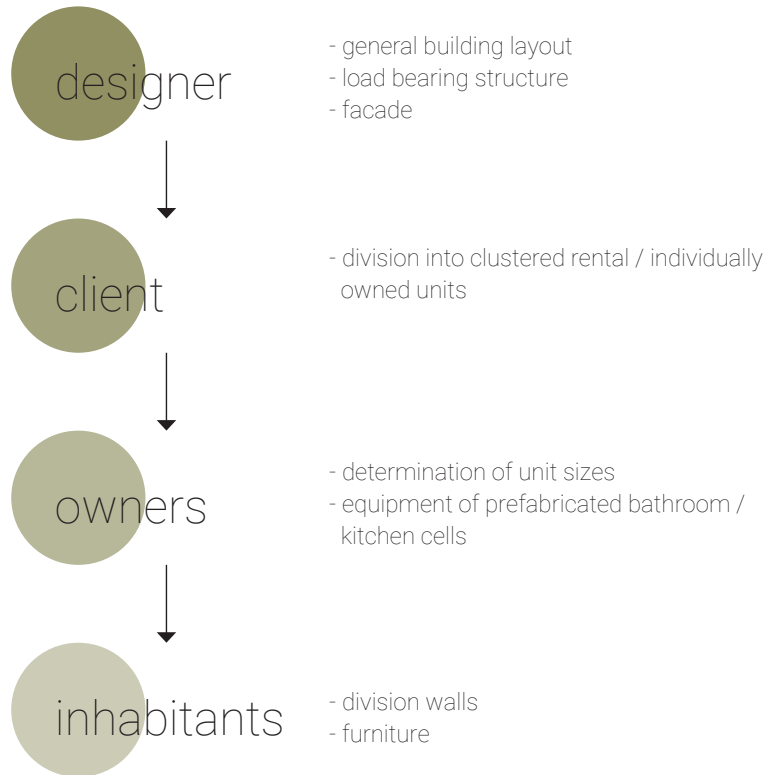

Problem Statement

Research

Implementation

Urban Scale

Building Scale

Recap

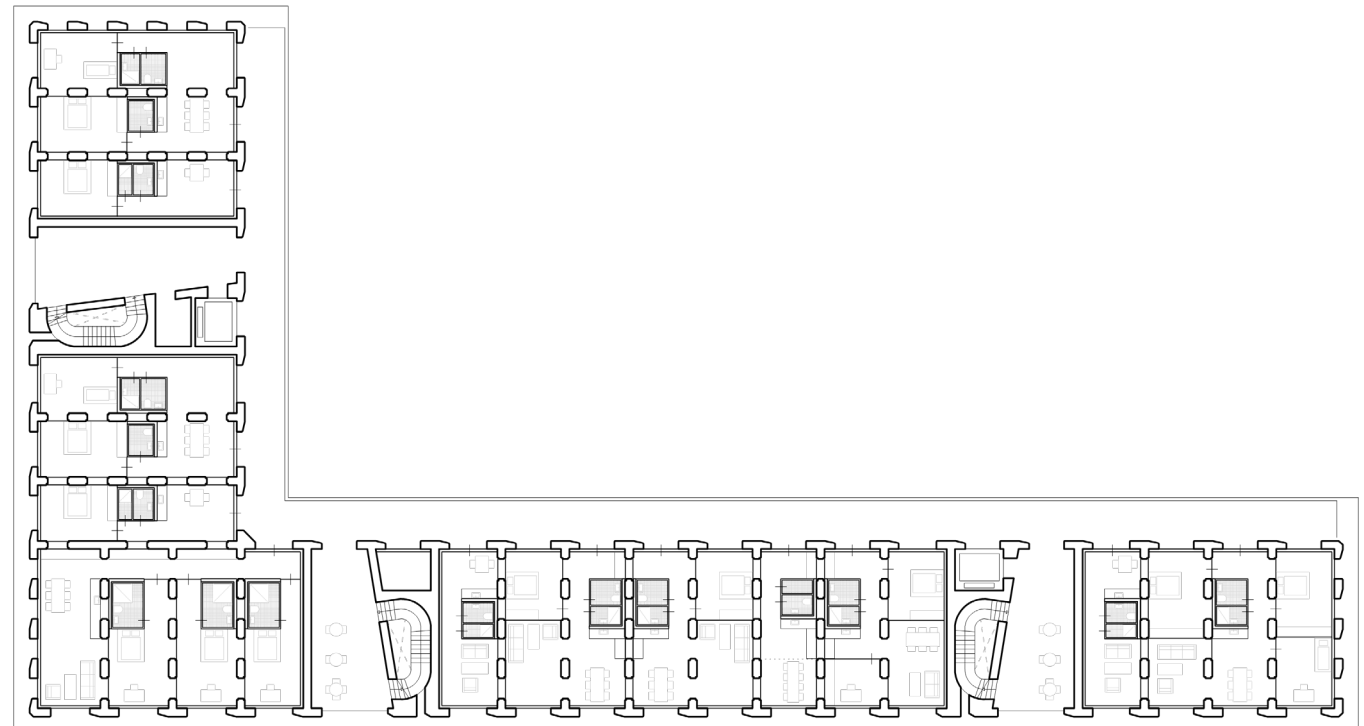

Interior Scheme

Problem Statement

Research

Implementation

Urban Scale

Building Scale

Recap

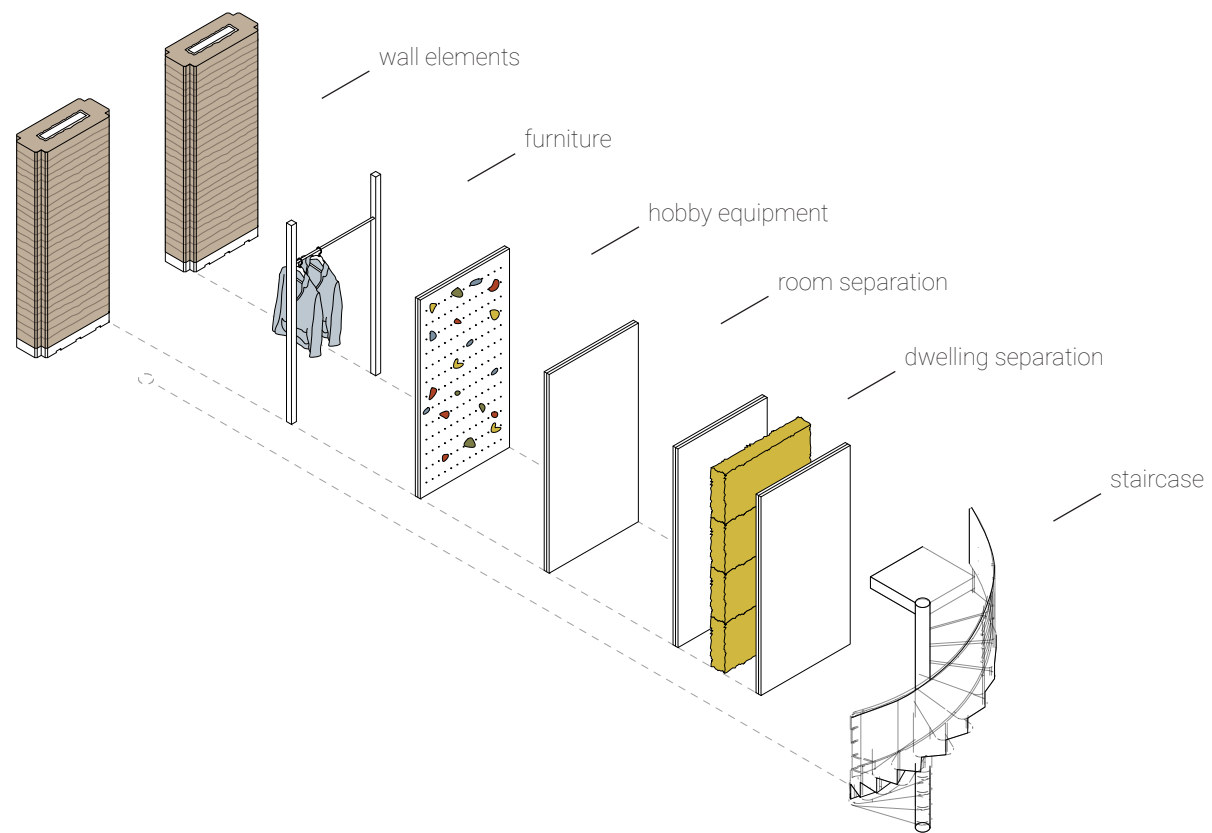

Interior Perspective



Problem Statement

Research

Implementation

Urban Scale

Building Scale

Recap



Interior Perspective



Problem Statement

Research

Implementation

Urban Scale

Building Scale

Recap



Ground floor



- Problem Statement
- Research
- Implementation
- Urban Scale
- Building Scale**
- Recap

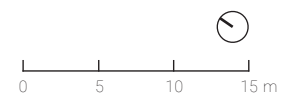

Ground floor

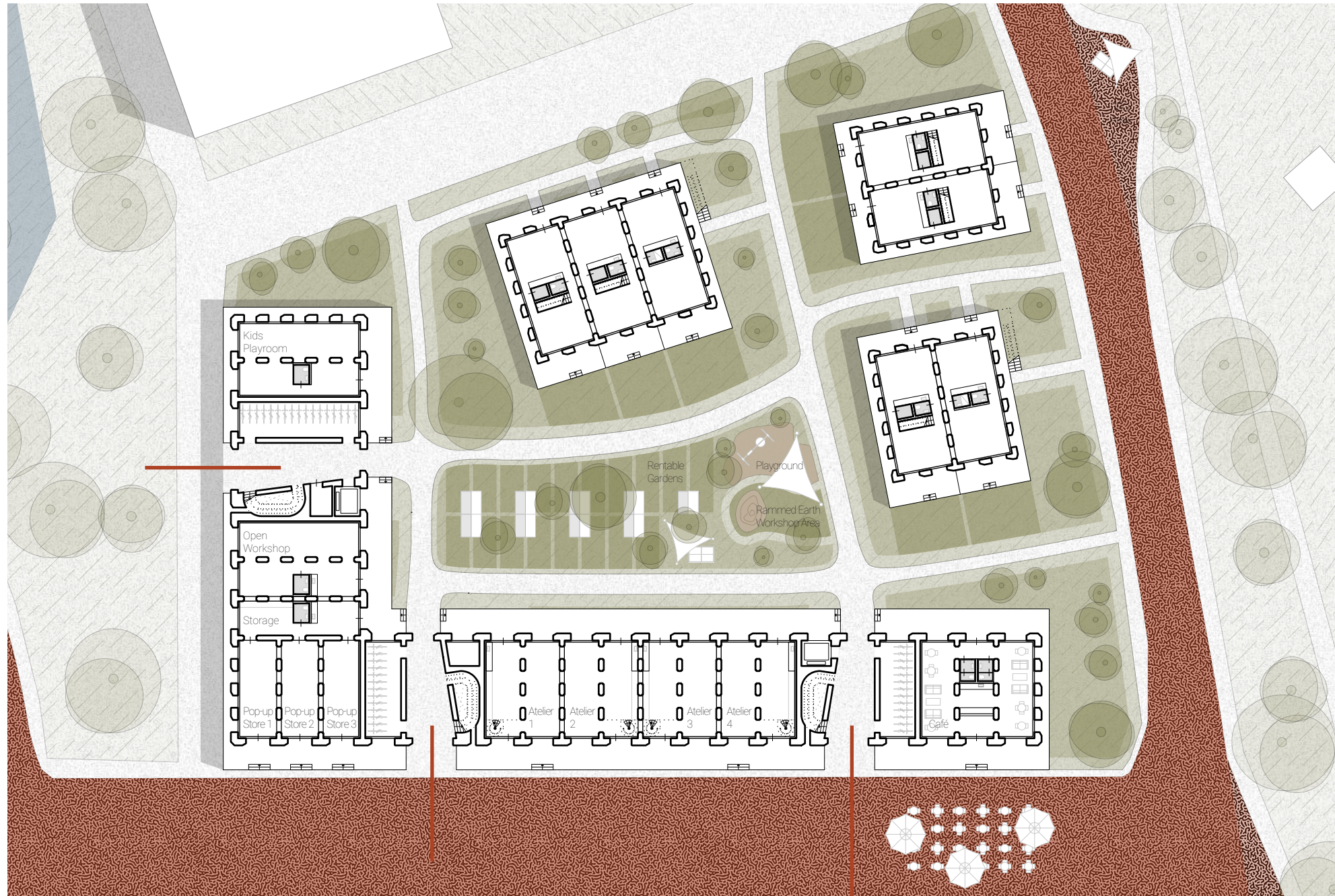

- Problem Statement
- Research
- Implementation
- Urban Scale
- Building Scale**
- Recap



entrance areas

Ground floor



playroom

workshop

pop-up stores

artist in residence

cafe

- Problem Statement
- Research
- Implementation
- Urban Scale
- Building Scale**
- Recap

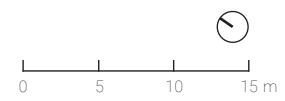

Ground floor

rentable
gardens

workshop
area

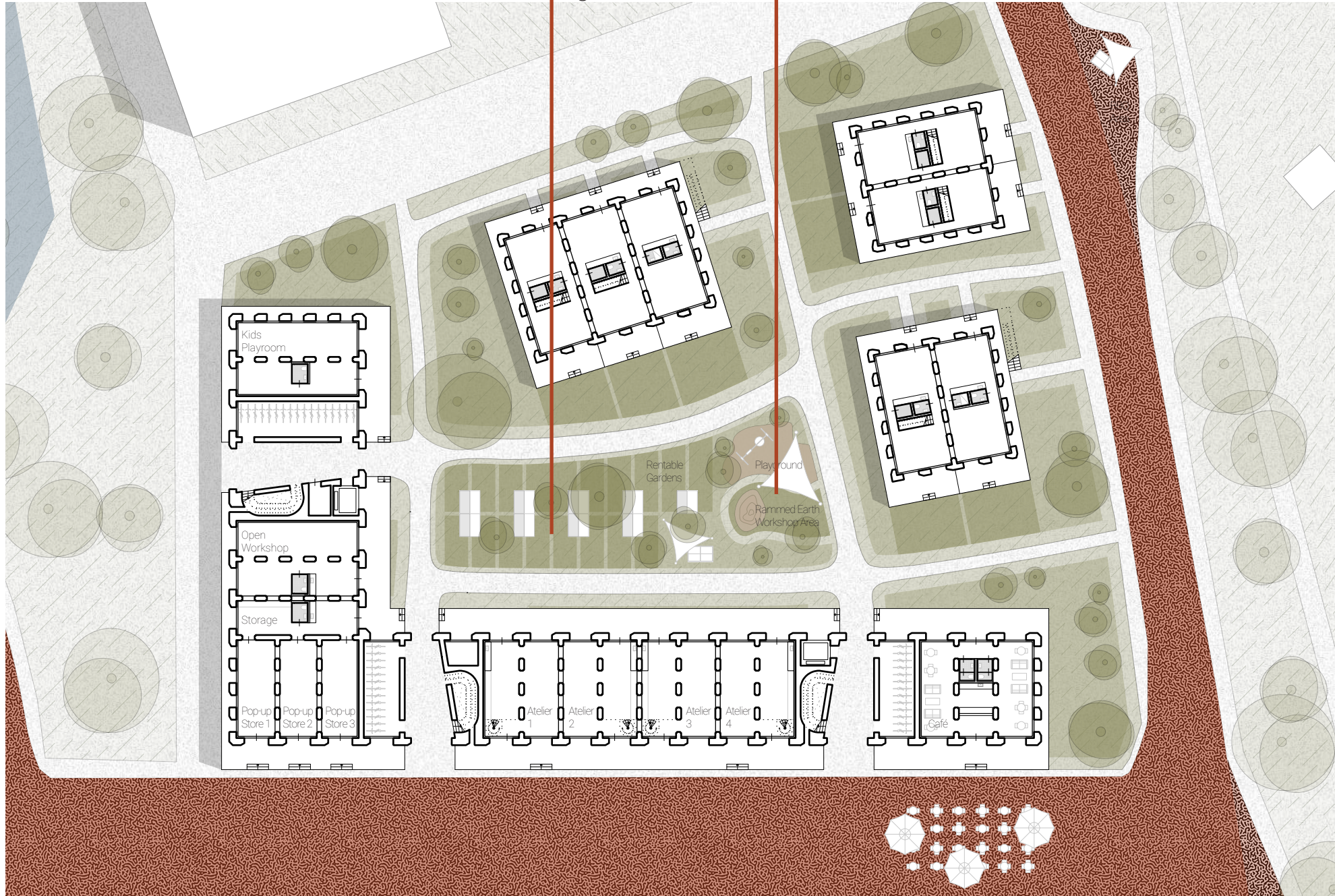

Problem
Statement

Research

Implementation

Urban Scale

Building Scale



Recap

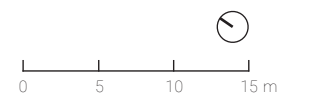

First floor

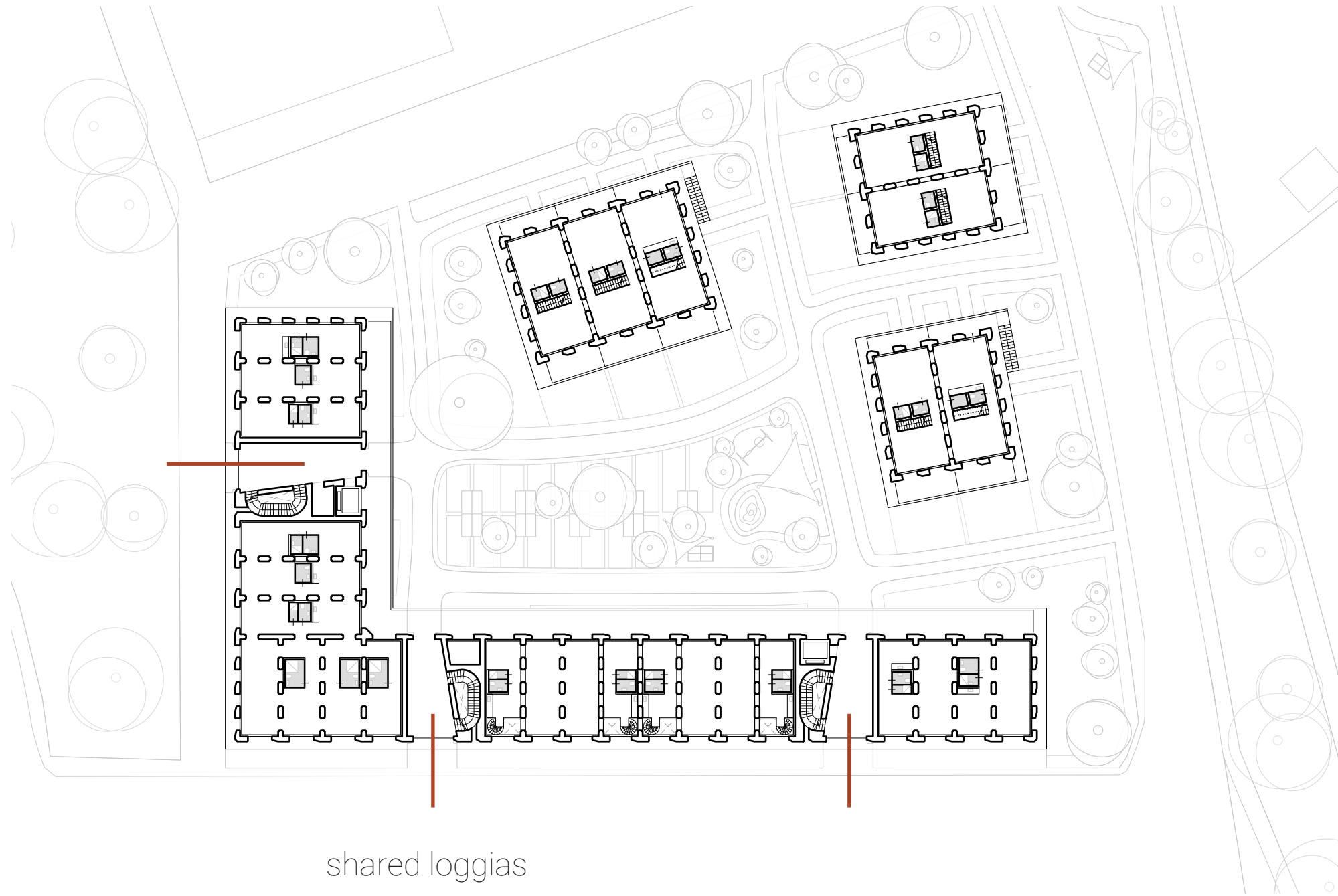

- Problem Statement
- Research
- Implementation
- Urban Scale
- Building Scale**
- Recap

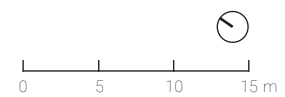

Second floor

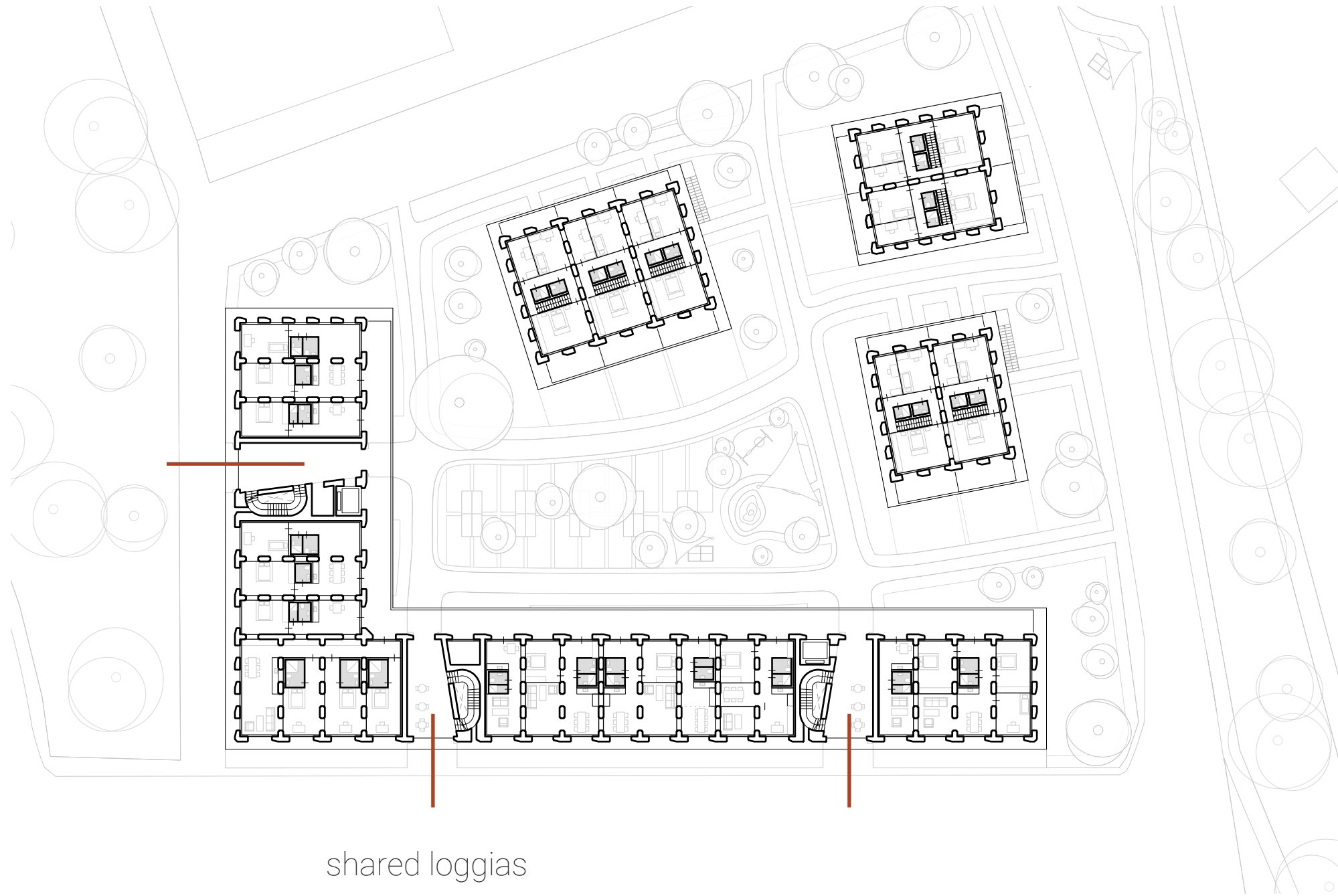

shared loggias

- Problem Statement
- Research
- Implementation
- Urban Scale
- Building Scale**
- Recap

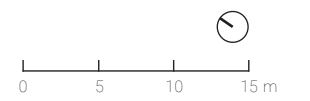

Third + Fourth floor

Problem Statement

Research

Implementation

Urban Scale

Building Scale

Recap

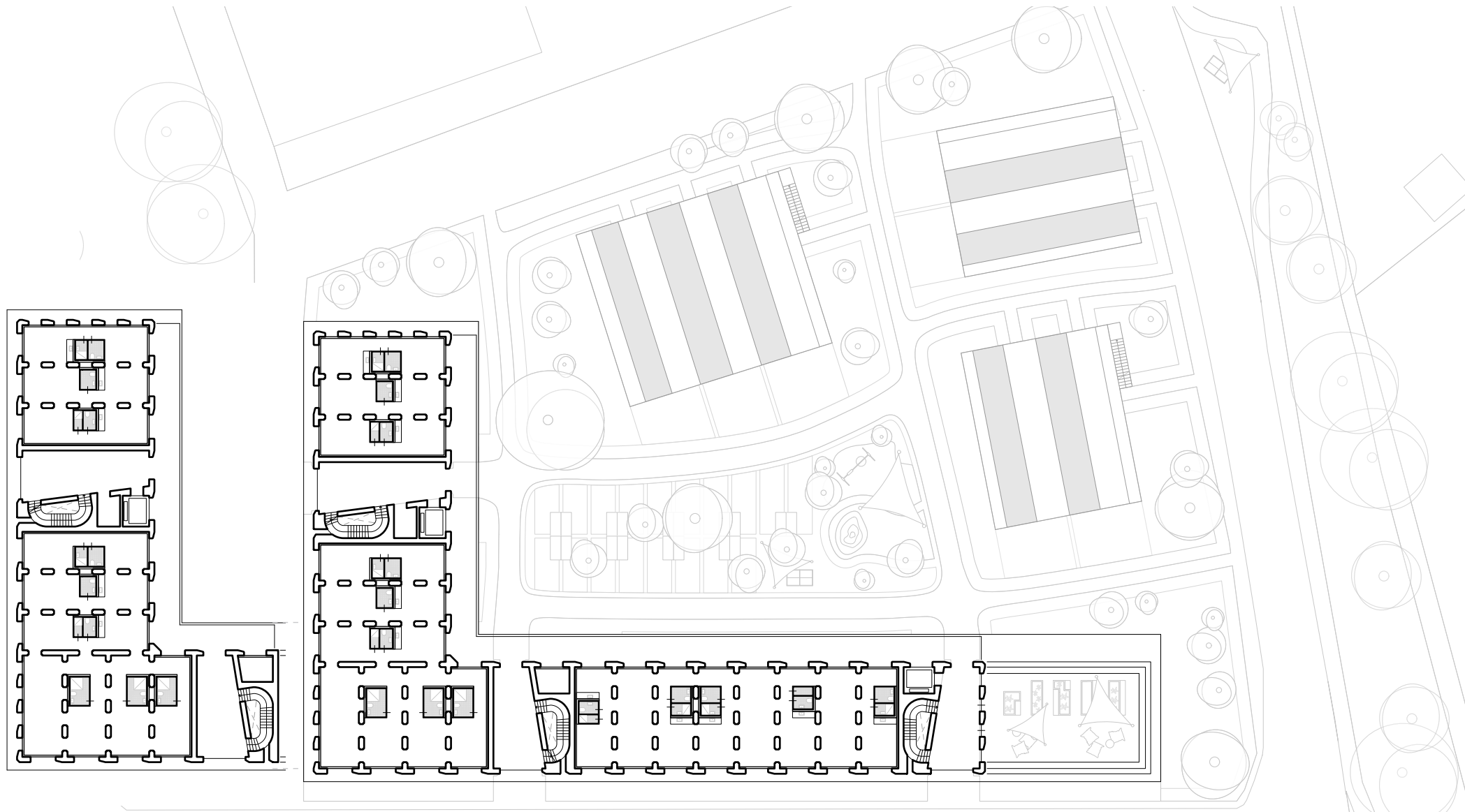

roof terrace

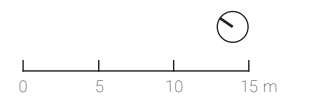

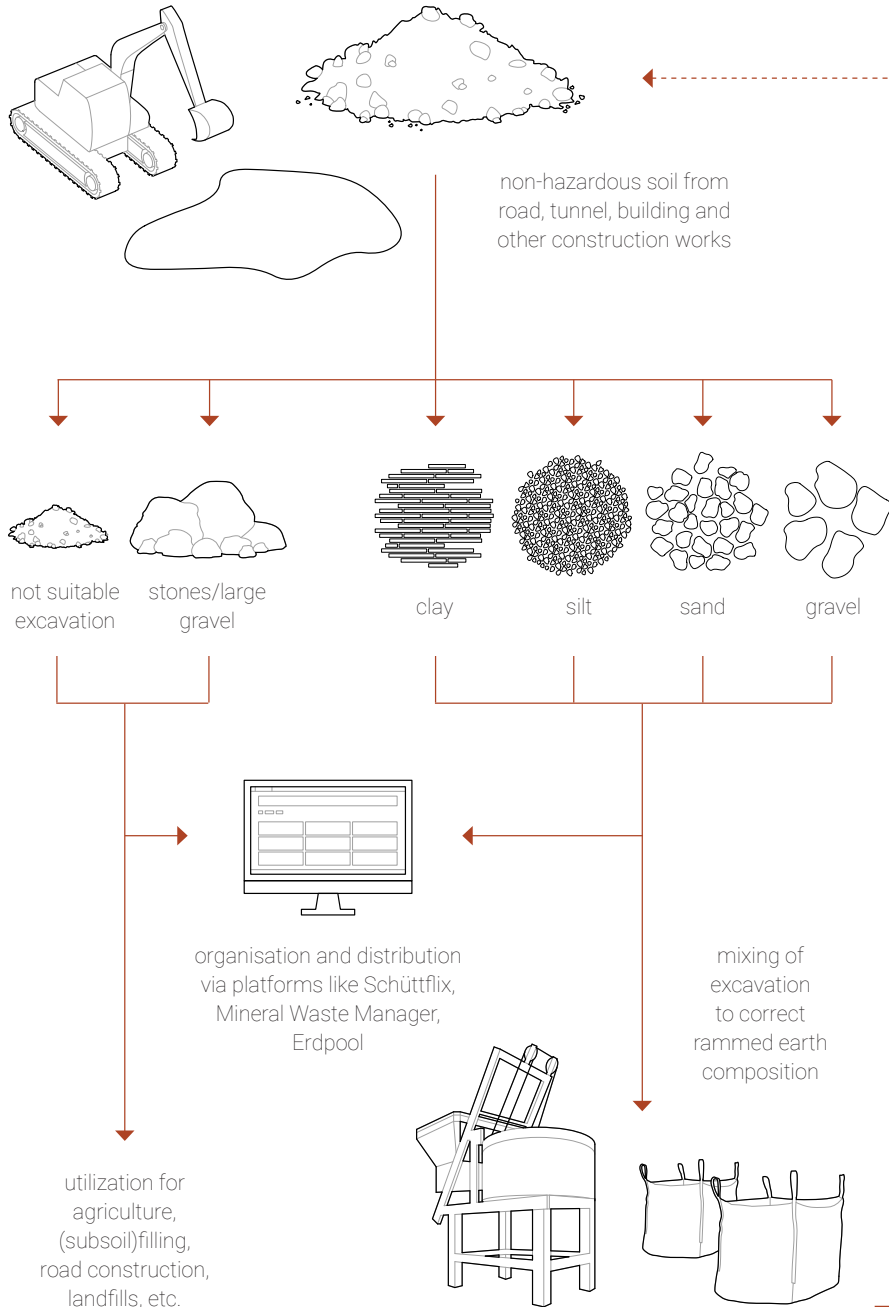

circular use of the material

applications within the prefabricated housing system

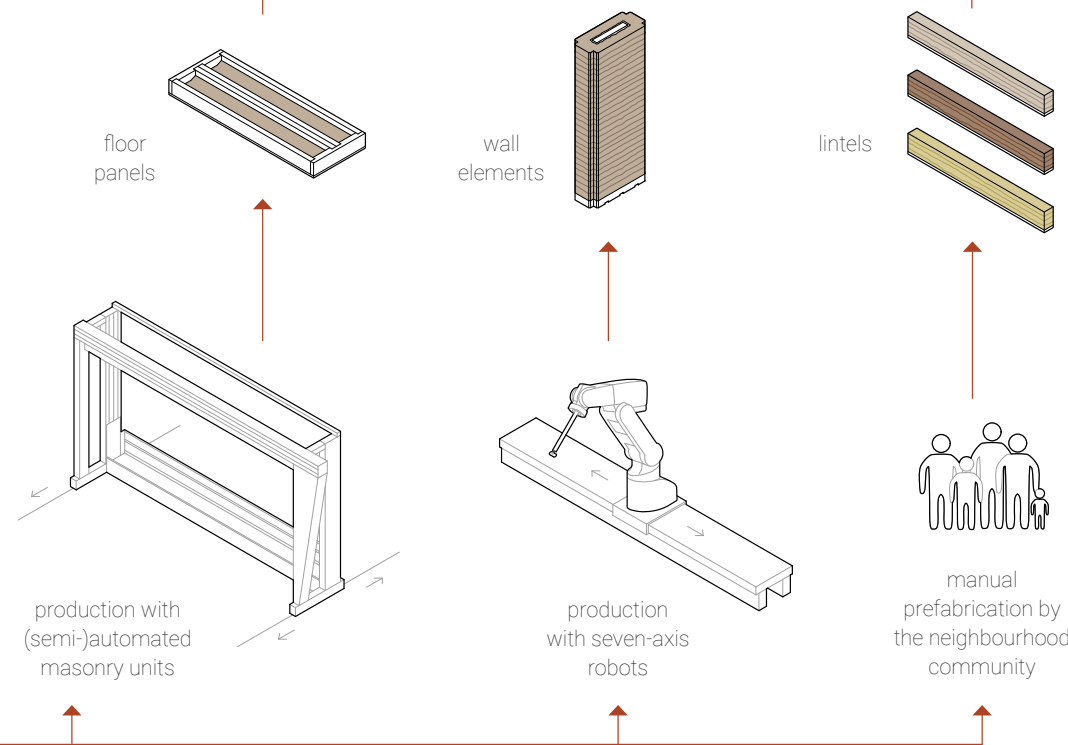
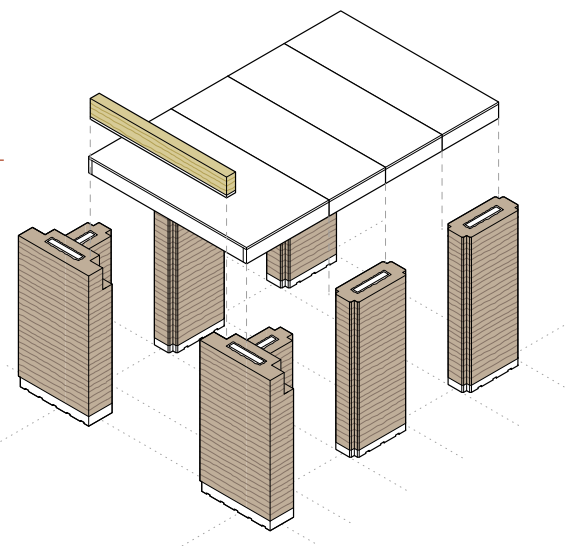

- Problem Statement
- Research
- Implementation
- Urban Scale
- Building Scale**
- Recap



Problem
Statement

Research

Implementation

Urban Scale

Building Scale

Recap

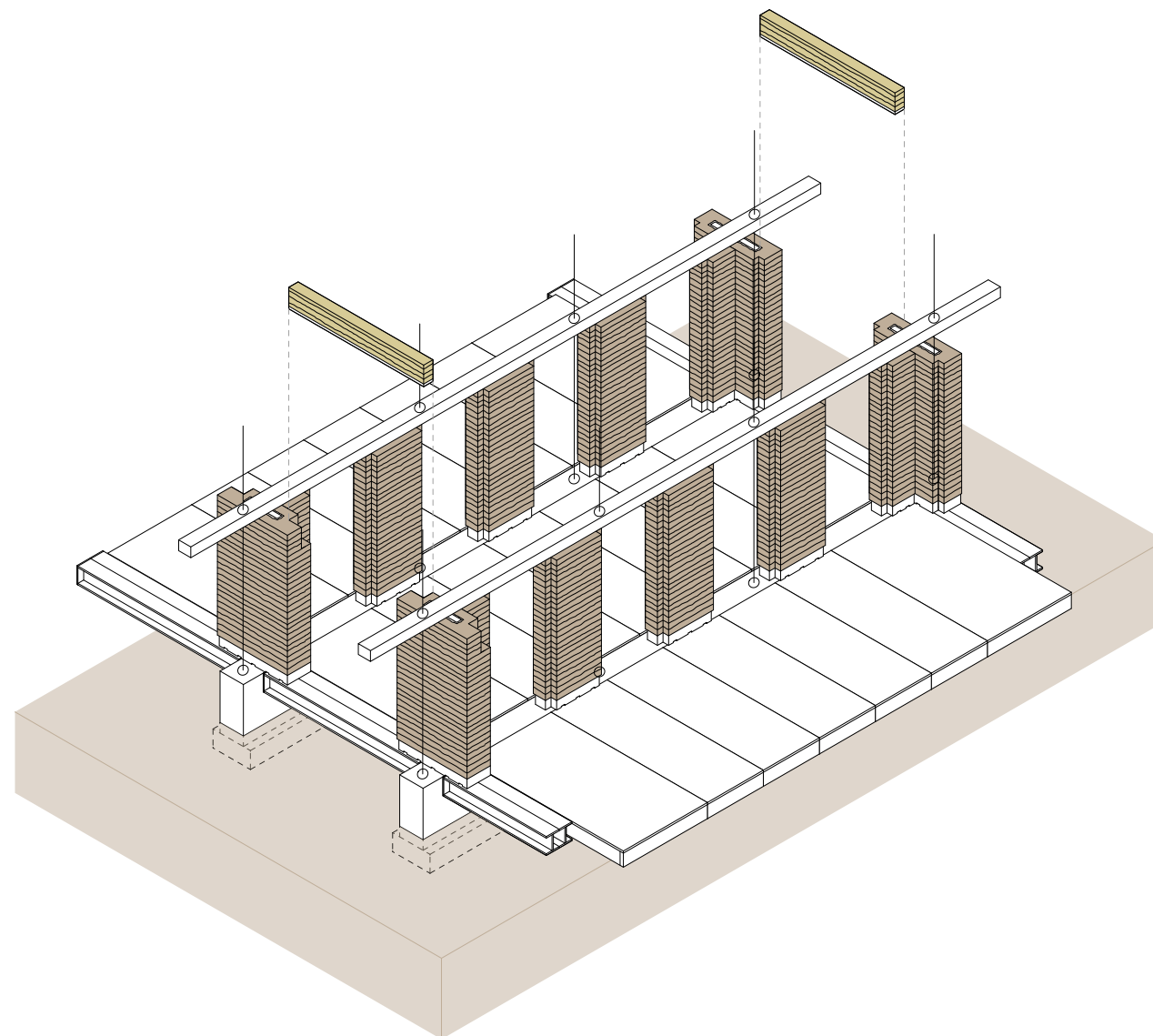

Problem
Statement

Research

Implementation

Urban Scale

Building Scale

Recap

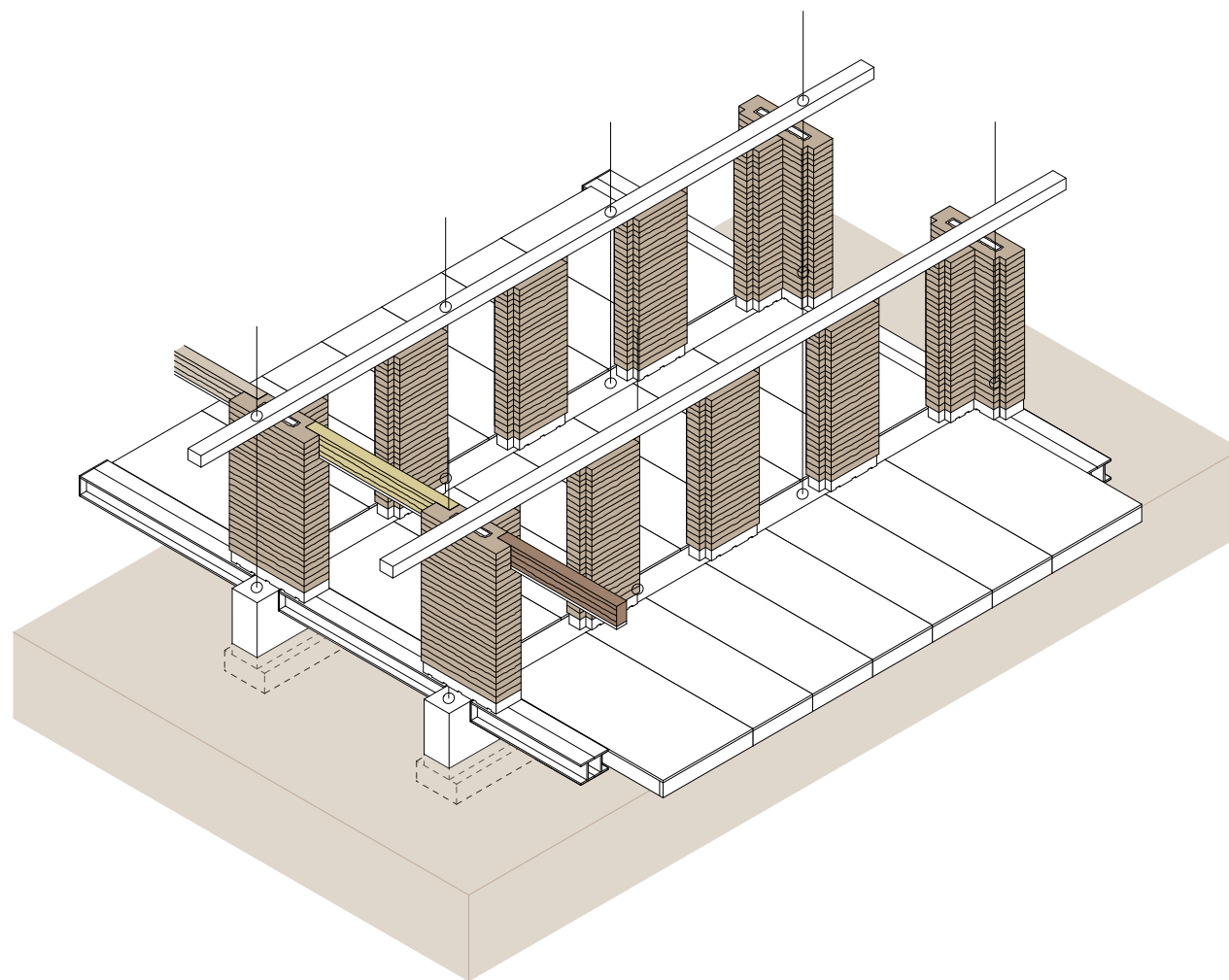

Exterior perspective



Problem Statement

Research

Implementation

Urban Scale

Building Scale

Recap



Elevations

- Problem Statement
- Research
- Implementation
- Urban Scale
- Building Scale**
- Recap



West Elevation 1:500

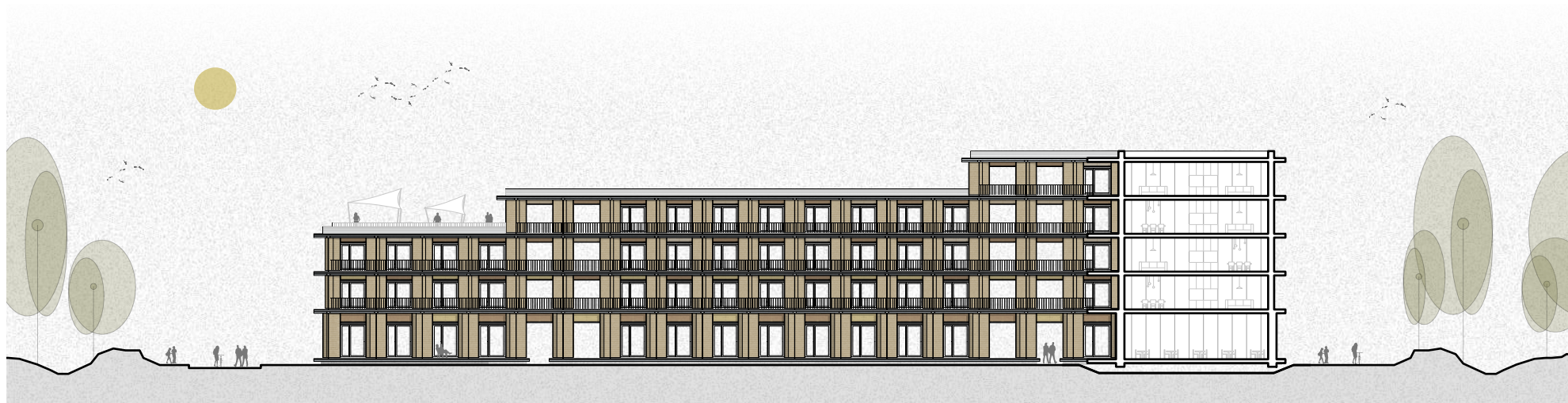

East Elevation 1:500



Elevations

- Problem Statement
- Research
- Implementation
- Urban Scale
- Building Scale**
- Recap



North Elevation 1:500



South Elevation 1:500



Facade Section

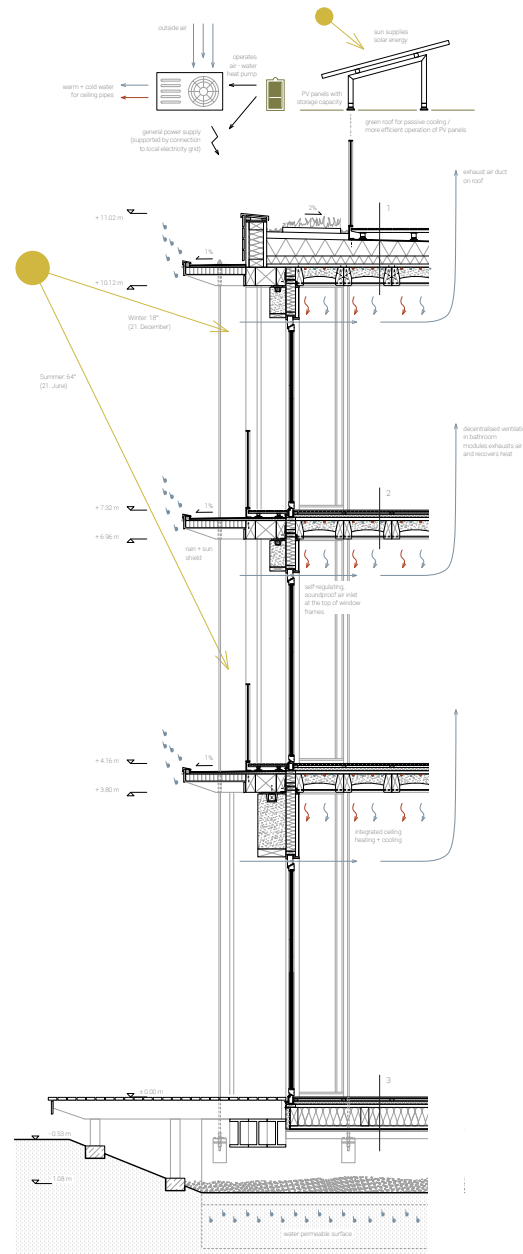
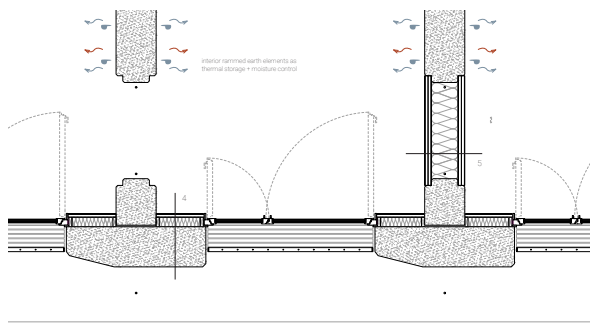

Problem Statement

Research

Implementation

Urban Scale

Building Scale

Recap



Energy Generation

Problem Statement

Research

Implementation

Urban Scale

Building Scale

Recap

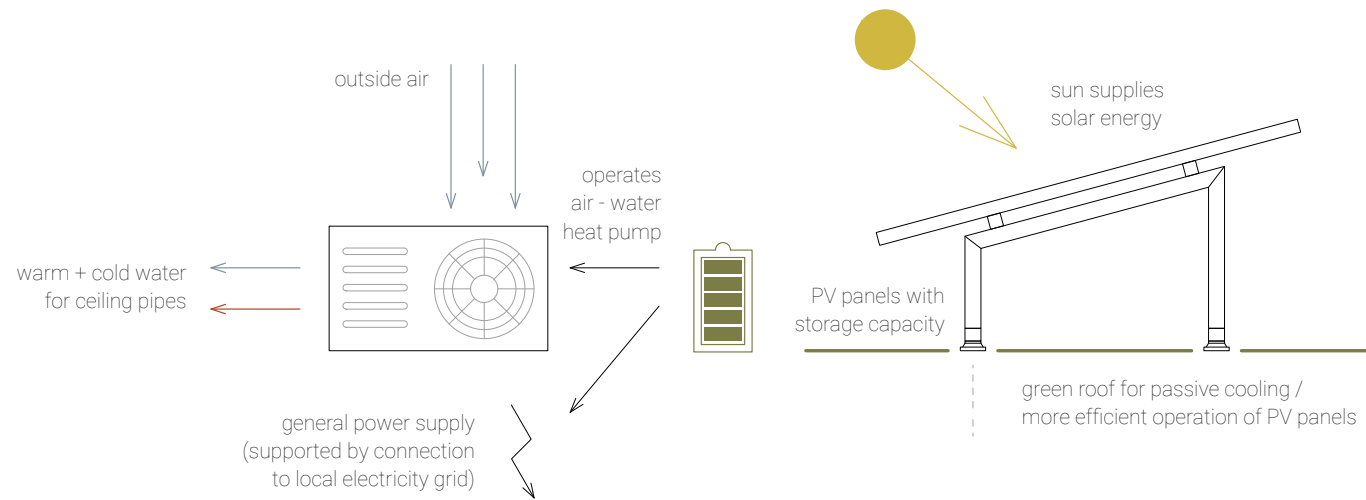

Climate Control

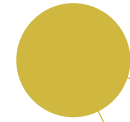

+ 11.02 m

+ 10.12 m

Winter: 18°
(21. December)

Summer: 64°
(21. June)

+ 7.32 m

+ 6.96 m

rain + sun
shield

self-regulating,
soundproof air inlet
at the top of window
frames

exhaust air duct
on roof

decentralised ventilation
in bathroom
modules exhausts air
and recovers heat

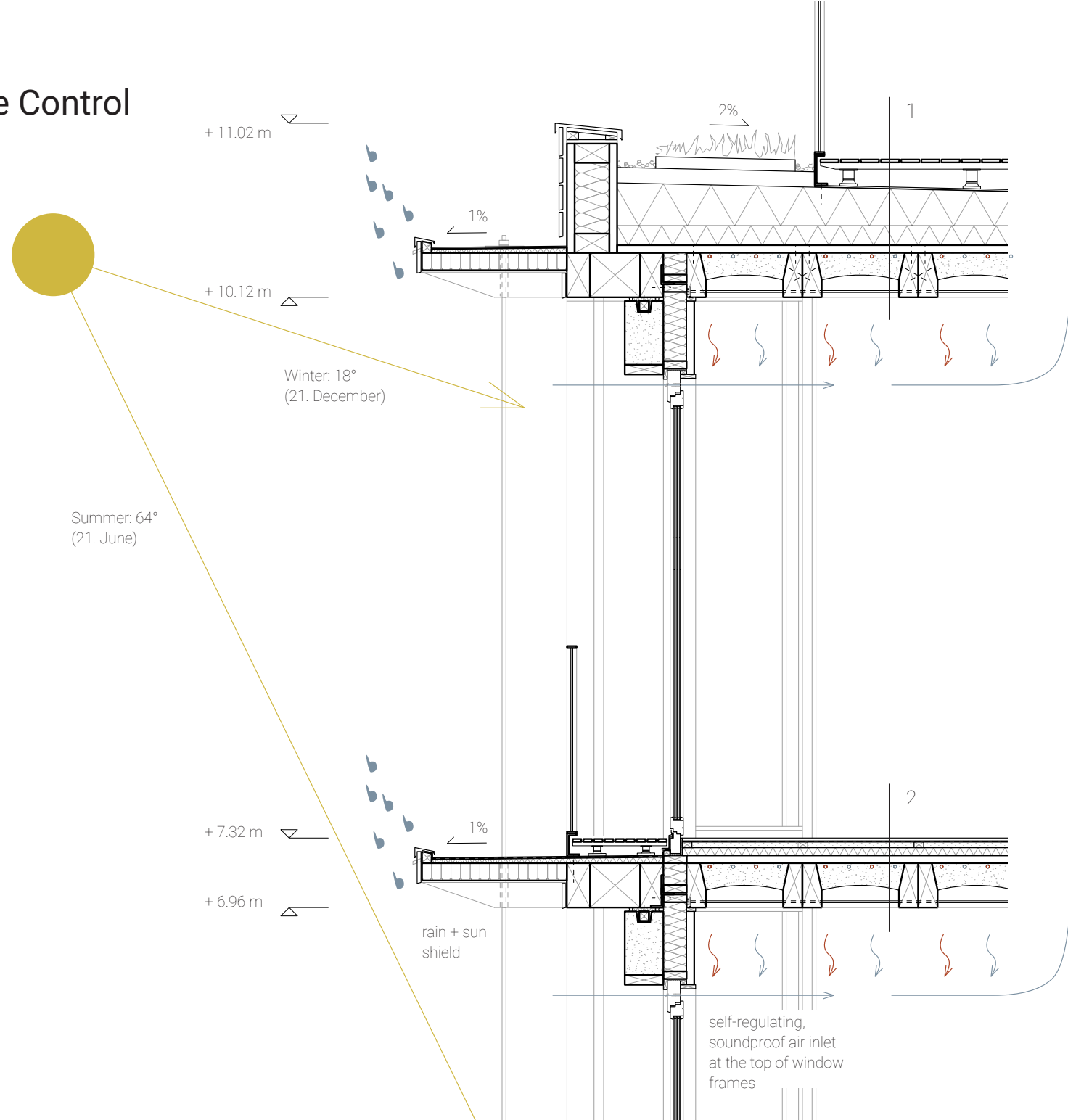

Problem
Statement

Research

Implementation

Urban Scale

Building Scale

Recap



Climate Control

Problem Statement

Research

Implementation

Urban Scale

Building Scale



Recap

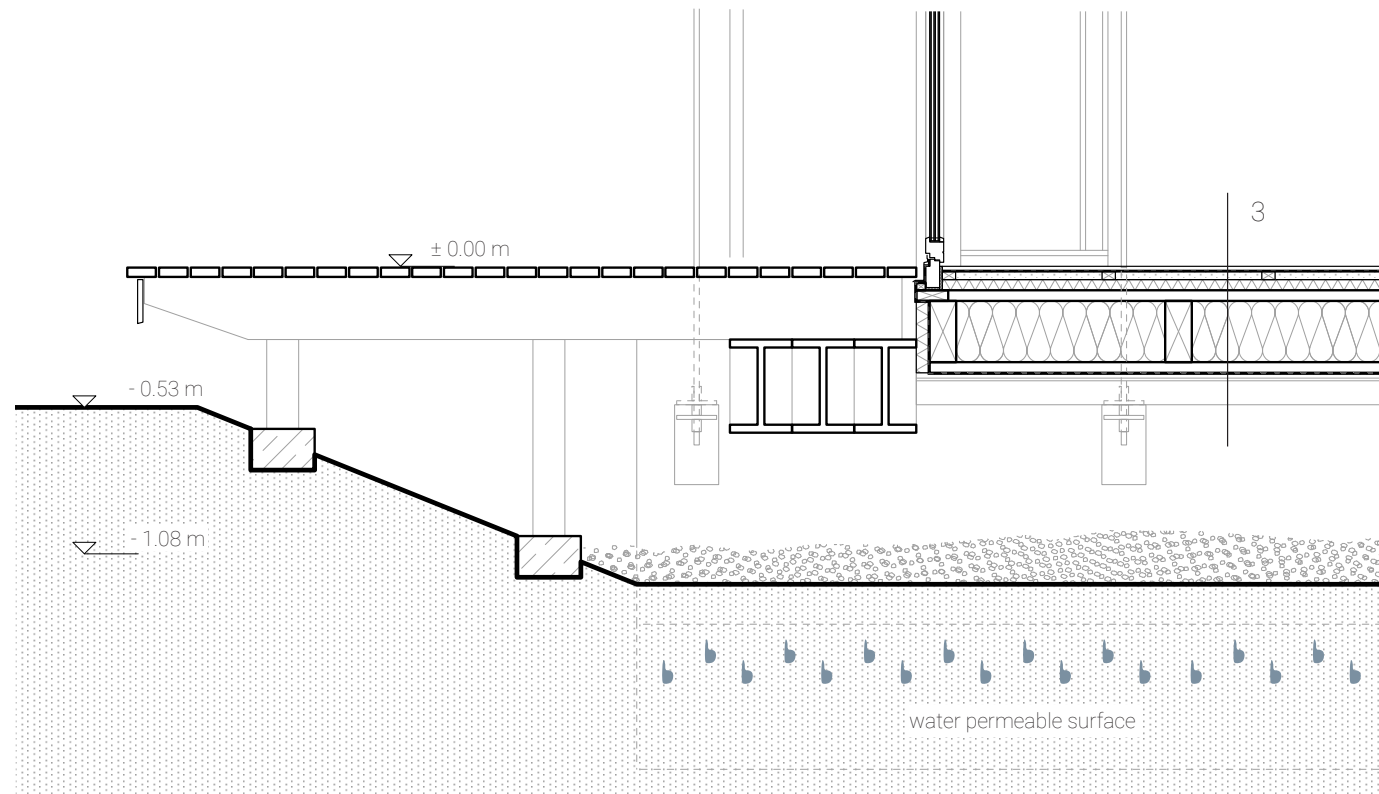

Climate Control

Problem Statement

Research

Implementation

Urban Scale

Building Scale



Recap

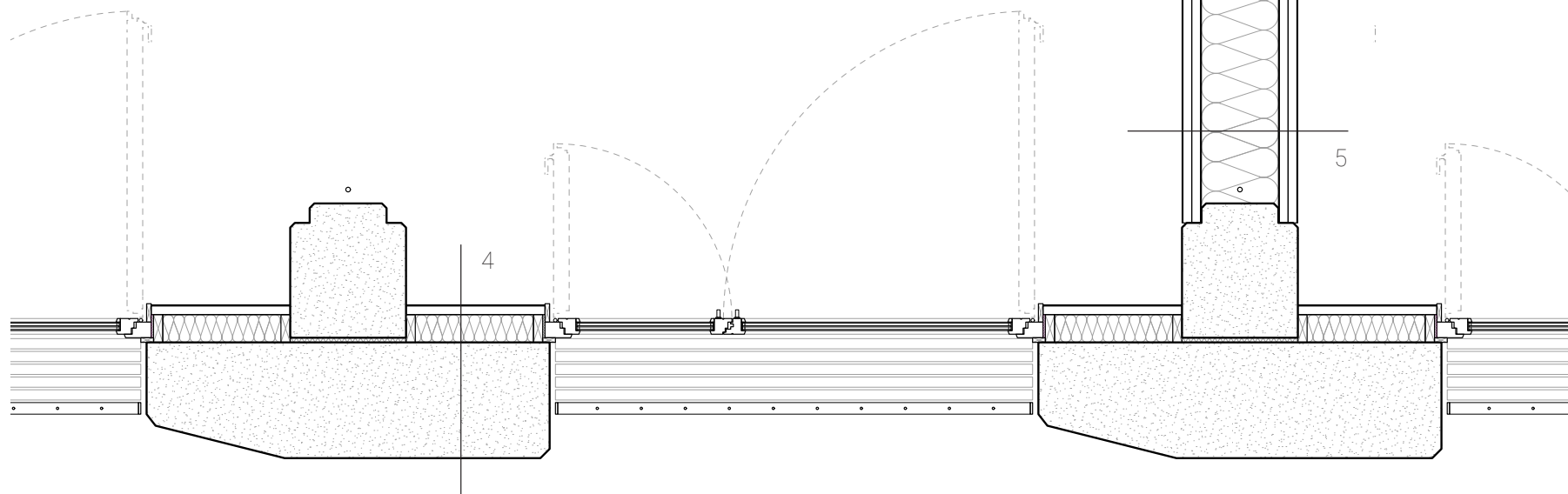
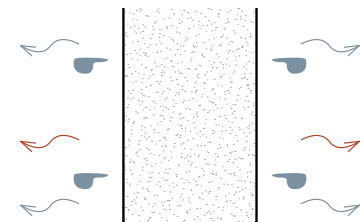
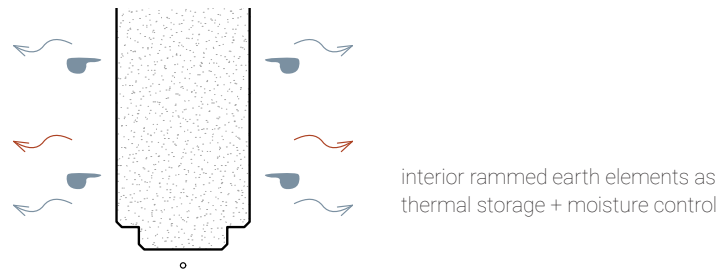

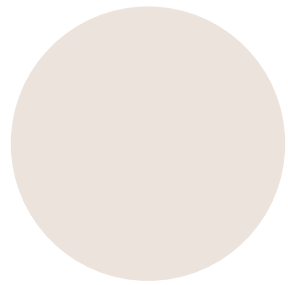

Recap

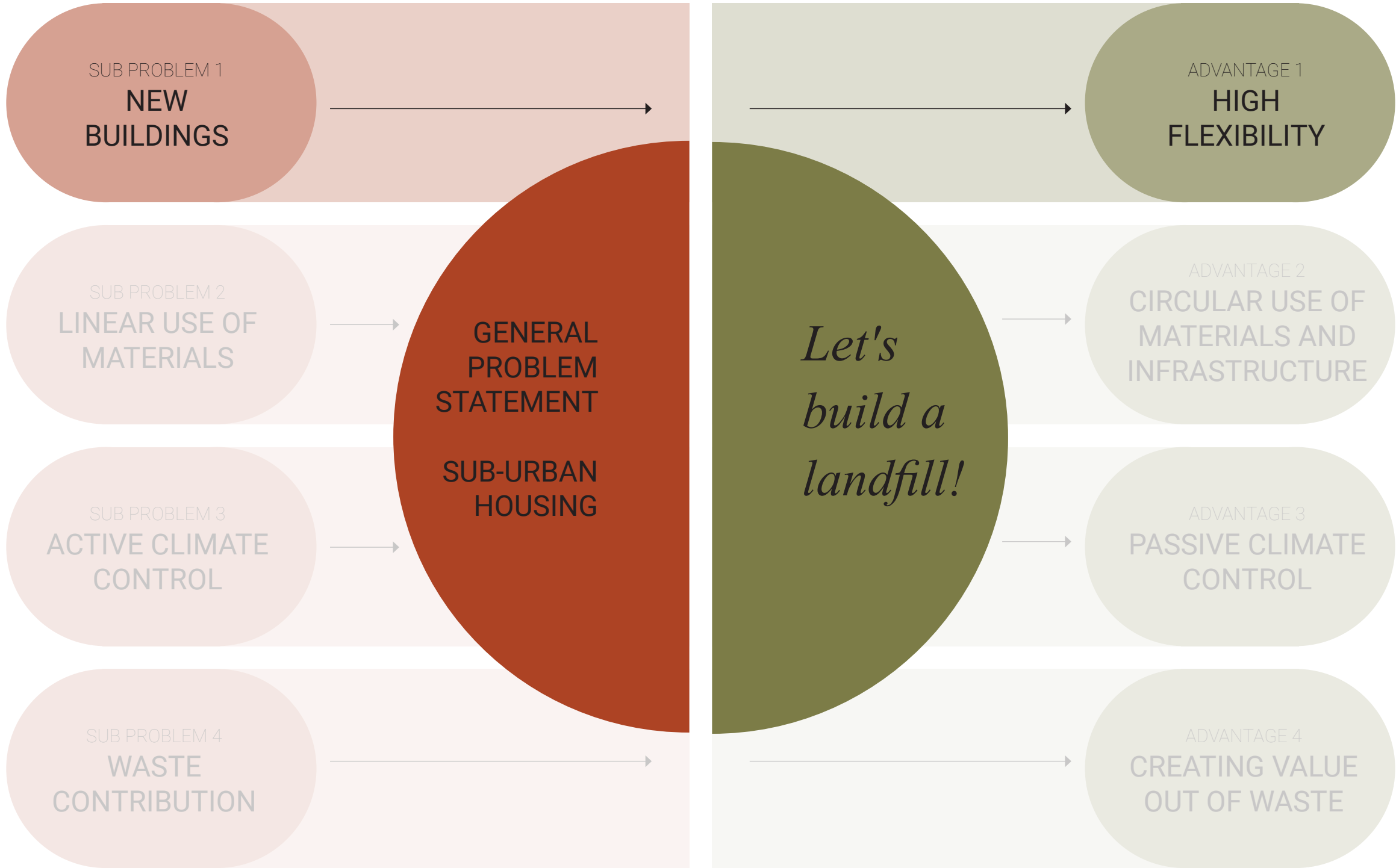

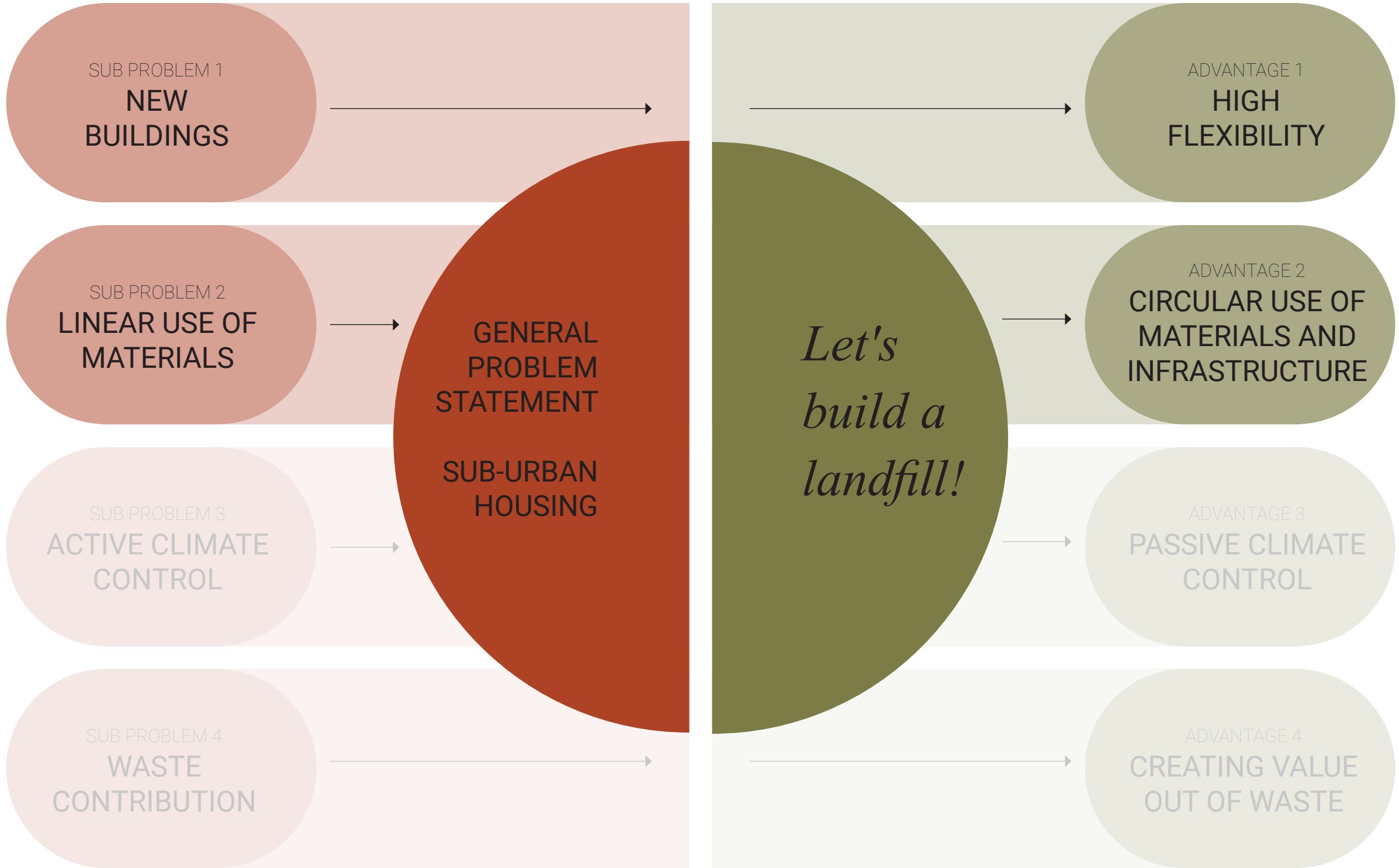

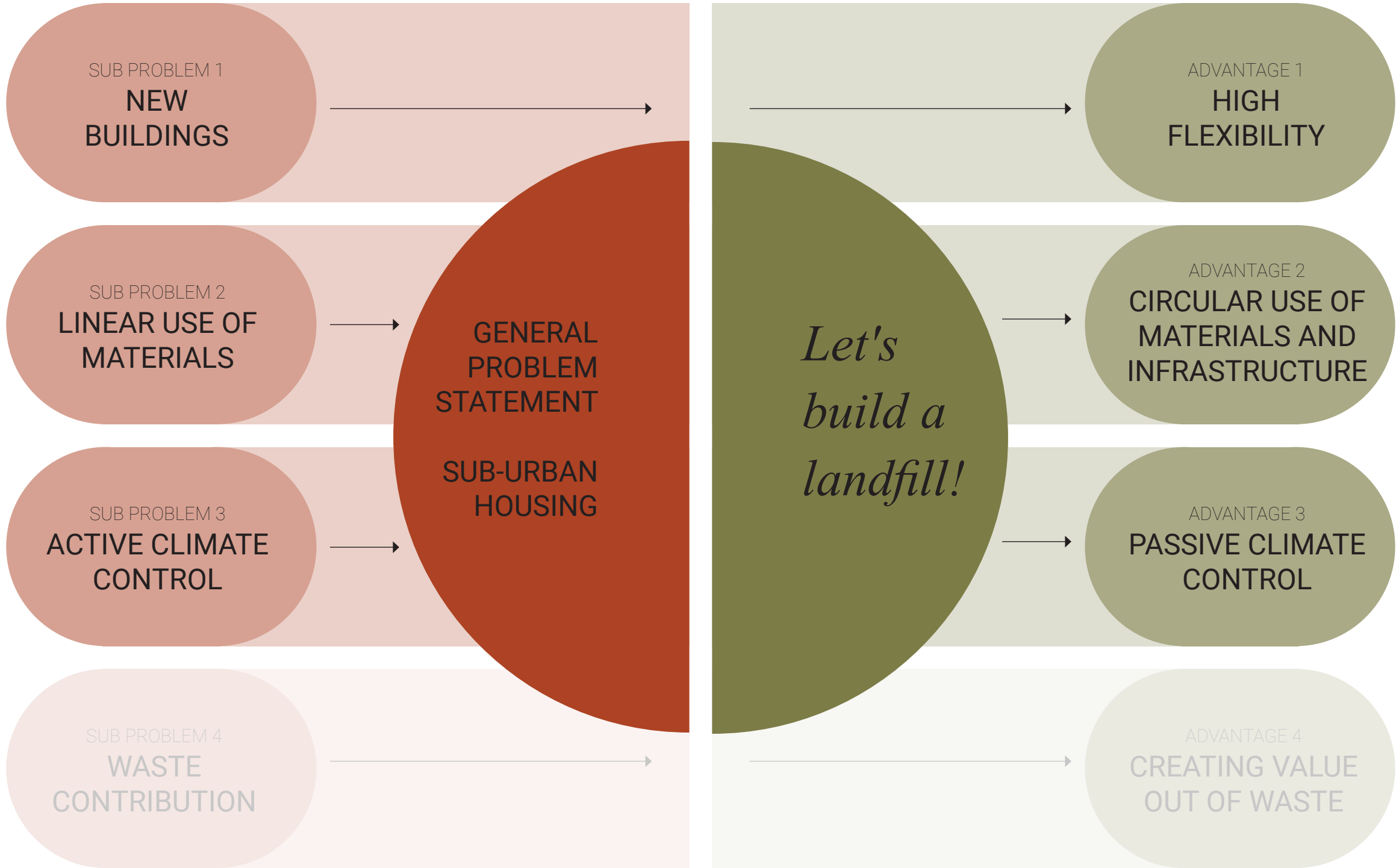

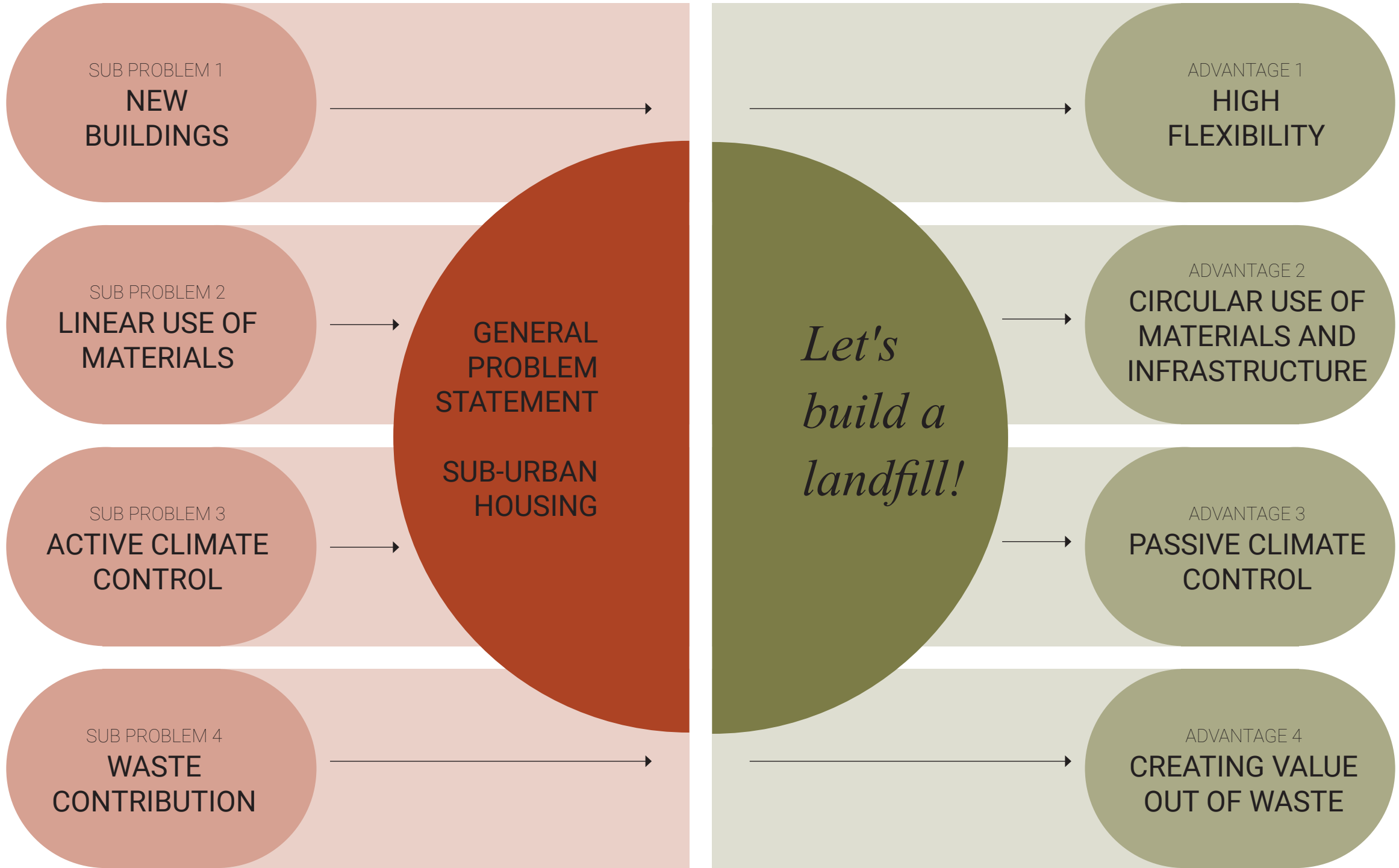

Material Use (in one unit over three stories)



1

connected neighbourhood

1 connected neighbourhood

1 400 connectable units

1 connected neighbourhood

1 400 connectable units

40950 t of purposefully banked soil excavations

1 connected neighbourhood

1 400 connectable units

40950 t of purposefully banked soil excavations

88% less CO2 emissions compared to concrete

Let's build a lot of landfills!

