

# Spatial Adaptive Policy Pathways

FOR RAINWATER RESILIENT SPATIAL REDESIGN FOR URBAN AREAS

BY CHARLIE JURJUS

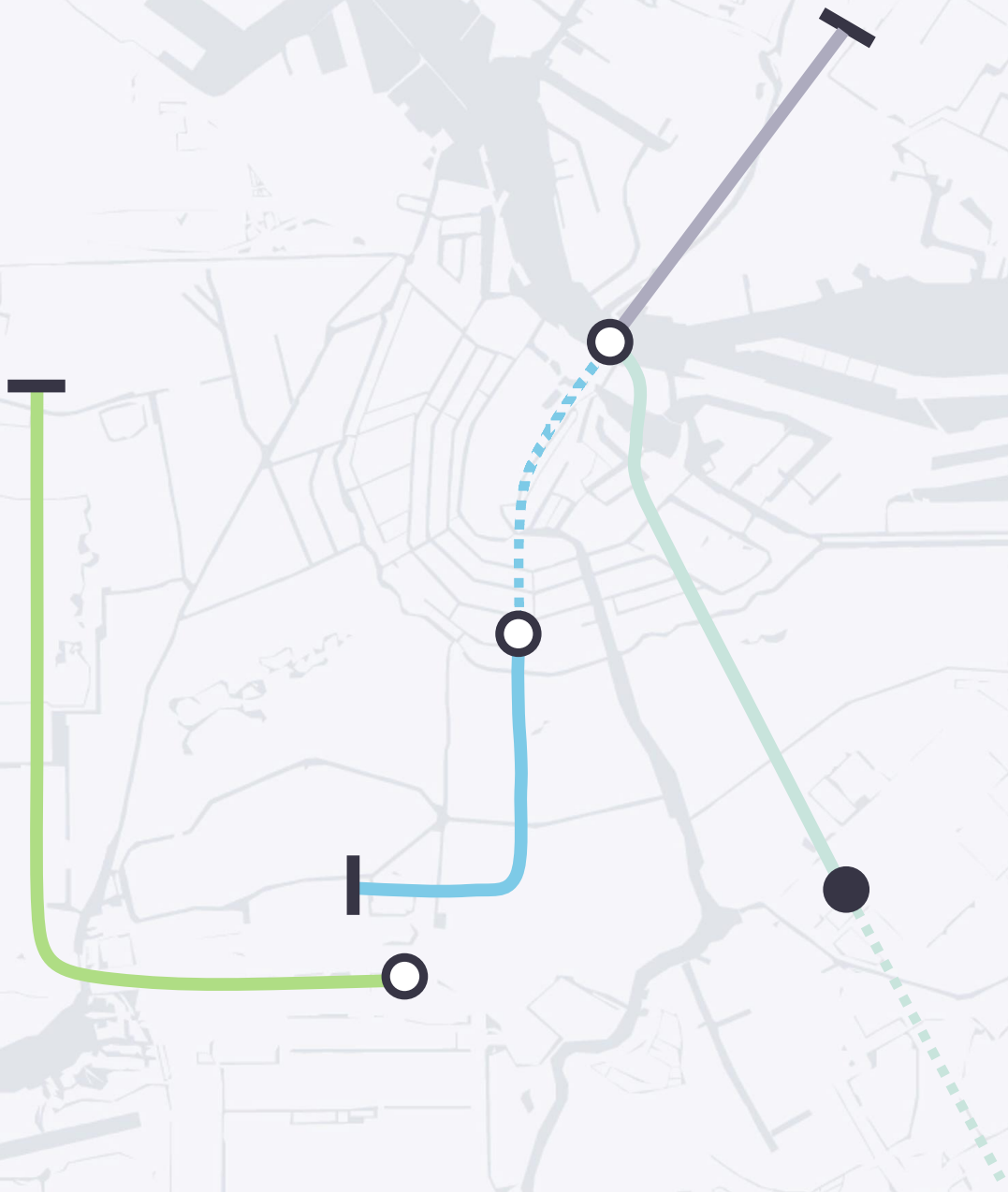



# Spatial Adaptive Policy Pathways

## FOR RAINWATER RESILIENT SPATIAL REDESIGN FOR URBAN AREAS

by C.L. Jurjus

in partial fulfilment of the requirements for the degree of Master of Science in Civil Engineering  
at the Delft University of Technology,  
to be defended publicly on Friday the 4<sup>th</sup> of August 2023 at 1:00 PM.

Graduation committee:

dr. ir. M.M. Rutten (chair)  
Water Resources – Faculty of Civil Engineering and Geosciences – TU Delft

dr. ir. V.E. Balz (supervisor)  
Urbanism – Faculty of Architecture and the Built Environment – TU Delft

prof. dr. ir. J.P. van der Hoek (supervisor)  
Sanitary Engineering – Faculty of Civil Engineering and Geosciences – TU Delft

ir. Daniel Goedbloed (external supervisor)  
Stichting Waternet

An electronic version of this thesis is available at <http://repository.tudelft.nl>

July 2023





# Acknowledgements

Starting this research, I had envisioned graduating to be a daunting and challenging mountain that we all had to climb. Seeing my peers giving it their best and succeeding, I approached it with both fear and excitement. When I arrived at the start of the thesis with a great deal of interest in urban climate adaptation and spatial design. My love for the topic would turn out to be my greatest motivator. Conveniently so, as the road ahead is a dynamic and diverse process that, at times, leaves you without energy to motivate yourself. It is a struggle that I found out to be prevalent amongst my peers but is not discussed as much as I think it should. A fundamentally valuable lesson that I have learned in this process is that opening up about things that you find deeply difficult and perhaps bring you shame, is very appreciated, reciprocal and, I believe, highly necessary in this environment.

Delft has been my home for many years, and I look back with fulfilment. I have tried to enjoy it as much as I could and would not change a thing. I am happy to have found a passion in urban climate adaptation and my time at Amsterdam Rainproof was the most fun and inspiring highlight of my educational career. I would like to thank my colleagues for their mentorship and infectious ambition during the eighteen months I spent with them.

To my supervisors for this thesis, I would like to express my deep gratitude for your help, your understanding and your patience. You have allowed me to learn more than I could have imagined.

Above all, I would like to express my gratitude to my family, my friends and Bas, for the endless love and support. It truly is the most important thing.



# Abstract

In this research, the use of spatially applied adaptive pathways for rainwater resilient redesign of urban areas is investigated. It is explored how adaptive pathways can contribute to the integration of the climate stress of pluvial flooding in the planning process for the redesign of existing urban areas. This is done by developing adaptive pathways for the rainwater resilient design for a case-study in Amsterdam and evaluating their possible contribution to the planning process for redesign in general and specifically in Amsterdam.

The planning process for spatial redesign in Amsterdam was analysed to see to what extent pluvial flooding is integrated as a design principle in the decision-making process for spatial adaptations in the public space, i.e., changes to the spatial design of infrastructures, or renewal and maintenance. It was found that considering rainwater resilience as a criterium for spatial redesign is not standardized nor obligatory in the planning- and decision-making process for the redesign of the urban public space in Amsterdam. This is problematic, as the results for the case-study show that because of the long lifespan of infrastructural objects and considering the fast-growing need for implementation of rainwater storage capacity in the face of the 2050 objective, the realisation of spatial adaptations that do not contribute to rainwater resilience, is a missed opportunity that can have a significant negative impact on the transition towards a rainwater resilient Amsterdam.

The use of spatially applied adaptive pathways for rainwater resilience was explored by first developing pathways for a redesign for a case study in Amsterdam, the neighbourhood Bosleeuw, following the Dynamic Adaptive Policy Pathways (DAPP) approach. It was found that when considering pluvial flooding as the system stressor, the number of parallel design alternatives that could be included in the map are limited because rainwater resilience is considered at neighbourhood scale. Moreover, the shortage of the rainwater storage capacity in the current situation compared to the set objective for 2050 results in the inability to express the adaptation tipping points in terms of storage capacity and a sell-by date in terms of time. In addition, because of the number and size of the required measures to reach the objective for rainwater resilience in Amsterdam, the need to consider the implementation time in the adaptive pathways arose, to ensure the feasibility of the proposed pathways.

To this end, a set of modifications were made to the set-up of the pathways for a single design alternative, that enhanced the functionality of the pathways to illustrate the feasibility of the implementation of a solution. The results showed that the modified pathway set-up enable the incorporation of the implementation time of measures, the definition of adaptation tipping points and their sell-by dates and reviewing the effect of partially implemented measures combined.

These functionalities are demonstrated by developing pathways for the implementation of the redesign for the case-study under the temporal limit of the renewal strategy in Amsterdam: the strategy to plan all projects in the public space simultaneously and at the moment of planned maintenance or renewal of infrastructure. The results show that the modified set-up of the pathways enable the visualization and comparison of different implementation strategies and allow for the back casting of required actions to attain a set objective, without going into time-consuming or incomprehensible detail. However, the beneficial feature of the DAPP approach to postpone decisions to the future by reviewing parallel solutions and keeping future options open, is eliminated in the modified set-up, that reviews the implementation of a single solution. Similarly, the focus on the duration of implementation time and the consideration of actions in a timeline reduced the feature of the DAPP approach to express moments of decision and action in terms of how far the uncertain development has progressed rather than in time, which is a key attribute of allowing uncertainty in decision-making and design. The modified pathway set-up presented in this research, therefore, should be considered as complementary to the DAPP approach rather than a replacement. Overall, it is concluded that the adaptive pathways can contribute to rainwater resilience planning by providing a guiding spatial and temporal overview of required actions to support decision-making and the monitoring of adequate implementation of spatial adaptations.





# Abbreviations

AP	Adaptive Pathways
ATP	Adaptation tipping points
AGV	Waterschap Amstel, Gooi en Vecht
BZK	Ministerie van Binnenlandse Zaken en Koninkrijksrelaties
DAPP	Dynamic Adaptive Policy Pathways
DPRA	Delta Programma Ruimtelijke Adaptatie
I&W	Ministerie van Infrastructuur en Waterstaat
GRP	Gemeentelijk Rioleringsplan
NAS	Nationale Adaptatie Strategie
OPR	Omgevingsprogramma Riolering
PBI	Plan- en Besluitvormingsproces Infrastructuur
PP	Permeable pavement
SAPP	Spatial Adaptive Policy Pathways
UA	Uitvoeringsagenda
WRA	Water retention area

# List of Figures

Figure 1.1	Solution Map for the Rivierenbuurt, Amsterdam. . . . .	3
Figure 1.2	Adaptive Pathways by Haasnoot et al. (2013). . . . .	5
Figure 1.3	Dynamic Adaptive Policy Pathways approach by Haasnoot et al. (2013). . . . .	6
Figure 2.1	Hydrological units in Amsterdam with study area Bosleeuw in hydrological unit Bos en Lommer. . . . .	10
Figure 2.2	Solution Map for Bos en Lommer, Amsterdam. . . . .	11
Figure 2.3	Surface type use of the urban area Bosleeuw. . . . .	12
Figure 2.4	Residential buildings including those owned by housing corporations in Bosleeuw. . . . .	12
Figure 2.5	Flood depth after 120 mm in one hour in Bosleeuw. . . . .	13
Figure 2.6	Physiological equivalent temperature in 2015 and expected physiological equivalent temperature in 2050 in Bosleeuw. . . . .	13
Figure 2.7	Distance of walking route to cool place in meters in Bosleeuw. . . . .	13
Figure 3.1	Schematic water balance model for case study. . . . .	20
Figure 4.1	Projection of increased challenge in the Netherlands as a result of more rapid climate change. . . . .	28
Figure 4.2	Ambitions for a water robust and climate resilient design of the Netherlands formulated in the DPRA. . . . .	29
Figure 4.3	Location of Amsterdam in the twelve provinces and the Netherlands. . . . .	30
Figure 4.4	The twenty-one water boards in the Netherlands and the three water boards with administrative areas in Amsterdam. . . . .	30
Figure 4.5	Administrative areas of three water boards in Amsterdam and the case study area located in water board Amstel, Gooi en Vecht. . . . .	31
Figure 4.6	Roles and spatial domains of the involved governmental organizations and the plot owner for Bosleeuw. . . . .	32
Figure 4.7	New guidelines for preventing pluvial flooding established in the Implementation Agenda ( <i>Uitvoeringsagenda</i> ). . . . .	33
Figure 4.8	Design standards defined in policy by the municipality of Amsterdam as summarized in the Implementation Agenda. . . . .	34
Figure 5.1	Possible locations of measures included in the pathways following the DAPP approach. . . . .	40
Figure 5.2	Storage capacity in study area in current situation and potential storage capacity per measure. . . . .	42
Figure 5.3	Potential storage capacity for the six selected design alternatives. . . . .	43
Figure 5.4	Pathway map showing pathways for design alternatives S1-S6 for the case study of Bosleeuw, following the DAPP approach. . . . .	44
Figure 5.5	Legend of pathway map with modified set-up in Figure 5.6. . . . .	47

Figure 5.6	Pathway map showing pathways for design alternative for the case study of Bosleeuw, in modified set-up. . . . .	48
Figure 5.7	Cumulative fast storage created per implementation step for each measure. . . . .	49
Figure 5.8	Illustration of the new progress objective that is indicated with the new timeline in the pathways with the modified set-up. . . . .	53
Figure 5.9	Expected moment of renewal of pavement in the public space for the case study of Bosleeuw. . . . .	54
Figure 5.10	Pathway map showing discontinued pathways for the implementation of the design under the renewal strategy, following the timing of renewal of pavement. . . . .	55
Figure 5.11	Illustration that shows that objective will not be reached before $\pm 2060$ and the consequential inability to define the adaptation tipping points. . . . .	56
Figure 5.12	Expected moment of maintenance of pavement in the public space for the case study of Bosleeuw. . . . .	57
Figure 5.13	Pathway map showing pathways for the implementation of the design under the renewal strategy, following the timing of maintenance of pavement. . . . .	58
Figure 5.14	Rates of change in cumulative storage capacity for the implementation according to the renewal strategy, for the renewal of pavement (a, b), maintenance of pavement (c, d) and the renewal of sewer (e, f). . . . .	60
Figure 6.1	Surface types of the urban areas for Bosleeuw, Amsterdam West and Amsterdam, differentiating between buildings, paved surface, green space and surface water. . . . .	68

# List of Tables

Table 3.1 List of policy documents included in the policy analysis. . . . . 17

Table 4.1 Summary of national policy documents for climate adaptation and water management . 27

Table 5.1 Climate predictions for increased precipitation intensity for rainfall event of 60 minutes in the Netherlands. . . . . 38

Table 5.2 Durations of decision-making and execution process and other characteristics of the locations of the measures per implementation step . . . . . 50

# Table of Content

<b>Abstract</b> .....	<b>vii</b>
<b>Abbreviations</b> .....	<b>viii</b>
<b>List of Figures</b> .....	<b>x</b>
<b>List of Tables</b> .....	<b>xii</b>
<b>Introduction</b> .....	<b>2</b>
1.1 Urban climate adaptation .....	2
1.1.1 Amsterdam .....	2
1.2 Adaptive Pathways .....	4
1.3 Research objective .....	7
<b>Case study</b> .....	<b>9</b>
2.1 Case study description .....	10
2.2 Area analysis .....	12
<b>Methodology</b> .....	<b>15</b>
3.1 Planning process for spatial redesign .....	16
3.1.1 Stakeholder analysis .....	16
3.1.2 Policy analysis .....	16
3.1.3 Planning process in Amsterdam .....	17
3.2 Pathway development + exploration .....	18
3.2.1 Pathway development .....	18
3.2.1.1 Objective and uncertainty .....	18
3.2.1.2 Problem analysis .....	18
3.2.1.3 Identify measures .....	18
3.2.1.4 Effectiveness of measures .....	19
3.2.1.5 Development of adaptive pathways .....	19
3.2.2 Exploration of possible modifications .....	19
3.2.2.1 Determining implementation time .....	19
3.2.3 Water balance model. ....	19

<b>Results SQ1</b>	<b>25</b>
4.1 National level	26
4.1.1 Roles and responsibilities	26
4.1.2 Policies and regulation	26
4.2 Regional level	28
4.2.1 Roles and responsibilities	28
4.3 Amsterdam	29
4.3.1 Roles and responsibilities	29
4.3.1.1 Case-study: Bosleeuw	31
4.3.2 Policies and regulation	32
4.3.3 Planning and decision-making process	33
4.4 Findings	36
<b>Results SQ2</b>	<b>37</b>
5.1 Pathway development	38
5.1.1 Objective and uncertainty	38
5.1.1.1 Pluvial flooding objective in Amsterdam	38
5.1.1.2 Rainwater processing capacity	39
5.1.1.3 Spatial aspects	39
5.1.2 Problem analysis	39
5.1.3 Identify measures	40
5.1.4 Effectiveness of measures	42
5.1.5 Adaptive pathways	43
5.1.6 Findings	45
5.2 Modified set-up of pathways	47
5.2.1 Modified pathway set-up	47
5.2.1.1 Implementation time	47
5.2.1.2 Incremental steps	49
5.2.1.3 Duration of implementation time	49
5.2.1.4 Shared adaptation tipping points	52
5.2.1.5 New time-objective relation	52
5.2.2 Other conditions	53
5.2.2.1 Renewal strategy	54
5.2.4 Findings	62

5.3	Contribution to planning process. ....	63
<b>Discussion</b> .....		<b>65</b>
6.1	Limitations of approach. ....	66
6.1.1	SQ1 .....	66
6.1.2	SQ2 .....	66
6.2	Spatial scale .....	67
6.3	Comparison to previous work .....	68
6.4	Transferability .....	68
<b>Conclusion</b> .....		<b>71</b>
<b>Recommendations</b> .....		<b>75</b>
<b>Bibliography</b> .....		<b>78</b>
<b>Appendix A</b> .....		<b>80</b>
1	Plan- en Besluitvormingsproces Infrastructuur. ....	81
<b>Appendix B</b> .....		<b>82</b>
1	Solution space: generated sequences of actions .....	83
2	Alternatives to the realisation of measures in the study area .....	84
3	Contribution per measure for each pathway .....	85
4	Realisation of the measures divided over implementation steps. ....	86
5	Ownership of the rooftop spaces for the implementation steps BG I-VI and G I-II. ....	86
<b>Appendix C</b> .....		<b>87</b>
1	Surface coverage Bosleeuw and Amsterdam .....	88

Chapter 1

# **Introduction**



## 1.1 Urban climate adaptation

The risk of pluvial flooding, heat stress and drought are enhanced due to the changing climate. Cities are particularly vulnerable to these risks because of growing urban population and highly concentrated and growing presence of assets, infrastructures and socioeconomic activities (Geneletti & Zardo, 2016; Voskamp & Ven, 2015). The built environment of urban areas is unable to process the increasing precipitation extremes and pluvial flooding causes damage to housing and infrastructures, resulting in high cost. The built environment is prone to the urban heat island (UHI) effect, which enhances the temperatures in cities significantly. This puts people's comfort and health at risk during heat waves. And lasting precipitation deficits in dry periods can cause soil dehydration, which troubles urban areas and surrounding environments with subsidence, salt intrusion, damage to underground foundations, harm to vegetation and water quality issues.

Evidently, the quality of life in cities is negatively influenced by these climate stresses of cities. National and local administrations are confronted with pressing and challenging issues and high costs if nothing is done to counter these stresses in the urban environment.

To protect the urban environment from these stresses, there is an urgent need to invest in strategic solutions that deliver sustainable, climate resilient long-term outcomes (Brown, Keath & Wong, 2009). Resilience is defined as "the ability of a system to adjust in the face of changing conditions" by Picket et al. (2004). A resilient and sustainable strategy, therefore, must be adequate under various future scenarios and requires an adaptive, flexible character to deal with uncertain future developments (Offermans, Haasnoot & Valkering, 2015).

As noted by Voskamp and Van de Ven, resilient strategies tend to be those in which measures to fight climate stresses are combined and implemented coherently (2015). Hence, it is important that blue and green infrastructures

are combined, and that increased storage capacity is linked to water shortage and heat stress (Voskamp & Van de Ven, 2015).

### 1.1.1 Amsterdam

In the city of Amsterdam, effort is put in the transition to a climate resilient urban environment. In 2011, the water company and water board in Amsterdam experienced a wake-up call: the city of Copenhagen was hit by 150 millimetre of rain in two hours and was faced with almost a billion euros of damage to the city's infrastructure. The realization that such an event could also hit Amsterdam put Waternet into action and in 2014 the program Amsterdam Rainproof was created for the objective of transforming Amsterdam into a rainproof city by 2050. Through stimulating blue-green fine-grained solutions throughout the public and private space in the city, Amsterdam was to become not only rainproof, but also greener and more liveable (Amsterdam Rainproof, n.d.).

Furthermore, the municipality of Amsterdam was recently obligated by the national Delta Program to formulate an implementation agenda for its plans to make Amsterdam water robust and climate adaptive. A new municipal program was set up to integrate climate adaptation in the official (*ambtelijke*) structures and work methods. One of the goals of this program was to formulate the implementation agenda, tackling the four challenges of climate resilience (pluvial flooding, fluvial flooding, heat, and drought) with plans of immediate action and visions to uphold for the future (Gemeente Amsterdam, 2021).

Both Waternet and the municipality now acknowledge the urgency and value of climate resilience. All spatial designing processes must be water robust as a standard; doing otherwise is the exception (Gemeente Amsterdam, 2021; Waternet, 2016). Inspiration documents, guidelines and tools have been created to support the step from the intention of becoming climate resilient, to actually being resilient in the city of Amsterdam.

An example of this approach is the Solution Map. Heavy rainfall in 2014 caused large flooding depths in the low area of one of the neighbourhoods in the city, the Rivierenbuurt, which instigated the creation of a Solution Map as a new tool for this area and later for areas with other rainwater bottlenecks as well. Figure 1.1 shows the Solution Map for the Rivierenbuurt. These maps, published in 2017, identify opportunities for water storage and designate streets for distribution and discharge of water to reach a storage or discharge location. They offer a guiding tool for redesign of public space to enhance coherency in the urban water system at hydrological unit scale and to inform designers and policymakers about rainwater (and climate) resilient local design (Waternet, 2017).

In 2018, an Integrated Method for Design of Public Space was developed and released for all designers and planners in the city's administration to use. It is an integrated method for the sustainable design of public and underground space in the complex urban environment that considers urban systems of

energy, underground soil, water, liveable space, flora and fauna, materials, and mobility (Gemeente Amsterdam, 2018). It serves to translate complex spatial tasks for the design of public space into concrete integral sustainable street profiles and aims to increase cost efficiency and reduce the risk of missteps in (re)design (Gemeente Amsterdam, 2018).

In 2021, another inspiration document was published by the municipality, titled the Work method for Spatial Climate Adaptation, that serves as inspiration for designers of public space, urbanists, or engineers. Following the phases of design, it lists sources of information to regard during the problem analysis, sets ambitions to uphold during the determination of the design objectives and formulates the main principles of action to build up the project requirements (Gemeente Amsterdam, 2021). All three above-mentioned tools have been made available to all employees of the municipality and Waternet and offer ample, extensive inspiration and design tools for climate resilient spatial design. With all these tools in place, and all the policy documents

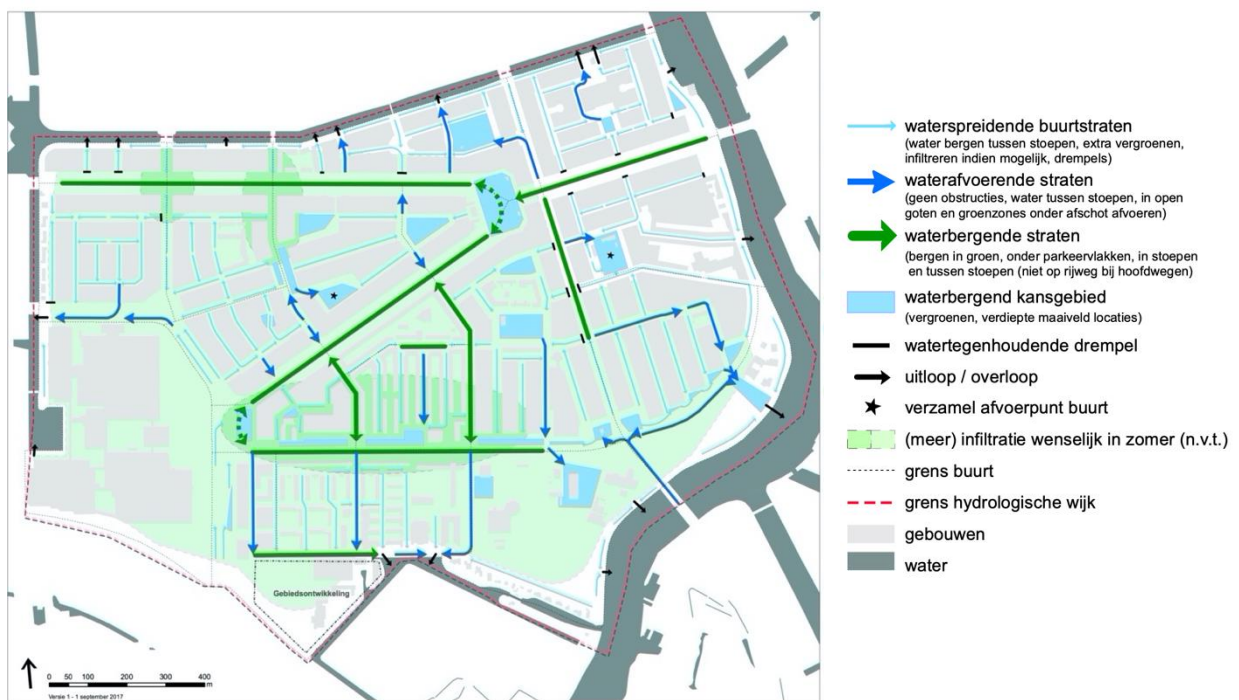

Figure 1.1: The Solution Map (*Oplossingenkaart*) of the Rivierenbuurt, Amsterdam. It illustrates a solution for the retention and discharge of stormwater through identifying designated places for water retention, water discharge and flood-proof street design. Adapted from “Rainproof Oplossingenkaart 40 Rivierenbuurt” by Waternet, 2017.

showing a sense of urgency and consensus for becoming climate resilient as a city, it is remarkable to see the limited progress in concrete neighbourhoods around the city, apart from a few exemplary projects.

Three possible expected reasons for this are given to sketch the context of actualization of climate resilience objectives.

In the first place, there is little room in urban environments to accommodate all claims from diverse functions and interests. Already complex urban environments are filled with underground pipelines and cables and spatial typologies for residence, biodiversity, water storage, recreation, transport. Meanwhile, the population is growing, and urban environments are densifying. Together with increasing climate stresses, it is putting more pressure on scarce urban space. This scarcity could lead to more competition and more frequent prioritization of other urgent needs for space over climate adaptation measures.

Secondly, the physical changes in a city are limited to the rate of change of the built environment. This is called the renewal strategy. The strategy for existing urban areas is that transformations to climate resilient design is not a reason in itself for an area to undergo construction. It is merely a design principle that is adopted in maintenance construction work or re- design, e.g., pipeline maintenance, building construction plans or street profile renewal. This limits the rate at which the transformation to a climate resilient environment takes place.

And thirdly, it proves to be quite difficult to widely implement a new strategy or method in a large governmental body like the municipality, let alone in the situation in which two institutions must work together (the city of Amsterdam and Waternet). New tools or methods are often developed at the executive levels of the organisation, in a bottom-up approach. Getting it widely applied throughout the complex network of employees, teams and programs requires time, effort, mouth-to-mouth lobbying and positive shared experiences with the tools. Only then will the

instrument work its way up in the organisation, where it can be acknowledged, appraised, and approved as an effective and successful approach. Then, the instrument can be given mandate and will be implemented top-down. Implementation of new tools to guide the redesign of urban space is, although not impossible, difficult enough to limit the speed of a transitioning urban environment.

As a result, the city of Amsterdam, like urban areas in general, is not yet climate resilient nor able to adapt to the implications of climate change – pluvial flooding, heat stress and droughts – at the rate in which these stresses have been and are increasing, because the rate of change in the built environment is limited. In this study it is explored if the spatial adaptive policy pathways-method is helpful in mapping out a robust strategy of climate resilience in the face of the limited rate of change in the built environment.

## **1.2 Adaptive pathways**

The Dynamic Adaptive Policy Pathways (DAPP) approach enables adaptive planning and decision-making under deep uncertain conditions (Haasnoot et al., 2013) and can therefore contribute to climate adaptation planning. The DAPP approach is a method for creating adaptive pathways that connect short-term actions while considering long-term objectives and keeping future actions open. The method enables adaptive planning and decision making because it defines multiple sequences of actions between which can be easily moved around in later decisive moments (Haasnoot et al., 2013), depending on changing future conditions.

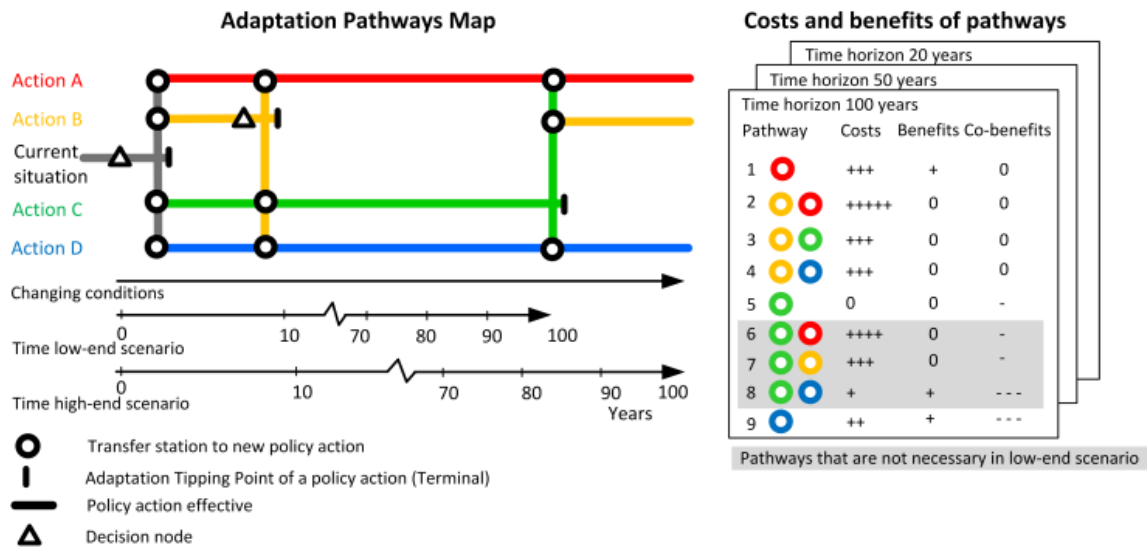

**Figure 1.2:** The visualised adaptive pathways, showing the adaptation tipping points and decision nodes as part of the pathways. The axes show the actions included in a defined measure set on the y-axis and the changing conditions and climate scenarios on the x-axis. Adapted from “Dynamic Adaptive Policy Pathways: A method for crafting robust decisions for a deeply uncertain world” by Haasnoot et al, 2013, p.488

The DAPP approach combines the concepts of Adaptive Policymaking and Adaptive Pathways and adopts adaptation tipping points central to the method (Haasnoot et al., 2019). The concepts are complementary, and the combination of their components form the key principles of the DAPP approach:

- Uncertainties developing over time that are represented by transient scenarios;
- Predefined corrective and anticipating actions that can handle identified vulnerabilities and opportunities;
- Visualized pathways that describe a sequence of actions;
- Monitoring system that tracks identified indicators and trigger values, that connects related actions to reach objectives of pathways (Haasnoot et al., 2013).

The adaptive pathways are visualized in Figure 1.2, showing the pathways with the adaptation tipping points and the decision nodes. Figure 1.3 shows the different steps included in the DAPP approach.

The DAPP approach is an integrated approach that can be used for plan development and that resembles the phases generally defined in the

planning process for area development: exploration, plan development, implementation, and monitoring (Ruimtemet toekomst, 2021). The inclusion of future uncertainties and transient scenarios, that result in pathway thinking, gives the DAPP approach its adaptive character. The following is meant with the terminology used in the graphic of the approach, in Figure 2. A *sell-by date*, otherwise defined as a *tipping point* is the moment where an action or strategy can no longer meet its predefined objective (Kwadijk et al., 2010), and new action should be taken; *contingency actions* are actions to maintain the strategies of the pathways on the track to the set objectives; *triggers* enable the monitoring of this, a trigger event occurs when a *signpost* (i.e., indicator) that tracks pathway performance reaches a *trigger value* (Haasnoot et al., 2013, Raso et al., 2019).

The adaptation tipping points are used to prevent so-called *lock-ins*, i.e., situations where the optional future actions are very limited because of prior decisions (Haasnoot et al., 2019), which lead to inflexibility and incurs additional costs (Raso et al., 2019). The use of tipping points shifts the focus from the circumstances of the climate projections as starting point to the current situation and policy, and thereby expressing uncertainty in

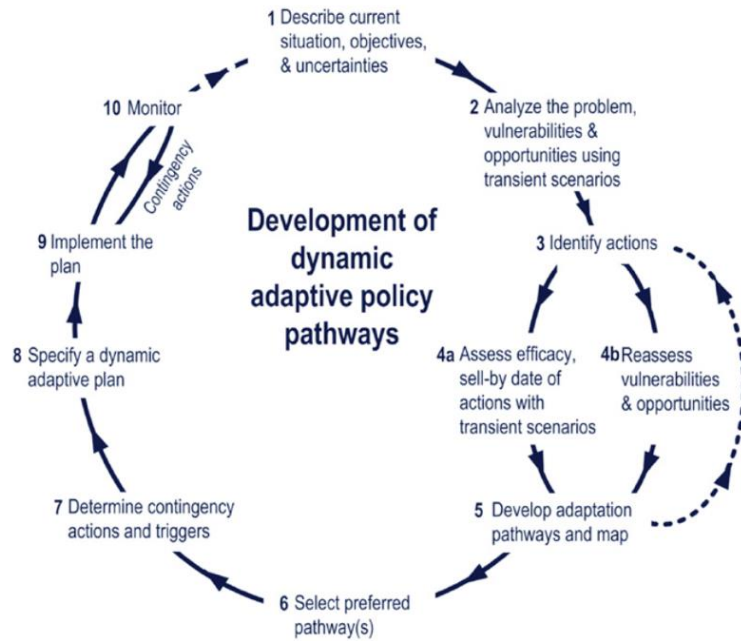

**Figure 1.3:** Dynamic Adaptive Policy Pathways approach. Adapted from “Dynamic Adaptive Policy Pathways: A method for crafting robust decisions for a deeply uncertain world” by Haasnoot et al, 2013, p.489

terms of the period of time in which the current strategy is still effective (Kwadijk, 2010).

Focusing on the existing strategy and its effectiveness under developing uncertain conditions helps identifying short-term influences, decision-moments and actions that need to be prioritized.

Adaptive pathways have been applied in different fields of water management, for example water resources management (Dias et al., 2020; Kingsborough et al., 2016; Manocha and Babovic, 2017); wastewater system planning (Sadr et al., 2020); flood risk management (Bloemen et al., 2018), agriculture (Cradock-Henry et al., 2020), and heat-risk management (Kingsborough et al., 2017). All these studies often refer to the DAPP approach as conceptualized by Haasnoot et al. in 2013, and while some use it as input for applying adaptive pathways (Kingsborough et al., 2016; Kingsborough et al., 2017; Sadr et al., 2020), some adopt the whole approach and apply the dynamic adaptive policy pathways (Manocha and Babovic, 2017; Cradock-Henry et al., 2020; Dias et al., 2020).

Despite the increasing attention for adaptive pathway thinking and planning, little research has been done into the spatial translation of pathway strategies (Zandvoort et al., 2019). In their research, Zandvoort et al. use adaptive pathways to contribute to landscape design and find that spatial design makes the consequences of decisions in pathways transparent by visualizing possible sequences of actions and that it stimulates a valuable iterative research-through-design process (2013).

In continuation of the research of Zandvoort et al. (2019), Liefink combined the addition of a spatial translation and the original DAPP approach of Haasnoot et al. (2013) and applied this so-called Spatial Adaptive Policy Pathways (SAPP) approach to the urban environment of Amsterdam (2021). The SAPP approach consists of the development of pathway maps as well as an analysis of its consequences in water governance. Through analyzing the involved actors and necessary investments for the pathways, Liefink provides insight into the implications of decisions in climate adaptive design and climate adaptation planning on future water governance (2021).

In this study, pathways for the development of a flood resilient waterfront in Havenstad, Amsterdam are made along the rate of sea level rise on the horizontal axis, and the governance implications are analyzed. The possibility of combining multiple climate adaptation themes in a single readable map or to systematically integrate multiple maps of a variety of themes is yet to be researched. Furthermore, the study recommends putting the SAPP method to practice to appraise its applicability in the process of design of the urban environment (Lieftink, 2021).

### **1.3 Research objective**

This research aims to explore how the Dynamic Adaptive Policy Pathways can be used for the rainwater resilient redesign of the existing urban public space in Amsterdam. The planning process of the municipality of Amsterdam for spatial adaptations in the public space and relevant policy documents for climate adaptation and rainwater resilience are analysed to see to what extent the climate stress pluvial flooding is integrated in it. Then, adaptive pathways are developed for a case-study in Bosleeuw, Amsterdam, and a set of modifications is applied to the approach to enhance the functionality of adaptive pathways for the decision-making and implementation for rainwater resilient urban design.

This study aims to answer the following research question:

RQ: How can Spatial Adaptive Policy Pathways contribute to the integration of stress of pluvial flooding the plan process of spatial redesign of existing urban areas?

The main research question is answered through answering two sub-questions:

SQ1: What is the planning process of spatial redesign of existing urban areas in the city of Amsterdam and to what extent is the stress of pluvial flooding integrated in it?

SQ2: How can the adaptive pathways be used for redesigning urban areas to be more resilient to the stress of pluvial flooding?

In the following chapters the research method is described, and the results are presented. In Chapter 2, the case-study for which the adaptive pathways were developed is described. The methodology of this research is elaborated in Chapter 3. In Chapter 4 and 5, the results are discussed, for SQ1 and SQ2 respectively. The discussion is given in Chapter 6 and finally, Chapter 7 and 8 present the conclusions and recommendations.



Chapter 2

# **Case study**



## 2.1 Case study description

To explore how adaptive pathways and the approach of the Dynamic Adaptive Policy Pathways can contribute to rainwater resilient redesign, pathways for a redesign are developed for a case-study area in Amsterdam. The selected neighbourhood is a part of Bosleeuw, an area in Bos en Lommer in Amsterdam West. The study-area is shown in Figure 2.1. The area is identified as an urgent rainwater bottleneck by Amsterdam Rainproof (n.d.), because water accumulates in the streets due to the elevation of the surface level and the surrounding areas.

The map in Figure 2.1 also shows the hydrological units that are defined by Waternet. These are areas that are seen as hydrological entities in which water quantity issues should be resolved, because of the spatial connectivity within the area. The boundaries of these units are often surface water bodies, dikes, main roads or train tracks or green

structures (Gemeente Amsterdam & Waternet, n.d.). It is convenient to regard the urban water system at this scale, hence the research area is at hydrological unit scale. The hydrological unit of Bos en Lommer transcends the neighborhood after which it is named, and covers a part De Baarsjes. Both neighborhoods and the whole of the hydrological unit are located in city district West. The area is enclosed by the Haarlemmervaart, Westelijk Marktkanaal, Kostverlorenvaart, Admiraalgracht, Erasmusgracht and the highway A10.

A Solution Map is made for the hydrological unit of Bos en Lommer. This map is shown in Figure 2.2. In this map, the designated locations for water retention, distribution and infiltration are identified. It serves as a guideline for future spatial adaptations in the public space, indicating how not only the areas for designated water retention and infiltration should be designed, but also how adequate

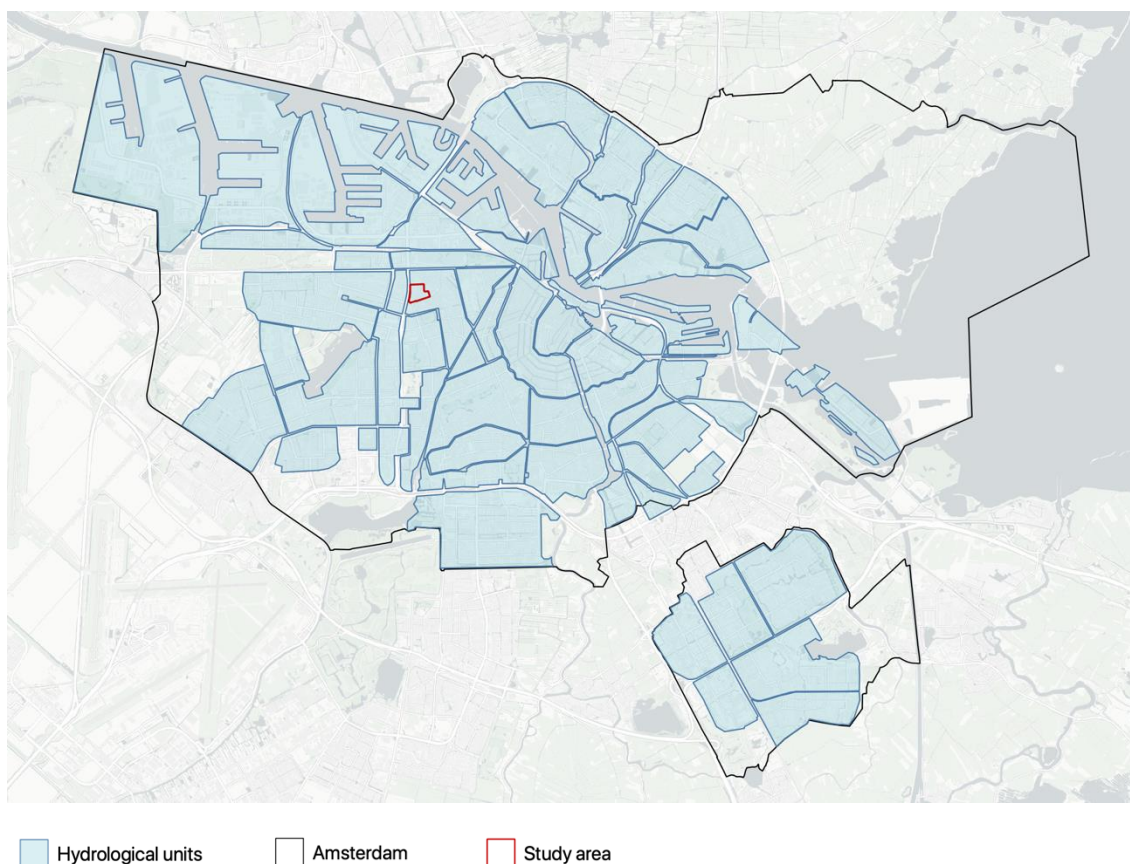

**Figure 2.1:** The hydrological units in Amsterdam with the study area Bosleeuw located in the hydrological unit Bos en Lommer

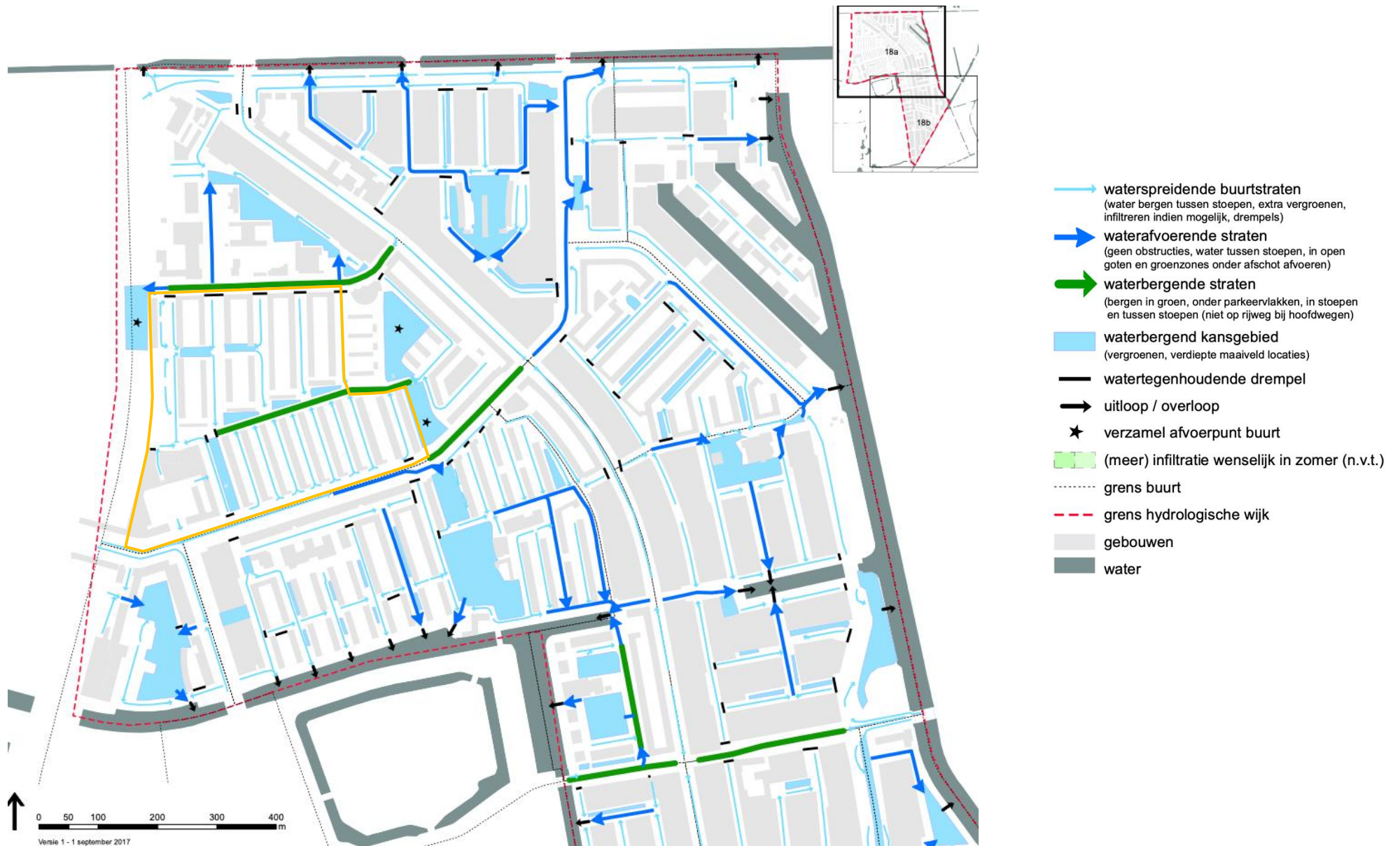

**Figure 2.2:** The Solution Map (*Oplossingenkaart*) of the Rivierenbuurt, Amsterdam. It illustrates a solution for the retention and discharge of stormwater through identifying designated places for water retention, water discharge and flood-proof street design. Adapted from "Rainproof Oplossingenkaart 18a Bos en Lommer" by Waternet, 2017.

street design can benefit the stormwater discharge.

The case-study area is marked in orange in the Solution Map. Six water retention areas are identified within the study area and three larger water retention areas border the study area.

## 2.2 Area analysis

Figure 2.3 shows the shares of paved area, public green area, open water, and built-up area in Bosleeuw. The diagram indicates that the lion's share of the area is impervious, namely the paved and built-up areas. Only a little bit over 10 percent consists of green or blue space. Of the buildings, most 3-story are residential buildings with flat roofs, of which none are registered as green or blue green. This indicates a high potential for water retention on roofs. However, to realise water retention on the roofs at the intensity of blue-green roofs, rooftop renovations would likely be required, as the buildings were built between 1940-1950 (Solcerova, 2021).

Most residential housing is in hands of housing corporation Stadsgenoot, as shown in Figure 2.4 (Gemeente Amsterdam, n.d.). This means that the participation of the housing

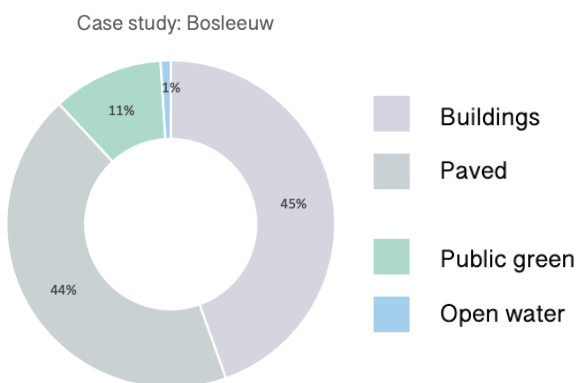

**Figure 2.3:** The surface types of the urban area for Bosleeuw, differentiating between buildings (the share of the total surface area that exists of built-up area (public and private) including yards), paved (the share of the total surface area that exists of unbuilt paved area, such as roads), green space (the share of the total surface area that exists of living green in the public space), and water (the share of the total surface area that exists of inland open water). Adapted from "Gebied in Beeld" by OIS Gemeente Amsterdam (n.d.).

corporation would be required for the realisation of water retention on roofs.

Furthermore, most of the green space is private green, situated between the residential housing blocks. In addition, there is a lot of parking space throughout the area.

Figure 2.5 shows the simulated water accumulation in the streets (in flood depth) after a rainfall event of 120 mm/h on the left (Gemeente Amsterdam, n.d.). It shows the hotspots on the central road and some of the streets in the southern part. The right map shows the area in the south of the study area where the groundwater level is too high to allow for infiltration.

The area marked in grey is the rainwater bottleneck Bosleeuw Midden.

Figure 2.6 shows the experienced heat stress in the area, expressed in the physiological equivalent temperature for a recorded day in 2015 and a predicted similar weather event in 2050 according to the worst-case climate scenario (Klimaat-effectatlas, n.d.).



■ Housing corporations  
■ Other residential buildings

**Figure 2.4:** Residential buildings, including those owned by housing corporations Stadsgenoot and Rochedale in Bosleeuw, Amsterdam.



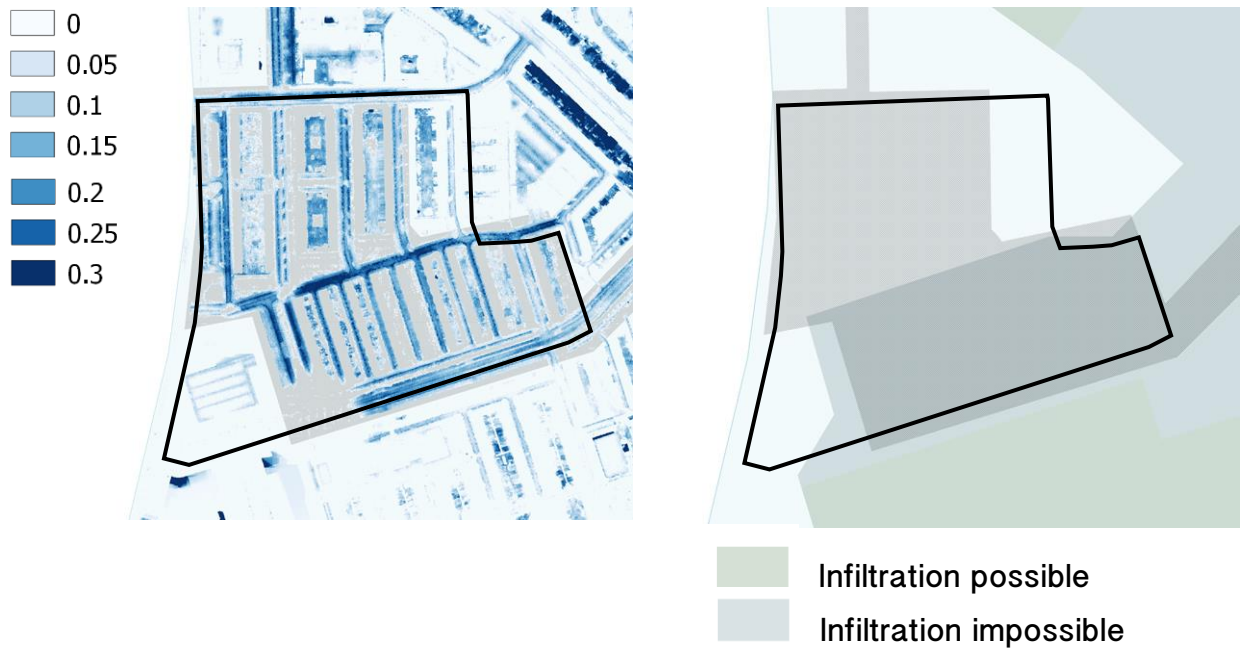

Figure 2.5: Flood depth after 120 mm in one hour in mm in Bosleeuw, Amsterdam (left) and marked area where the groundwater level is high and infiltration is impossible (Gemeente Amsterdam, n.d.)

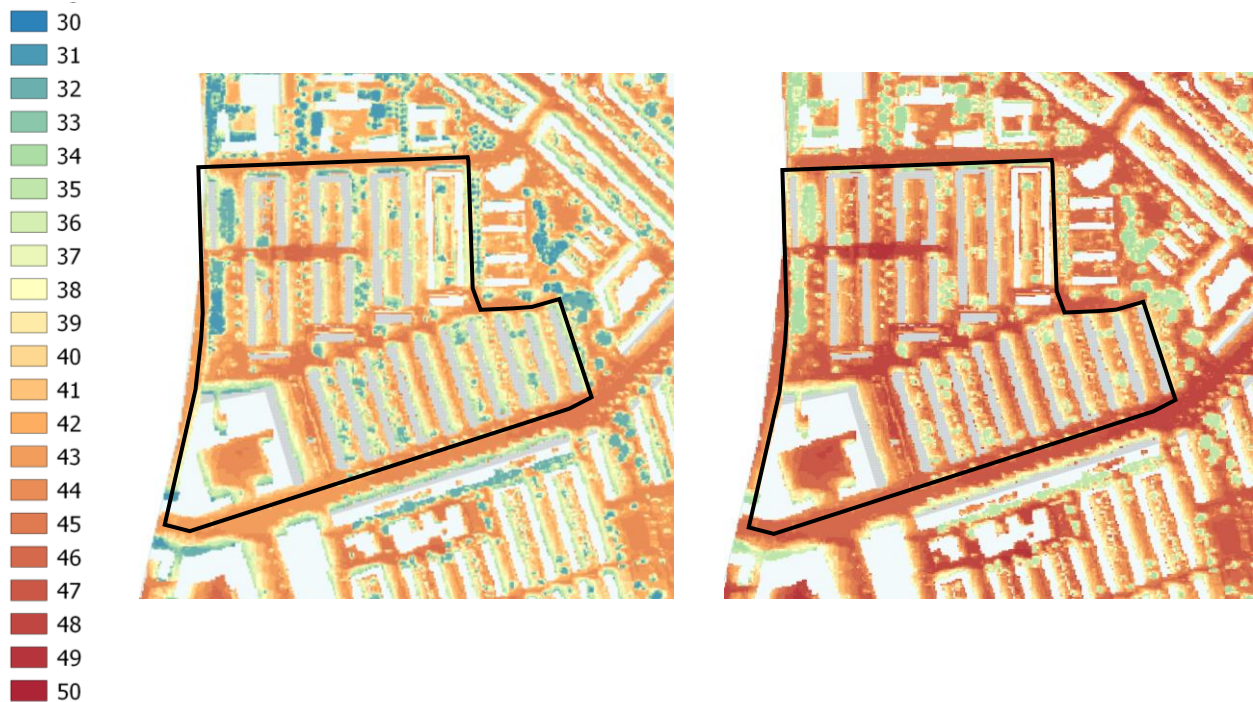

Figure 2.6: Physiological equivalent temperature measured on a summer day with extreme temperatures in 2015 in °C (left) and the expected physiological equivalent temperature during a similar weather event as predicted by the climate scenario 2050H. Adapted from "Kaartviewer – Klimateffectatlas" by Klimateffectatlas, (n.d).



- Cool spot
- 0-200 m distance
- 200-300 m distance
- 300-400 m distance
- 400-500 m distance
- 500+ m distance

**Figure 2.7:** Distance of walking route to cool place in meters in Bosleeuw, Amsterdam.

Chapter 3

# **Methodology**

In this chapter, the research approach is explained, and the methodology of the research steps is elaborated.

The strategy of this study is a qualitative exploration of the potential of the Spatial Adaptive Policy Pathways (SAPP) approach in the context of spatial redesign of existing urban areas. This is done for a case study in Amsterdam. The first part of this study involves analysing the planning process in Amsterdam for spatial redesign and climate. This part consists of multiple steps: identifying the roles and responsibilities of involved organisations (1), analysing the relevant key policies (2), and analysing the planning process for redesign of the public space (3). The second part of the study involves the explorative design of adaptation pathways. This was done by developing pathways for the study area Bosleeuw (a neighbourhood in Bos en Lommer, Amsterdam) and exploring alternatives and improvements for the pathway approach to contribute to climate adaptive redesign.

In this chapter, the set-up and methods of the research are explained per research step. In addition to the research methods described in the next sections, the insights presented in this research were partly derived from an internship at the municipality of Amsterdam and employment at Waternet, the water company in Amsterdam. Over the course of seven months at the municipality and thirteen months at Waternet, knowledge was acquired about climate adaptation, rainwater resilience, the planning process, and the roles of various organisations and departments in Amsterdam. Throughout the internship and employment, the program Amsterdam Rainproof was actively engaged with. Additionally, meetings of the municipality's Climate Adaptation program were attended during the internship. As the research topic coincides with the theme of the work, insights gained from observations, participation, and other interactions could be applied in the research.

Furthermore, findings were validated with expert input, mainly provided by Daniël Goedbloed. With over 23 years of experience working for the municipality of Rotterdam and

Waternet, Goedbloed holds substantial expertise in rainwater resilience and climate adaptation planning. Throughout the research, Goedbloed's expert feedback and validation was utilized to ensure the accuracy and reliability of the research findings.

### **3.1 Planning process for spatial redesign**

This part of the research answers the first sub-research question:

SQ1: What is the planning process of spatial redesign of existing urban areas in the city of Amsterdam and to what extent are the stresses of pluvial flooding, heat and drought integrated in it?

#### **3.1.1 Stakeholder analysis**

The roles and responsibilities of involved governmental organisations for climate adaptation and spatial planning were identified. Organisations involved in the developing of policies, regulations and guidelines and involved in the implementation of plans were considered. This was done at a national and regional level and at the level of Amsterdam. The identification of the roles and responsibilities of the stakeholders primarily relied on literature on the organisational and judicial structures of the Dutch water system and spatial planning by Mostert (2022) and Al (2022). Additionally, insights were derived from information on the websites of the organisations involved. To ensure the reliability of the results, the findings were validated with expert input.

#### **3.1.2 Policy analysis**

The policies for climate adaptation and spatial planning and design that are relevant for climate adaptation planning and redesign in urban areas, and specifically for pluvial flooding, were analysed. This was also done at a national and regional level, and at the level of Amsterdam. The relevant policy documents were obtained from information on the websites of the governmental organisations involved. Table 3.1 shows the policy

documents that were included in the analysis. The quality of the grey literature was assessed through the following considerations: a) only policies formed and published by the governmental organisations themselves were considered; b) policy documents that are recently published or referenced to as relevant, by the governmental organisations involved and c) the list of policies included was validated by expert input. The grey literature was analysed to see to what extent the climate stresses, and specifically pluvial flooding, are included in it. This analysis facilitated an understanding of the policy guidelines and obligations that are in effect, concerning climate- and rainwater resilience.

In Table 3.1, the last set of documents, under 'Included in IA', are policy documents that are discussed in the Implementation Agenda. The policy guidelines concerning pluvial flooding are summarized in the Implementation Agenda and were thus included in the policy analysis.

### 3.1.3 Planning process in Amsterdam

To understand the planning process for spatial redesign of the existing urban space, the work process defined for spatial adaptations in the public space was analysed. This work process is defined in the *Plan- en Besluitvormingsproces Infrastructuur* (PBI) which establishes the process for maintenance, renewal, and replacement of the infrastructure in the public space (Gemeente Amsterdam, 2019). This document was analysed to see to what extent the climate stresses, and specifically pluvial flooding are included in it. Furthermore, it was examined how the PBI relates to the policy documents discussed in the policy analysis, to understand the degree of obligation and actualization of the policy guidelines within the planning process for spatial redesign. The results of this research step were validated with expert input.

**Table 3.1:** A list of policy documents that were included in the policy analysis, ordered by organizational level (national level, regional level, municipal level) and including the author(s) and the year of publication.

Level	Policy document	Author(s)	Year
National level	National Climate Adaptation Strategy 2016 (NAS) <i>Nationale Adaptatie Strategie</i>	Ministerie van Infrastructuur en Milieu	2016
	Implementation Program NAS 2018-2019 <i>Uitvoeringsprogramma NAS</i>	Ministerie van Infrastructuur en Waterstaat	2018
	Delta program 2023 <i>Deltaprogramma</i>	Ministerie van Infrastructuur en Waterstaat; Ministerie van Landbouw, Natuur en Visserij; Ministerie van Binnenlandse Zaken en Koninkrijks Relaties	2022
Amsterdam	Coalition Agreement 2022 <i>Coalitieakkoord</i>	Gemeente Amsterdam	2022
	Implementation Agenda Climate Adaptatie (IA) <i>Uitvoeringsagenda Klimaatadaptatie</i>	Gemeente Amsterdam	2020
	Municipal Sewer Plan 2022-2027 <i>Omgevingsprogramma Riolering</i>	Gemeente Amsterdam	2022
	Plan- en Besluitvormingsproces Infrastructuur	Gemeente Amsterdam, Verkeer & Openbare Ruimte	2019
Included in IA	Visie Openbare Ruimte 2025	Gemeente Amsterdam	
	Handboek Rood 2019	Gemeente Amsterdam	
	GRP 2016-2022	Gemeente Amsterdam	
	AGV Keur 2019	Gemeente Amsterdam	
	Puccini Methode 2019	Gemeente Amsterdam	
	Hemelwaterveordening 2021	Gemeente Amsterdam	



## **3.2 Pathway development + exploration**

This part of the research answers the second sub-research question:

SQ2: How can the adaptive pathways be used for redesigning urban areas to be more resilient to the stress of pluvial flooding?

This question was answered through two steps: developing pathways by spatially applying the Dynamic Adaptive Policy Pathways approach by Haasnoot et al. (2013) to see how these adaptive pathways can be used for rainwater resilience (1) and exploring alternatives and possible improvements to the pathways to find out how adaptive pathways can contribute to climate adaptation planning in Amsterdam (2). In both steps, the pathways were developed for the case study in Bosleeuw.

This part of the research is an explorative design phase: through designing pathways and exploring alternative possibilities new knowledge was created on the possible contribution of adaptive pathways for the case study and climate adaptation planning in general. This methodological approach is based on the concept 'research by design'. This is a research method that involves a design process to explore and investigate potential solutions through a series of design experiments. It provides a philosophical and normative framework for the design process, but also allows for unexpected and exploratory paths (Roggema, 2016).

Both the development of the pathways (step 1) and the exploration of alternatives (step 2) built upon following the policymaking and design approaches:

- i) Dynamic Adaptive Policy Pathways (DAPP) by Haasnoot et al. (2013)
- ii) Spatial Adaptive Policy Pathways (SAPP) for a case study in Haven-Stad by Liefink (2020)
- iii) Adaptation Pathways (AP) by Haasnoot et al. (2012)

## **3.2.1 Pathway development**

The adaptive pathways were developed for the case study based on steps 1-5 from the DAPP approach (Haasnoot et al, 2013). Section 3.2.1.1 to section 3.2.1.7 describe the different steps that were taken to create the pathways.

### **3.2.1.1 Objective and uncertainty**

First, the key objectives for making Amsterdam more resilient to the stress of pluvial flooding were identified. The ambitions for rainwater resilience and preferred solution types were derived from the municipal sewer plan and other policy guidelines that were included in the policy analysis.

Then, the relevant uncertain development was identified. In this case, the expected increase in rainfall intensity due to the changing climate was selected as the most influential uncertain development.

### **3.2.1.2 Problem analysis**

In this step, the current situation in the case study area was compared to the specified objective for rainwater resilience. This was done to identify spatial characteristics of the current situation and to determine the needs for action.

### **3.2.1.3 Identify measures**

A set of possible measures was created based on the outcomes of the problem analysis. Then, the measures were applied in design alternatives for rainwater resilient design for the case study.

The selection of measures was based on the following considerations. Firstly, the municipality has defined preferred solution types for rainwater processing. Secondly, a degree of familiarity with different rainwater processing measures was derived from available data of Amsterdam Rainproof and the municipality of Amsterdam. It was chosen to create a set of measures that are already (widely) applied in Amsterdam. Lastly, the Solution Map for the neighbourhood Bos en Lommer was considered as a guideline for the rainwater resilient design.

#### **3.2.1.4 Effectiveness of measures**

In this step, the effectiveness of the measures was assessed using a water balance model. This model is described in Section 3.2.2. With this assessment, the sell-by dates of each action and set of actions was determined by comparing the effectiveness of the measures to the set objective that develops over time. The effectiveness of the measures was expressed in added storage capacity in  $m^3$ . The sell-by date is the moment in time when the (set of) action(s) is no longer effective in reaching the objective. At this point in time, the adaptation tipping point occurs (Haasnoot et al., 2013). The different set of actions considered form the design alternatives for which the pathways can be developed.

#### **3.2.1.5 Development of adaptive pathways**

The different design alternatives were developed into pathways and a pathway map was formed. The design alternatives, composed of a sequence of actions, were plotted into the pathway map, illustrating the adaptation tipping points. The pathway map was illustrated similarly to the map presented in the DAPP approach (Haasnoot et al., 2013).

### **3.2.2 Exploration of possible modifications**

In response to the findings of the development of the DAPP pathways, possible modifications to the set-up of the pathways were explored. The objective of this explorative phase was to increase the usability of the concept of adaptive pathways in the context of the planning process in Amsterdam.

A series of adjustments were combined in a new version of the adaptive pathways and the pathway map. Thereafter, the adjusted approach was used to develop pathways for the case study under different conditions, to test its usability. Firstly, a set of pathways was created under the condition of the renewal strategy (see Chapter 1, Section 1.1.1). Secondly, new pathways were developed under the condition of minimizing dependence on private space and private parties for realizing rainwater storage. And lastly, a set of pathways was made that include other types of measures that are not spatial adaptations.

#### **3.2.2.1 Determining implementation time**

For the modified pathway set-up, the duration of the implementation process of each measure was estimated. For the measures in the public space, the duration of the decision-making process and the execution process was estimated based on online available information about similar projects of the municipality of Amsterdam. For the water retention on the roofs, the durations were based on expert input.

#### **3.2.3 Water balance model**

As a support tool for developing the pathways, a water balance model was made. With this model, the effectiveness of the measures was estimated. The effect of measures was expressed in storage capacity. The model consists of storage on roofs, surface level, open water, in the unsaturated zone and in the sewer system, and the fluxes in between. The model is shown in Figure 3.1, including the measure set of green roofs, blue-green roofs, water retention areas and permeable pavement and subsequent storages.

To simplify the model, a set of simplifying assumptions was made. It was assumed that all stormwater must be processed within 60 minutes after the start of the rainfall event. In other words, the considered rainwater storage capacity is the amount of water that can be stored within 60 minutes. In the model, the timestep  $\Delta t$  is still left undefined, however, to be able to see how a longer timestep would influence the storage capacity.

Furthermore, it was assumed that the runoff from the roof surface discharges onto the surface level. From the surface level, it either infiltrates into the subsurface, or runs off onto the open water, into the water retention areas or into the sewer system. Direct flows from roof surfaces to open water or the sewer system were neglected. In addition, the groundwater below the groundwater table, its interaction with the unsaturated zone and drainage into the open water or sewer system were not considered. Neither were interactions between water storage on open

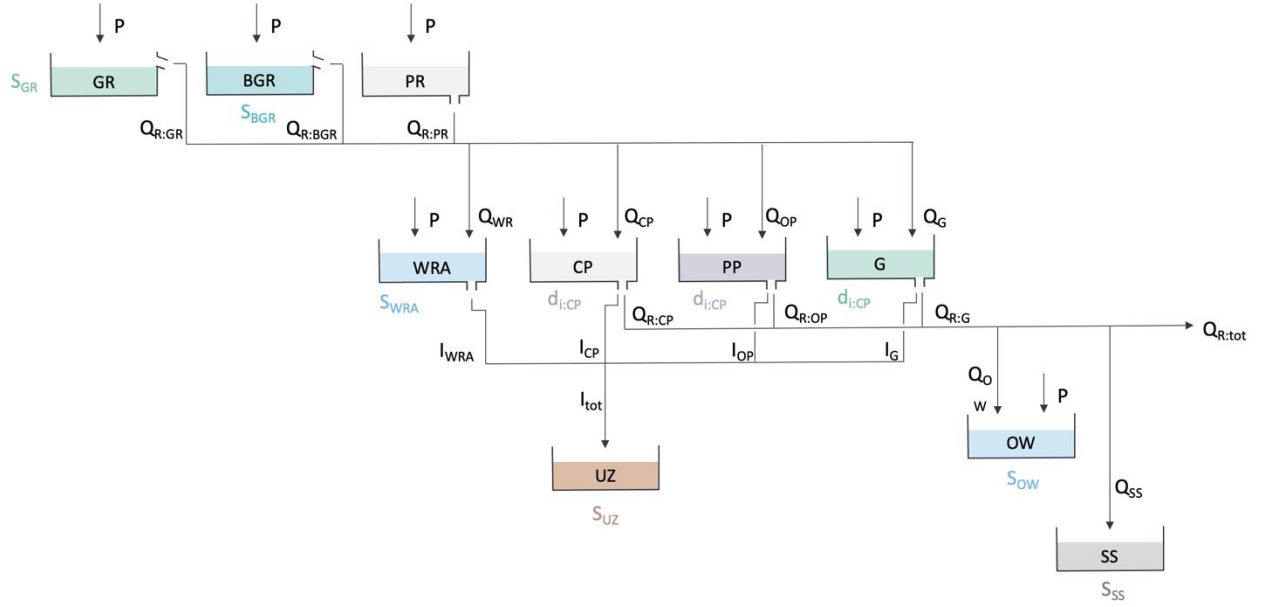

**Figure 3.1:** Schematic water balance model showing the fluxes of precipitation (P), runoff (Q<sub>R</sub>), inflowing stormwater (Q), and Infiltration (I), the storages (S) and the elements: green roofs (G), blue-green roofs (BGR), paved roofs (P), water retention areas (WRA), closed pavement (CP), permeable pavement (PP), green space (G), unsaturated zone (UZ), open water (OW) and the sewer system (SS).

water and the unsaturated zone. Furthermore, the evapotranspiration was neglected.

#### Window of time

The considered window of time for which the fluxes in the water balance model are calculated is  $\Delta t$ .

#### Precipitation

The total precipitation depth  $P$  is given in  $mm$ . It is the amount of precipitation that falls in one hour, as the precipitation event that is considered has a duration of 60 minutes.

#### Green roofs

The available water retention on green roofs is expressed with  $S_{pot:GR}$ , the total potential storage of all the green roofs in the area in  $m^3$ , and is determined with Equation 5.1.

$$S_{pot:GR} = s_{c:GR} * A_{GR} \quad (5.1)$$

Here, the specific storage capacity of green roofs  $s_{c:GR}$  is assumed to be  $30 \text{ mm}$  ( $30 \text{ L/m}^2$ ) (De Dakdokters, 2022). The total area of all green roofs in the study area is given by  $A_{GR}$  in  $m^2$ .

The actual storage on green roofs in  $m^3$  is given by  $S_{GR}$  and is determined with Equation 5.2.

$$S_{GR}(t) = \begin{cases} P * A_{GR} & \text{if } P < s_{c:GR} \\ S_{pot:GR} & \text{if } P \geq s_{c:GR} \end{cases} \quad (5.2)$$

The actual storage is determined under the assumption that there is no water stored at the beginning of a rainfall event and the total potential storage is available for water retention.

The runoff from green roof surface  $Q_{R:GR}$  in  $m^3$  is determined by Equation 5.3.

$$Q_{R:GR} = \begin{cases} 0 & \text{if } P < s_{c:GR} \\ P * A_{GR} - S_{GR} & \text{if } P \geq s_{c:GR} \end{cases} \quad (5.3)$$

#### Blue-green roofs

The potential storage on blue-green roofs in  $m^3$  is given by  $S_{pot:BGR}$  in Equation 5.4.

$$S_{pot:BGR} = s_{c:BGR} * A_{BGR} \quad (5.4)$$

Here, the specific storage capacity of blue-green roofs  $s_{c:BGR}$  is assumed to be  $100 \text{ mm}$ . The total area of blue-green roofs in the study area is given by  $A_{BGR}$  in  $m^2$ .

The actual storage  $S_{BGR}$  in  $m^3$  is determined with Equation 5.5, also under the assumption that no water is stored at the beginning of a rainfall event and the total potential storage is available.

$$S_{BGR}(t) = \begin{cases} P * A_{BGR} & \text{if } P < S_{c:BGR} \\ S_{pot:BGR} & \text{if } P \geq S_{c:BGR} \end{cases} \quad (5.5)$$

The runoff from blue-green roof surface  $Q_{R:BGR}$  in  $m^3$  is determined by Equation 5.6.

$$Q_{R:BGR} = \begin{cases} 0 & \text{if } P < S_{c:BGR} \\ P * A_{BGR} - S_{BGR} & \text{if } P \geq S_{c:BGR} \end{cases} \quad (5.6)$$

#### Paved roofs

The surface classification ‘paved roofs’ considers all roofs without water retention facilities or water retaining vegetation. The interception of rainwater on these roofs is neglected. As a result, there is no storage on the paved roofs included in the model. Therefore, the runoff from the paved roofs  $Q_{R:PR}$  in  $m^3$  is determined by Equation 5.7.

$$Q_{R:PR} = P * A_{PR} \quad (5.7)$$

#### Unsaturated zone

In the water balance model, the subsurface is modelled with an unsaturated zone with homogeneous characteristics throughout the area. The unsaturated zone is the zone between the surface level and the groundwater level. Deeper groundwater is neglected and other interactions than infiltration into the unsaturated zone are not considered.

The average depth between the surface level and the groundwater level in the area is 100 *cm*, and the soil underneath the paved surface is a sandy soil. To determine the infiltration capacity of this layer, it is assumed that the infiltration capacity is equal to the hydraulic conductivity of the soil. A value for  $K_S$  of 1 *m/d* is found in literature (Bear, 1975, as cited in Norris et. al, 2016). Converted into millimetres per hour this gives an infiltration capacity  $I_C$  of 42 *mm/h*.

A storage coefficient  $\mu$  of 10% is assumed, which means that 10% of the volume of the sandy soil layer is available for rainwater storage. This is lower than the porosity of sand, which is about 30-40%, as the pores of the soil are already partly filled with water in the unsaturated zone. The storage coefficient  $\mu$  of 10% for an unsaturated soil layer of 100 *cm* translates to a specific storage capacity  $S_{c:UZ}$  of 100 *mm*.

The storage in the unsaturated zone  $S_{UZ}$  in  $m^3$  is determined with by Equation 5.8.

$$S_{UZ} = (I_{CP} * A_{CP} + I_{OP} * A_{OP} + I_G * A_G + I_{WRA} * A_{WRA:i}) \quad (5.8)$$

It is the sum of the amount of infiltration into the unsaturated zone from the closed pavement, open pavement, green surface and water retention areas. The infiltration  $I_{CP}$ ,  $I_{OP}$ ,  $I_G$ , and  $I_{WRA}$  in *mm* are determined by Equations 5.9, 5.11, 5.13, and 5.14, respectively. The infiltration is multiplied by the surface area through which the rainwater infiltrates, indicated with  $A_{CP}$ ,  $A_{OP}$ ,  $A_G$  and  $A_{WRA:i}$ . The latter is not the surface area of all water retention areas, but only where infiltration is facilitated.

The storage in the unsaturated zone  $S_{UZ}$  is determined under the assumption that there is no prior rainwater stored in the unsaturated zone at the beginning of a new rainfall event, i.e., that the full storage capacity is available for water storage.

#### Closed pavement

The interception on the closed pavement, the inception is assumed to be 10 *mm*, denoted with  $d_{i:CP}$ . The inflow of stormwater runoff from the roofs  $Q_{CP}$  and precipitation  $P$  onto the closed pavement mainly runs off and partly infiltrates into the unsaturated zone, through the small spaces in between the tiles.

The amount of infiltration  $I_{CP}$  in *mm* is determined with Equation 5.9.

$$I_{CP} = \left( P + \frac{Q_{CP}}{A_{CP}} - d_{i:CP} \right) * (1 - C_{CP}) \quad (5.9)$$

The runoff from the roofs onto the closed pavement in  $m^3$  is indicated with  $Q_{CP}$  and the precipitation in  $mm$  with  $P$ . Furthermore,  $C_{CP}$  is the runoff coefficient of closed pavement. For the paved surface, an average value of 0.9 is assumed (Maine government, n.d.). This means that 90% of the water will run off directly, and only 10% will infiltrate, given that the infiltration capacity allows it.

It is assumed that the  $I_{CP}$  does not surpass the  $I_C$ , as 10% of the stormwater is highly unlikely to be more than 42  $mm$ .

The runoff from the closed pavement  $Q_{R:CP}$  in  $m^3$  is determined by Equation 5.10.

$$Q_{R:CP} = P * A_{CP} + Q_{CP} - d_{i:CP} * A_{CP} - I_{CP} * A_{CP} \quad (5.10)$$

#### Permeable pavement

There is no storage considered on the surface with permeable pavement, as the interception is assumed to be zero. As these infiltration facilities are designed to infiltrate stormwater, the inflow of runoff  $Q_{PP}$  and precipitation  $P$  onto the permeable pavement mainly infiltrate into the unsaturated zone. If the inflow of stormwater due to high precipitation intensity exceeds the infiltration rate, however, runoff is generated. The infiltration  $I_{PP}$  in  $mm$  is determined with Equation 5.11, and the runoff from the permeable pavement  $Q_{R:PP}$  is determined with Equation 5.12.

$$I_{PP} = \begin{cases} \left( P + \frac{Q_{PP}}{A_{PP}} \right) & \text{if } P + \frac{Q_{PP}}{A_{PP}} < I_{C:PP} * \Delta t \\ I_{C:PP} * \Delta t & \text{if } P + \frac{Q_{PP}}{A_{PP}} \geq I_{C:PP} * \Delta t \end{cases} \quad (5.11)$$

$$Q_{R:PP} = P * A_{PP} + Q_{PP} - I_{PP} * A_{PP} \quad (5.12)$$

Here,  $I_{C:PP}$  is the infiltration capacity of permeable pavement. This capacity is dependent on the permeability of the pavement layer and of the gravel layer underneath, that allows for more infiltration than the sandy soil underneath the regular pavement. A value of 194  $mm/h$  is adopted for the infiltration capacity of the permeable pavement, which is the objective value for

permeable pavement in the Netherlands (Bogaard & Lucke, 2019).

#### Green surface

For the green surface, the interception is also assumed to be 10  $mm$ .

Runoff  $Q_G$  is generated if the inflow of stormwater exceeds the infiltration rate, i.e., if the precipitation intensity is too high. The amount of infiltration  $I_G$  in  $mm$  is determined with Equation 5.11.

$$I_G = \begin{cases} \left( P + \frac{Q_G}{A_G} \right) & \text{if } P + \frac{Q_G}{A_G} < I_C * \Delta t \\ I_C * \Delta t & \text{if } P + \frac{Q_G}{A_G} \geq I_C * \Delta t \end{cases} \quad (5.11)$$

An important note is that the maximum amount of  $I_G$  in  $mm$  is the specific storage capacity  $S_{c:UZ}$ . If this level is reached, the soil is saturated, and no more water can infiltrate.

$I_C$  is again the infiltration capacity of the sandy soil layer, with the estimated value of 42  $mm/h$ .

The runoff from the green surface  $Q_{R:G}$  is determined with Equation 5.14.

$$Q_{R:G} = P * A_G + Q_G - d_{i:G} * A_G - I_G * A_G \quad (5.14)$$

#### Water retention areas

Water retention areas are designed to retain runoff from a wider catchment in the study area. Depending on the surface area and the possible water depth  $d$ , these retention areas facilitate an amount of potential storage. Through the design of the street profile and through the drainage system, the stormwater can be discharged into these storage facilities. In some of the water retention location, infiltration occurs. The amount of infiltration  $I_{WRA}$  in  $mm$  is determined with Equation 5.15.

$$I_{WRA} = \begin{cases} \left( P + \frac{Q_{WRA:i}}{A_{WRA:i}} \right) & \text{if } P + \frac{Q_{WRA:i}}{A_{WRA:i}} < I_C * \Delta t \\ I_C * \Delta t & \text{if } P + \frac{Q_{WRA:i}}{A_{WRA:i}} \geq I_C * \Delta t \end{cases} \quad (5.15)$$

Here,  $Q_{WRA:i}$  and  $A_{WRA:i}$  are the inflowing runoff and the surface area of the water retention areas where infiltration occurs.

And again, the maximum amount  $I_{WRA}$  in  $mm$  is the specific storage capacity  $s_{c:UZ}$ . If this level is reached, the soil is saturated, and no more water can infiltrate.

The total storage capacity of the water retention areas  $S_{WRA}$  in  $m^3$  is determined with Equation 5.16.

$$S_{WRA}(t) = I_{WRA} + \sum A_{WRA:j} * d_j \quad (5.16)$$

#### Open water

The water retention capacity of the open water is determined with Equation 5.17.

$$S_{OW} = A_{OW} * \Delta h \quad (5.17)$$

Here,  $\Delta h$  is the allowed increase in water depth on the water surface. The typically allowed increase for rainwater storage is 20-30  $cm$ , and the value adopted for  $\Delta h$  is 200  $mm$ .

#### Sewer system

The sewer system in the study area is designed to have a capacity to process 20  $mm$  of rainfall. The discharge capacity of the sewer can be neglected. Thus, the specific storage capacity of the sewer system  $s_{SS}$  is 20  $mm$ . As such, the storage capacity of the sewer system  $S_{SS}$  in  $m^3$  can be estimated with Equation 5.18.

$$S_{SS} = A_{tot} * s_{SS} \quad (5.18)$$



Chapter 4

# Results SQ1



In this chapter the first sub-research question is answered:

SQ1: What is the planning process of spatial redesign of existing urban areas in the city of Amsterdam and to what extent is the stress of pluvial flooding integrated in it?

The relevant stakeholders and policies that influence climate adaptation planning and spatial planning are analysed, to understand how spatial redesigns for urban areas are formed. The roles and responsibilities of the governmental organisations and policies and regulation at the national level, regional level and for Amsterdam are discussed in Sections 4., 4.2 and 4.3, respectively. In Section 4.3, the distribution of roles and responsibilities of the stakeholders in the study area specifically is discussed, as well as the planning and decision-making process of the municipality of Amsterdam for redesign of existing urban public space.

## **4.1 National level**

### **4.1.1 Roles and responsibilities**

Sections 4.1.1 discusses the roles and responsibilities of stakeholders on national level, regarding water management and spatial planning. Section 4.2.1, later on, does so for the regional level. Al (2022) has analysed the roles of stakeholders in the domains of water management and spatial planning, and Mostert (2022) explained organisational framework of the Dutch water system, with the stakeholders and their responsibilities. The relevant remarks are summarized in sections 4.1.1 and 4.2.1 and combined with information published on the websites of the relevant organisations.

At a national level, two ministries of the national government are directly involved with climate adaptation. The Ministry of Infrastructure and Water (I&W) and the Ministry of Internal Affairs and Kingdom Relations (BZK) for respectively the water system and spatial planning. In terms of water management, the national government is

responsible for creating the policy framework and strategic objectives for the Netherlands (Rijkswaterstaat, n.d.). The Ministry I&W creates the national water policy and develops and instates the according regulations (Al, 2022). The current policies that mainly govern Dutch water management are the Deltaplan and specifically the Deltaplan Spatial Adaptation (the *Deltaplan Ruimtelijke Adaptatie*, DPRA), and the National Water Program (the *Nationaal Water Programma*, NWP). These documents and the inclusion of the climate stresses are elaborated in Section 4.1.2. It has outsourced the management of the state waters (the *Rijkswateren*) to its executive service *Rijkswaterstaat* (RWS). The state waters are the North Sea, the Waddenzee, the IJsselmeer and the large rivers and waterways (Mostert, 2022). The Ministry of BZK is responsible for spatial planning and develops policies and regulations for spatial planning and climate adaptation in the built environment (Informatiepunt Leefomgeving, n.d.-a). It also concerns other thematic topics related to climate adaptation, such as area development, liveability of environment and housing (Ministerie van Algemene Zaken, 2023). Its policy is exercised through the National Environment Vision (NOVI) and the Environmental Act, a new overarching law that will be instated that will regulate all spatial developments. These two documents will be further explained in Section 4.1.2.

### **4.1.2 Policies and regulation**

In the following sections, the roles and objectives of policies and regulation relevant for urban climate adaption are summarized. For each piece it is discussed to what extent stress for pluvial flooding is included.

On a national level, there are several policies and strategies created by both the national and regional governments that serve as guidelines for the governments and involved parties. An overview of these policies on national level is given in Table 4.1. Elaboration of the Delta Program and the Environmental Act is given the following paragraphs.

**Table 4.1:** Summary of national policy documents for climate adaptation and water management.

Policy document	Role	Policy points for climate adaptation
National Climate Adaptation Strategy 2016 ( <i>Nationale Klimaatadaptatie Strategie</i> ) (NAS)	The NAS is a national strategy for climate adaptation, in response to EU legislation. It serves to strengthen the awareness of climate adaptation. Together with involved parties and experts, six urgent climate effects and six strategy focus points were defined.	<p>Established objectives (Ministerie van I&amp;M): i) raise awareness of the need to adapt to climate change, ii) promoting the implementation of climate adaptation, iii) utilizing and building on the knowledge base, iv) addressing urgent climate risks, v) embedding adaptation into policies, laws and regulations, and vi) monitor the progress and effectiveness of adaptation policies (2016).</p> <p>Identified urgent climate effects (Ministerie van I&amp;M): i) more human heat stress with people, ii) more frequent failure of vital and sensitive functions, iii) more crop damage and other agricultural and horticultural damage, iv) a shift in climate zones and damage to flora and fauna, v) decreased health and labour efficiency, and increased costs, and vi) cascading effects between sectors (2016).</p>
Implementation Program NAS 2018-2019 ( <i>Uitvoerings Programma NAS</i> ) (UP NAS)	The UP NAS serves to embed climate adaptation in policies and policy implementations of governments, organisations, and citizens. To do so, the UP NAS initiates a dialogue between governments and relevant stakeholders, to identify objectives, plan action and establish responsibilities.	Identified focus points for 2018-2019 (Ministerie van I&W): i) heat stress and implications for healthcare, infrastructures and built environment, ii) infrastructures and their vulnerability, iii) agriculture, iv) nature, its protection, and nature-based solutions, v) the built environment and vi) cooperation between provincial and regional strategies and visions (2018).
Delta Program 2023 ( <i>Deltaprogramma</i> )	The Delta Program 2023 is the yearly publication that reports on the progress of the last year and the strategic focus points for the new year for the Delta Program. The Delta Program is a cooperation between the national and regional governments that works toward a climate resilient and water robust future in a safe and liveable environment in 2050.	<p>In the Delta Plan for Spatial Adaptation of 2023, the following focus points and opportunities are identified (Ministerie van I&amp;W, Ministerie van LNV, Ministerie van BZK): i) create new buildings and infrastructures climate resilient directly, ii) analyse vulnerabilities at multiple spatial scale levels, iii) municipalities struggle with cumulating spatial challenges and limited capacity, iv) the <i>Impuls</i> regulation stimulates implementation of climate adaptation measures, v) investing in green/blue urban environments contributes to a healthy and climate resilient environment.</p> <p>The Delta Program generally has the following points of focus: i) the climate is changing more rapidly; direct action is urgent, and ii) the extreme weather event of Limburg can occur anywhere; focus more on consequence mitigation (2022).</p>

## Delta program

The Delta Program is a cooperation of the national government with provinces, municipalities, and water boards, that works on flood protection, sufficient freshwater supply and towards a climate proof and water robust environment (Ministerie van I&W, 2022). The Delta Program (DP) 2023 reports on the previous year and the points of focus of 2023. The focus points relevant for climate adaptation are given in Table 4.1. An important outcome of the DP2023 is a sense of urgency, as the climate is changing more rapidly and there is no time left to lose (Ministerie van I&W, Ministerie van LNV, Ministerie van BZK, 2022). Figure 4.1 shows the projection of the increasing challenge of climate change and the response the country has made so far, and what is deemed necessary for 2050. This figure emphasizes the importance to prioritize climate adaptation measures and to pay attention to the long-term objectives.

The DP describes strategy for climate adaptation policy in the Delta Plan for Spatial

Adaptation (*Deltaplan Ruimtelijke Adaptatie*) (DPRA). It has established seven ambitions for a climate resilient and water robust future in 2050, which are given in Figure 4.2. Further details can be found on p.128-133 of the Delta Program 2018 (Ministerie I&W, 2017)

## 4.2 Regional level

### 4.2.1 Roles and responsibilities

The twelve provinces are responsible for translating the national water policy framework to a regional framework and objectives, and they oversee that the municipalities and water authorities adhere to these objectives. Concerning groundwater management, the provinces oversee reaching national water quality and ground water level targets, and they coordinate and monitor the exercising of these objectives regionally, by municipalities and water authorities

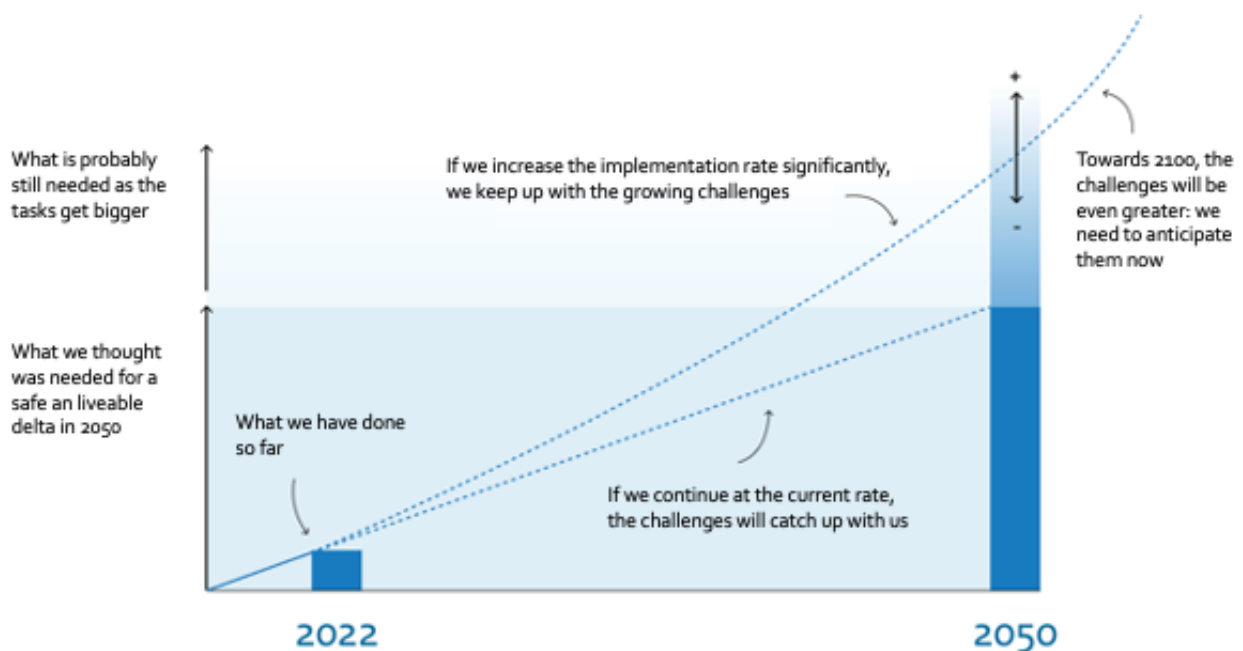

**Figure 4.1:** The projection of the increased challenge faced by the country as a result of the more rapid climate change, and the need to increase efforts to adapt the environment. Adapted from "Nationaal Deltaprogramma 2023 - Hoofdlijnen" by Ministerie van Infrastructuur en Milieu, Ministerie van Landbouw, Natuur en Voedselkwaliteit, Ministerie van Buitenlandse Zaken en Koninkrijksrelaties, 2023, p.4

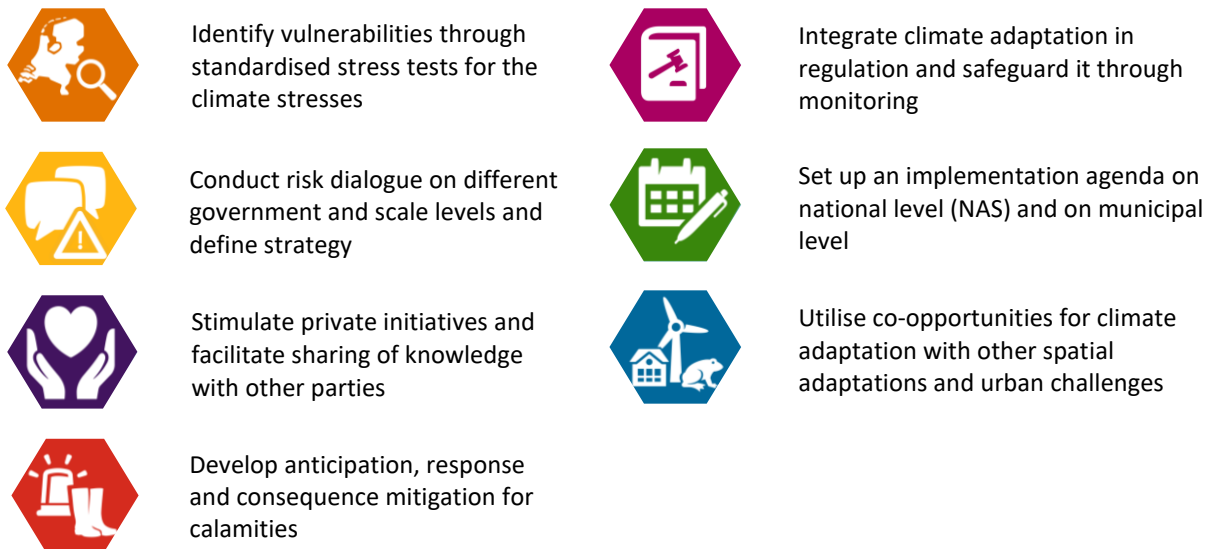

**Figure 4.2:** The seven ambitions for a water robust and climate resilient design of the Netherlands formulated in the Delta Plan for Spatial Adaptation (*Deltaplan Ruimtelijke Adaptatie*) of 2018. Adapted from “Deltaprogramma 2018” by Ministerie van Infrastructuur en Milieu, Ministerie van Economische Zaken, 2017, p.128-133

(Informatiepunt Leefomgeving, n.d.-b). In terms of spatial planning, the provinces create regional spatial policies and regulations and formulate the regional visions for spatial structure (AI, 2022). The provinces are also manager of the provincial roads, that exist throughout the country.

The municipalities have the duty of care over rainwater and groundwater within the municipality and are the owner and manager of the sewer (Mostert, 2022). They are responsible for collecting and processing rainwater in the public space, and also in the private space if the plot owners are not able to do so themselves. The municipality is also in charge of collecting and transporting wastewater. Concerning ground water, the municipality is responsible for measures against groundwater nuisance in public space. In the subsurface of private property, the plot owner is responsible for the groundwater levels (Mostert, 2022).

Furthermore, the municipalities are in charge over the zoning plans throughout the municipality, which are the legally binding instruments for spatial planning, which all parties need to adhere to (Mostert, 2022).

The water boards (*waterschappen*) are the managers of the regional waters (i.e., not the state waters). There are 21 water boards in the

Netherlands and their administration is democratically elected. They are in charge of determining and executing the strategies and measures to realise the regional strategy objectives. In addition, they are responsible for the treatment of the collected wastewater (Rijkswaterstaat, n.d.)

The purification and supply of drinking water is the role of the drinking water companies. There are ten drinking water companies in the Netherlands of which most are owned by municipalities or provinces (Mostert, 2022).

## 4.3 Amsterdam

### 4.3.1 Roles and responsibilities

Amsterdam is a city by the water, the river section *Het IJ* runs between the city center and the Northern part of the city and connects the *IJmeer* on the eastside to the *Noordzeekanaal* on the westside, that ends in the North Sea. The river Amstel runs through the center of Amsterdam and is connected to the river IJ through the city canals. The lake IJmeer is managed by Rijkswaterstaat, the section of the river IJ, the river Amstel as well as other surface waters in the city are managed by the water board Amstel Gooi en Vecht, as further elaborated in the next paragraph.

Amsterdam is located in the province Noord-Holland, as shown in Figure 4.3. Figure 4.4 shows the three water boards of which the administrative regions partly cover Amsterdam: Amstel Gooi en Vecht, Hollands Noorderkwartier and Rijnland. These three water boards each govern a bit of ground within the municipal boundaries of Amsterdam, but the largest part of the city is part of the administrative area of water board Amstel Gooi en Vecht (AGV), as illustrated in Figure 4.5. Water board AGV has outsourced their executive tasks to Waternet, the water cycle company of Amsterdam and surroundings. The water board still holds its administrative function and is still of influence on climate adaptation in Amsterdam, concerning the water system. The water board commissions Waternet, and it also uses its financial resources to provide its citizens with subsidies for green and blue space on their private plots.

On behalf of water board AGV, Waternet takes care of i) wastewater treatment, ii) dike maintenance, iii) groundwater level

management in the polders and natural areas in the region and vi) gathering the water board taxes. In addition to these roles of water board AGV, Waternet is exercising the municipality's role of i) collecting and processing rainwater, ii) managing the groundwater levels, iii) transporting wastewater and managing the sewer to Waternet and iv) the management and maintenance of the canals, bridges and water works in the city (Waterschap Amstel Gooi en Vecht, n.d.). Through these integrated responsibilities, Waternet plays a significant role in climate adaptation planning and design in the built environment of Amsterdam. Mainly through designing the city's drainage system, designing blue spaces in the public built environment, and controlling the groundwater level. Besides these responsibilities, Waternet is also in charge of the purification and supply of drinking water and therefore covers the complete water cycle. This is a unique combination in the Netherlands, different to all other drinking water companies and water boards. The region where Waternet is active is larger than Amsterdam, but only in Amsterdam



Figure 4.3: The twelve provinces of the Netherlands and Amsterdam in the province Noord-Holland



Figure 4.4: The 21 water boards in the Netherlands and the three water boards with administrative area in Amsterdam

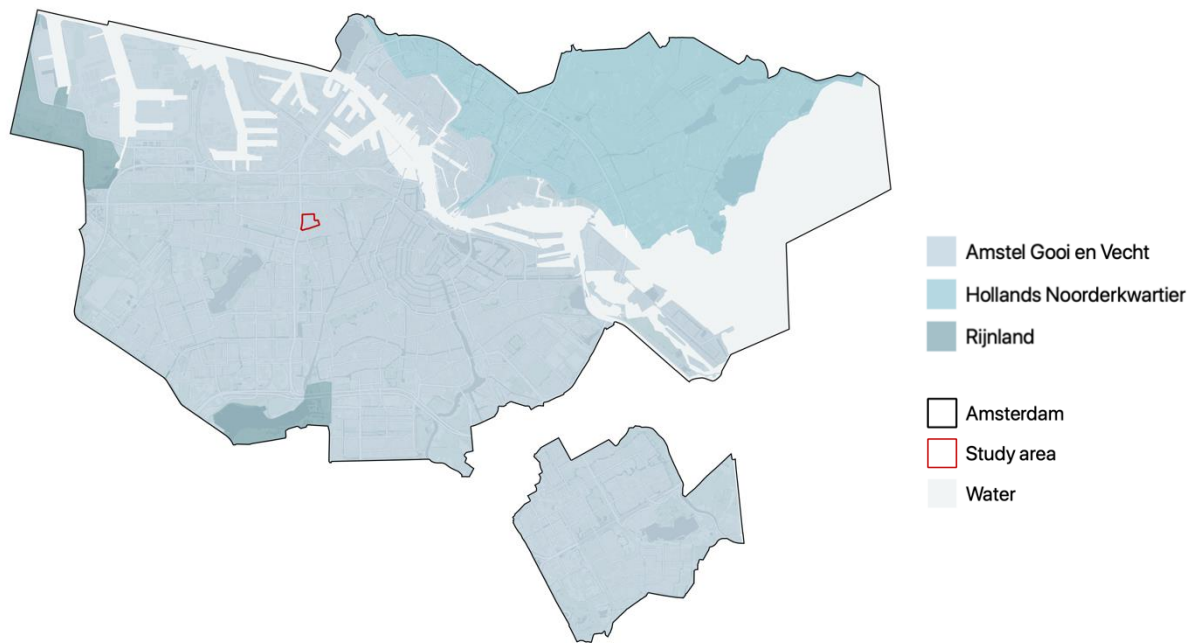

**Figure 4.5:** The administrative areas in Amsterdam of the three water boards and the study area located in Amstel Gooi en Vecht.

Waternet is working in commission of the municipality of Amsterdam.

The municipality of Amsterdam is the central organisation involved in climate adaptation and spatial redesign of the urban environment in Amsterdam. They own the public space and create regulation and laws for residents and owners of private property to stimulate climate adaptation in the private space. Besides the departments Spatial Developments & Sustainability, Infrastructure & Public Space and the Engineering Agency that are naturally involved in the climate adaptive redesign of the public space, the municipality has a thematic program Climate Adaptation, that aims for a climate- and future resilient Amsterdam. In response to the national policy DPRA, the program established the Implementation Agenda, that defines the problem and the current and possible future strategy concerning climate adaptation. This policy piece is further elaborated in Section 4.3.2.

Furthermore, Amsterdam Rainproof is a central organisation involved in climate adaptation in Amsterdam. The organisation is

part of Waternet and started out with a focus on pluvial flooding alone. It facilitates a network between all parties involved in the transition towards a rainwater resilient city. As part of its network approach, it connects private parties such as housing corporations and companies to the issue of pluvial flooding and to the municipality and Waternet. It stimulates knowledge exchange and collaborations between the parties and plays a significant part in putting policy to practice. Currently, Amsterdam Rainproof has broadened its approach to the climate stresses of heat, drought, and fluvial flooding as well, in cooperation with the municipality.

#### **4.3.1.1 Case study: Bosleeuw Midden**

In this Section, the relevant stakeholders for climate adaptive redesign of the case study area Bosleeuw Midden are described. The different roles and spatial domains of the stakeholders are shown in Figure 4.6 and discussed below.

National government: As Bosleeuw Midden is not located near the IJ and possible climate adaptation measures are not hydrologically

linked to the IJ, the water manager Rijkswaterstaat is not relevant. How the regulatory policy instruments of the national government influence the climate adaptive redesign of Bosleeuw Midden is explained in Section 4.3.2.

Province: As the tasks of the province Noord-Holland in the urban built environment in Amsterdam merely concern the provincial roads going into the city and the deeper groundwater and its quality, the province Noord-Holland is not substantially involved in climate adaptive redesign of Bosleeuw Midden, unless measures affect the deeper groundwaters.

Water board: Figure 4.5 also shows that Bosleeuw Midden is located in the administrative area of water board AGV, so that is the governing water board for the area. Its influence and interests are exercised

through Waternet, which is a very relevant and involved stakeholder.

Municipality: Similarly, the municipality of Amsterdam is a very relevant and involved stakeholder, as explained in the previous section.

### 4.3.2 Policies and regulation

A short insight is given into the content of the thematic policies that are central to climate adaptation planning and spatial planning in Amsterdam. It is discussed how they impact spatial adaptations for rainwater resilience and to what extent the climate stress is integrated in it.

#### Implementation Agenda

The Implementation Agenda for climate adaptation (*Uitvoeringsagenda Klimaat-adaptatie*) (UA) is made by the municipality of Amsterdam in response to the national DRPA.

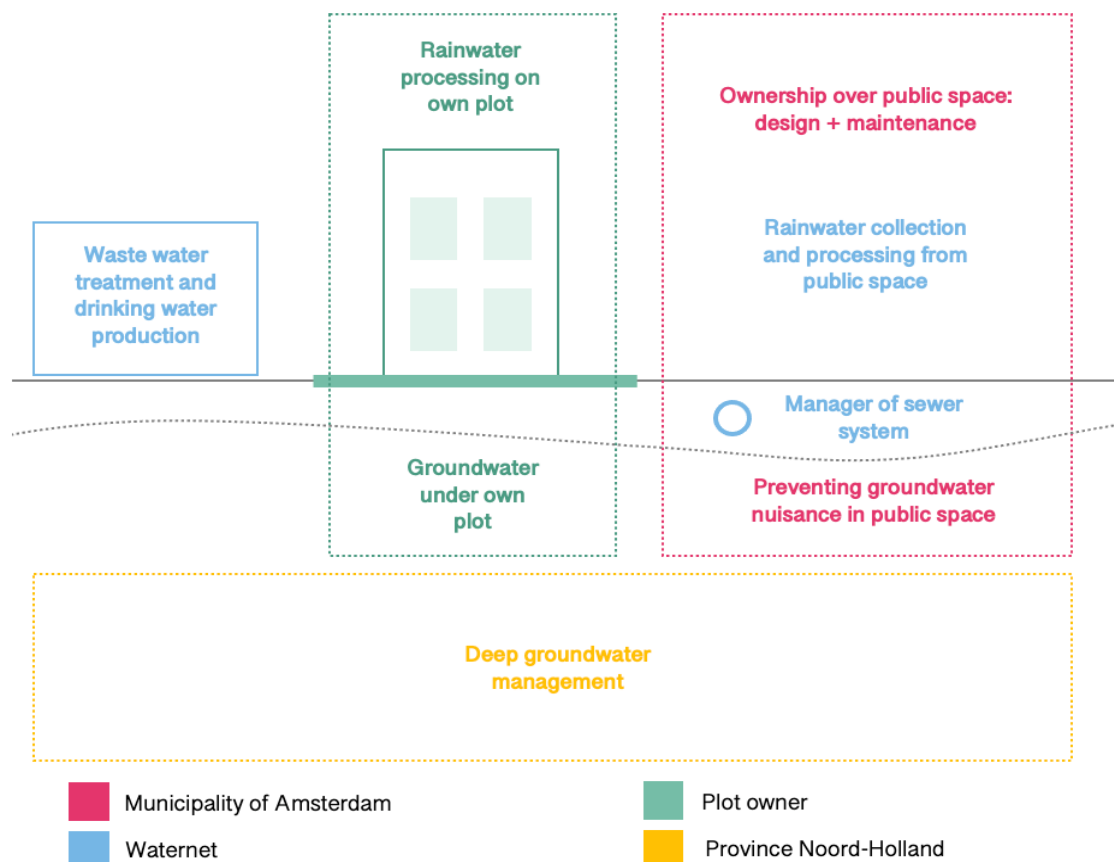

**Figure 4.6:** The different roles and spatial domains of the involved governmental organizations and the plot owner, for the case study Bosleeuw. Adapted from “Pathways for climate adaptive Havenstad” by Liefstink, 2021, p.83.



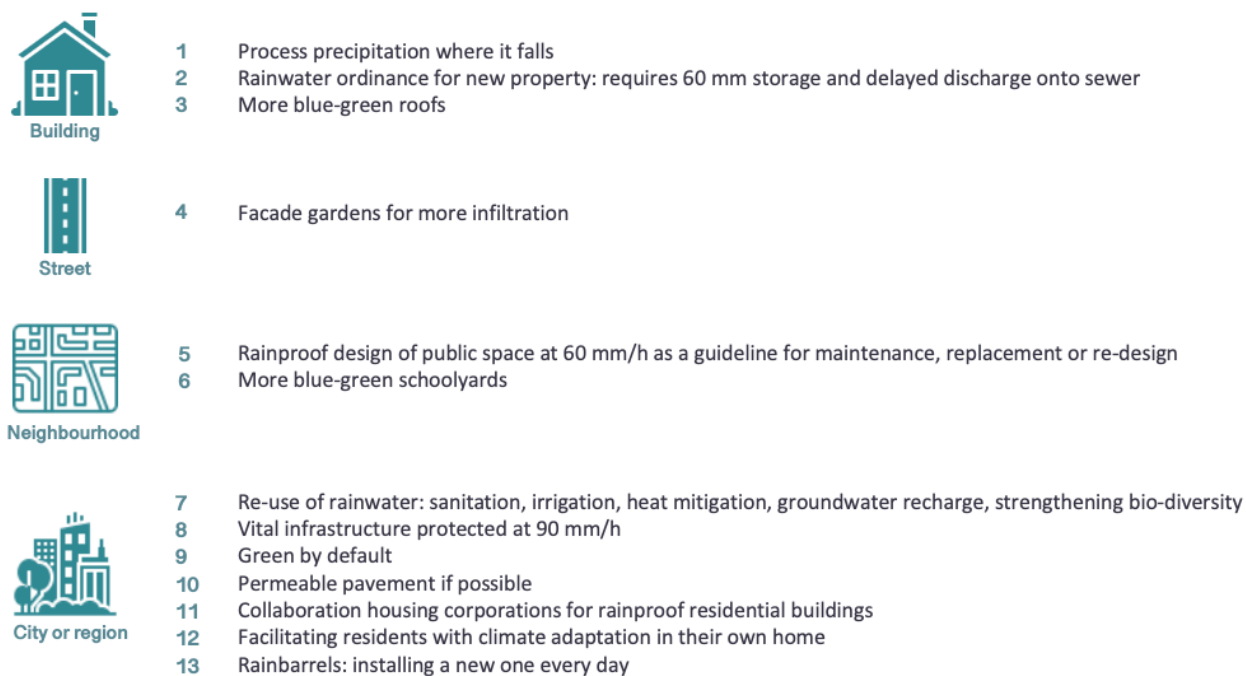

**Figure 4.7:** The new guidelines for preventing pluvial flooding, established in the Implementation Agenda, and categorized by scale at which the issues are targeted. Adapted from “Uitvoeringsagenda Klimaatadaptatie” by Gemeente Amsterdam, 2021, p.95-96.

It presents the challenges of climate stress, gives structure to the approach of the municipality, and identifies new strategy focus points. For the stress of pluvial flooding, two objectives are defined, i) preventing damage and nuisance due to heavy rainfall as much as possible, and ii) utilising rainwater for the liveability of the city (Gemeente Amsterdam, 2021a). For achieving these, thirteen guidelines are identified, and shown in Figure 4.7. This list is not exhaustive, and it is mentioned that the guidelines and different scales are not independent from each other. Nevertheless, the principles most relevant to the design of public space are principles 1, 5, 7, 8, 9 and 10: processing precipitation where it falls, designing a public space that can process 60 mm/h without suffering damage, re-use of rainwater rather than discharging it, creating more green space and realise permeable pavement where possible. It states that rainproof design of the public space is a guiding principle for every spatial adaptation in the public space, and that it should be checked if a new design is able to process 60 mm of rain in an hour without damage caused. The UA does not offer further elaboration on how these

guidelines will be realised or through which policy instruments.

A list of established policy points concerning pluvial flooding is given in the UA and is summarised in Figure 4.8.

This list of policy points reiterates the fact that designing the public (and private) space to be rainproof. It also mentions the objective of creating a rainwater processing capacity of 60 mm/h. Furthermore, it states the principle of processing the rain where it falls: retain it, re-use it or let in infiltrate before opting for draining to process it in a different area.

The list shows the established policy documents that cover these policy points on pluvial flooding.

### 4.3.3 Planning and decision-making process

The planning process for spatial redesign of the public space in Amsterdam is regulated and defined by the ‘Plan- en Besluitvormingsproces Infrastructuur’ (PBI), which is the process for



**Visie Openbare Ruimte 2025 (2017):**

- Creating more green on streets, squares, facades and roofs
- Rainproof is the guiding principle for designing public and private space

**Handboek Rood** for street design (2019):

- Street design should follow the norms for water storage and water discharge capacity
- Rainproof is the guiding principle for every re-design step in public space
- Reference to assessment tools and design instruments (Rainproof factsheets and solution maps)

**GRP 2016-2022:**

- 60 mm with no damage to housing and vital infrastructure
- Process rain where it falls; utilize over discharge
- Plot owner responsible for rainwater processing on own plot
- Robust, flexible and open rainwater processing system > adaptable
- Rainwater processing is an obligation for municipality of effort, not of result
- Preference for separate sewer system
- Excessive groundwater drained onto open water, not RWZI
- Other groundwater management statements

**AGV Keur (2019):**

- Pavement must allow controlled open stormwater discharge
- Pavement and loss of infiltration and storage capacity must be compensated
- Water storage incorporated in the zoning plans

**Puccini method (2019):**

- Rainproof is guiding principle in selecting materials and vegetation in public space

**Rainwater ordinance (2021):**

- New built property must retain 60 mm of rainfall and discharge with delay

**Figure 4.8:** A list of design standards for design of the public space in Amsterdam, that defined in municipal policy documents to increase the resilience for pluvial flooding, as summarized in the Implementation Agenda (*Uitvoeringsagenda*). Adopted from “Uitvoeringsagenda Klimaatadaptatie” by Gemeente Amsterdam, 2021, p.92-94.

planning and decision-making for infrastructure. It regulates all projects in the public space that concern redesign, renewal, or maintenance (Gemeente Amsterdam, 2019), i.e., every spatial adaptation in the existing urban public space. The planning and decision-making process of projects in newly developed areas is governed by a different process: the *Plaberum*, the ‘Plan en Besluitvormingsproces voor Ruimtelijke Maatregelen’.

The PBI describes the process according to which all projects need to be made. It defines the phases a project needs to go through: the initiative, the design principles, the predesign, and the final design and the realisation and maintenance (Gemeente Amsterdam, 2019). It also defines the products that need to be established for the decisions to be made officially. An overview of the project phases, required products and moments of approval are given in Appendix A.

The PBI is written and established by the department *Verkeer en Openbare Ruimte* (Gemeente Amsterdam, 2019), to regulate the process for projects in the public space in preparation of approval. It was made in collaboration with other municipal departments involved in infrastructural projects, but not with Waternet. All projects require approval by the alderman or the city council before they can be executed. The PBI is the agreed upon process that is followed for all projects in the public space, to be granted approval for execution. It is noted in the PBI that it is a guideline rather than a blue-print, and that additional steps should be considered by the project managers (Gemeente Amsterdam, 2019).

As part of the planning and decision-making process, all projects are tested by a committee that checks if the project is in accordance with the policy principles, established by the city council in the coalition agreement. Based on

the outcomes of the test of the committee, the alderman or the city council grants approval. As such, the policy principles of the coalition agreement are enforced through the PBI and these moments of assessment.

In the PBI, updated in 2019, there is very little mention of the climate stresses. Pluvial flooding specifically, is not mentioned at all. The only mention of climate stress is that climate robustness is included in a list of suggested criteria to be looked into as part of the technical management of the project in the predesign phase (Gemeente Amsterdam, 2019, p.50). It is grouped in list with wind load, dewatering, sustainability, geotechnics, unexploded ordnance, trees, and asbestos (Gemeente Amsterdam, 2019). Other mentioned technical aspects cover the groundwater system, subsurface infrastructures, safety measures and requirements, construction calculations, traffic aspects and public space requirements. There is no suggestion on how to assess climate resilience or rainwater robustness, nor a mention of what climate adaptation policies or guidelines exist within the municipality, such as the OPR 2022-2027 or the Solution Maps as design tools. It is noted that professionals working on the infrastructural projects are expected to use other guidelines, but only the HIOR and Puccini are mentioned, which contain little to no mention of pluvial flooding.

Currently, the test committee does not check projects on resilience to pluvial flooding or other climate stresses. Moreover, the alderman and city council grant approval of projects that have not considered climate resilience or pluvial flooding. Which is remarkable because climate resilience is included in the coalition agreement, as discussed in Section 4.3.2.

Notably, there is a difference in detail level between the thematic policies and the requirements in the planning and decision-making process, concerning pluvial flooding. The thematic policy pieces discussed in Section 4.3.2 go into depth to investigate and define strategies to realize the policy principles of the coalition agreement. They far exceed the level

of detail and even the ambition of the coalition agreement. In addition to these policies, there are solution strategies and design instruments that offer even more knowledge on how to deal with the stress of pluvial flooding and the other climate stresses in the public space.

However, the policy points and guidelines in these thematic policy documents are not integrated into the planning and decision-making process. Because following these thematic policy documents is not required nor explicitly suggested by the agreed upon PBI, and because it is not required for approval by the alderman or city council.

The thematic policies such as the OPR 2022-2027 and the Implementation Agenda are made by the involved departments, and, in other words, from within the water and climate adaptation niches. These policies are drafted by the departments and then established by the city council. However, they are not integrated into the work process that is determined in the PBI, and their use is not enforced by the city council.

Without enforcement, the use of the policy documents is achieved through an active campaign letting more and more employees get acquainted with the content over time. As this is time consuming and manpower is not infinite, knowledge tends to stick to its niche. This is a limiting factor to the realization of the climate adaptation objective, considering the fact that employees across multiple departments of the municipality are involved in spatial adaptation projects. Without the guarantee that the guidelines for climate adaptation and the inclusion of an assessment of the climate stresses in the planning process of projects in existing public space, redesigns that are not adapted to climate stress are still being realized.

As a solution to this problem, an assessment of the climate stresses will be developed that is to be obligatory for all projects in the public space. This is announced in the OPR 2022-2027, as mentioned in Section 4.3.2, but has not been developed yet. The objective is to get every project in the public space assessed on its robustness to pluvial flooding, heat stress,

drought stress and fluvial flooding, by employees of the engineering agency of the municipality (IB). The results would then be a requirement in the check by the committee that tests the accordance with the policy principles. If realized, this required assessment would be a guarantee for the actualisation of the established climate adaptation policy and guidelines.

#### **4.4 Findings**

In this chapter, the roles, and responsibilities of the actors with regards to climate adaptation in urban areas were discussed and the relevant policies and regulations were analysed.

The most important actors with regards to the public spatial redesign of urban areas are the municipality of Amsterdam and Waternet. The municipality is the owner of the public space and is responsible for its design and maintenance. Waternet is the manager of the sewer system and is responsible for collecting and processing rainwater from the public space. Together, these organisations work on establishing policies and design principles to create a rainwater resilient public space.

The national and regional scale were also considered, and the analysis showed that national strategies shape climate adaptation policy at municipal level. Following the national

strategy of the Delta Plan, Dutch municipalities were to execute climate stress tests to assess the vulnerabilities of the cities and formulate an implementation agenda for a plan towards a climate resilient future.

For the rest of the analysis and the further steps of the research, the spatial scope remained the municipality of Amsterdam and the case study area Bosleeuw Midden, respectively.

The planning process of spatial redesign of the public space in Amsterdam is described in the *Plan- en Besluitvormingsproces Infrastructuur (PBI)*, that defines the planning- and decision-making process for all spatial adaptations to the infrastructures in the public space. This process is established by the municipality of Amsterdam and regulates all related projects of the municipality.

Guidelines for the design of public space with regards to the stress of pluvial flooding are not part of the PBI but are defined in thematic policy documents that offer detailed knowledge on the stress of pluvial flooding, possible solutions and design principles.

Because following the design principles for more rainwater resilient design in these thematic policies is not yet mandated like following the PBI, they are not embedded in the planning process.

Chapter 5

# Results SQ2

In this chapter, the second sub-research question is answered:

SQ2: How can the adaptive pathways be used for redesigning urban areas to be more resilient to the stress of pluvial flooding?

Adaptive pathways for a rainwater resilient design were developed for the case study area in Bosleeuw. The step-by-step development of the adaptive pathways are shown in Section 5.1. Then, possible improvements to this approach were explored and tested for the case study area. These findings are shown in Section 5.2.

## 5.1 Pathway development

The pathways were developed by applying the first five steps of the Dynamic Adaptive Policy Pathways approach. An explanation of the approach is given in Chapter 1 and further elaboration can be found in the publication by Haasnoot et al. (2013).

To recall, in these steps the following components of the pathways for a considered system are developed:

- An uncertain stressor that is impactful on the system is selected;
- An objective corresponding to this stressor for the system is identified;
- A set of possible measures to attain the objective is developed;
- Sequences of different measures are considered to compare different design alternatives;
- Their corresponding adaptation tipping points and sell-by dates are determined to indicate when the undertaken actions no

longer meet the requirements and additional measures are required.

### 5.1.1 Objective and uncertainty

The first step of the DAPP approach is describing the study area and the objective and uncertainty that are the most relevant to the system (Haasnoot et al., 2013). The description of the study area can be found in Chapter 2.

#### 5.1.1.1 Pluvial flooding objective in Amsterdam

For this case study, the pathways were developed for rainwater resilient redesign of the urban area. The key stressor to the system considered is the expected extreme rainfall intensity. The precipitation intensity is expected to increase, but it is not certain how significantly it will change. The predictions for the precipitation intensity in *mm* for a rainfall event of 60 minutes are given in Table 5.1, for rainfall events with a return period of 100 and 2050 years. The predicted values are given for the lower and upper climate scenarios identified by the KNMI (n.d.), i.e., the best- and worst-case scenario for the increase in precipitation intensity. The two transient scenarios of the climate predictions allow for the explicit consideration of the uncertainty of the system stressor, as each point on the pathways can be viewed within the bandwidth of the values of the lower and the upper scenario.

The objective for making Amsterdam more resilient to the climate stress of pluvial flooding that is held by the municipality and Waternet is that the urban area should be able to process rainwater with sufficient capacity in order to suffer no damage at a rainfall event with a return period of  $T = 100$  years (Waternet,

**Table 5.1:** The climate predictions for increased precipitation intensity in mm for a rainfall event of 60 minutes in the Netherlands, for the rainfall events with a return period  $T$  of 100 years and 250 years. The middle column shows the predictions for the ‘lower’ scenario, the left column for the ‘upper’ scenario. Adapted from “Neerslagstatistiek en -reeksen voor het waterbeheer 2019” by STOWA, 2019, p.15 & p.44

	2014	2030	2050	2085	2030	2050	2085
T = 100 yrs	57.7	60.0	60.0	61.4	62.1	70.0	81.4
T = 250 yrs	74.5	77.4	77.4	79.3	80.2	90.4	105.1
		Best case scenario			Worst case scenario		

2022). It is not defined exactly what is meant with 'suffering no damage', or what it implies for the rate at which the rainwater should be processed. The OPR 2022-2027 does define an order of preference in types of water processing solutions: i) re-use, retention, and infiltration, ii) delayed surface runoff, and iii) drainage through the rainwater sewer system (Waternet, 2022).

Furthermore, the OPR 2022-2027 states that the current objective is a capacity of processing 70 mm/h. This is the precipitation intensity of a rainfall event of 60 minutes with T = 100 years in 2050, predicted for the upper scenario of the climate scenarios (STOWA, 2019). At this level of protection, the target processing capacity in 2085 is 81 mm/h (see Table 5.1).

Together, the increasing precipitation intensity as the uncertain stressor developing over time and the corresponding objective for rainwater processing capacity form the x-axis of the pathway maps that is shown in Section 5.1.6.

#### 5.1.1.2 Rainwater processing capacity

In order to be able to express the effectiveness of spatial measures for climate adaptation, the objective of suffering no damage needed to be translated into a measurable criterium. The capacity to process a rainfall event without suffering damage was in this thesis considered as the capacity to allocate stormwater such that it does no unacceptable damage. The term unacceptable damage was used here, to make a distinction with damage that can be expected to occur in designated retention areas.

It was chosen use storage capacity as the measurable criterium for expressing the capacity to allocate stormwater. The storage capacity is considered as the capacity of storage that is readily available, i.e., fast storage. This means storage available to store water with limited delay, to prevent stormwater accumulation damage. For this case study, it was assumed that the stormwater must be stored within an hour after the start of the rainfall event. This assumption was made because the OPR 2022-2027 does not elaborate this nuance, nor other policies surrounding rainwater resilience.

#### 5.1.1.3 Spatial aspects

In this case, the pathways were developed for spatial redesign, i.e., for a sequence of spatial adaptations. For this application, more focus on the spatial scale of the considered area was required. Specifically for pluvial flooding, the stressor of the system scales with the surface area of the considered area. This is different from the case studies for which the SAPP approach was developed (Liefink, 2021) and applications of the DAPP approach (Haasnoot et al., 2012; Haasnoot et al., 2019) where fluvial flood management systems were considered. In these cases, the considered areas were sections of a shoreline or a dike along a river. The created pathways were focused on these line elements and the interaction between flood barriers and the water level. With the stressor scaling with the considered area, however, it was important to define a meaningful study area, e.g., by catchment or urban typology boundaries, as was done for this case study area (see Section 2.1).

#### 5.1.2 Problem analysis

The second step of the DAPP approach is analysing the problem and comparing the current situation with the identified objective.

The key characteristics of the study area in the current situation, in the context of rainwater resilience, that resulted from the area analysis in Chapter 2 are listed below. The corresponding figures showing the results can be found in Section 2.2.

- i. Pluvial flooding: three areas were identified as pluvial flooding hotspots, with severe expected flooding with a flood depth of 25-30 cm after a rainfall event of 120 mm in one hour. Throughout the rest of the area, 0-15 cm is expected (see Figure 2.5).
- ii. Groundwater level: in around a third of the area is infiltration is impossible, because of high groundwater levels of  $\pm 0.80-0.90$  meters below surface level (see Figure 2.5). Infiltration is only possible in the north-western half of the area, that makes up around 40% of the area.
- iii. Buildings: almost all buildings in the area are four-storey dwellings, with the

exception of the shopping area in the south-western corner of the study area and four sections of terraced houses. All four-storey dwellings and the buildings in the shopping areas have flat roofs that are not yet used for green or blue-green infrastructures. Furthermore, 73% of the dwelling is owned by the housing corporation Stadsgenoot (see Figure 2.4). Lastly, all buildings date from 1940 to 1950.

- iv. Public space: almost 90% of the public space is paved, including 8% of parking space in front of the buildings. There is no open water in the public space and around 10% of is green space (see Figure 2.3).
- v. Private space: almost all private yards are green spaces, and some open water can be found in the collective yards of the dwellings in the northern half of the area. The private green spaces make up for 18% of the total area.
- vi. Solution Map: the Solution Map, shown in Figure 2.2, identifies nine designated water retention areas. These area in the public space, at the location of existing green structures, recreational areas, and an unused space under the highway.

### 5.1.3 Identify measures

The third step of the DAPP approach is the selection of a set of measures. The selected measures are stated below.

- i. (Blue-)green roofs: large amount of unused flat roof surface showed a great potential for water retention on roofs. It was chosen to include both green roofs and blue-green roofs in the measure set. Because the buildings date from 1940 to 1950, it is very likely that a roof renovation is required to increase the load bearing capacity sufficient for blue-green roofs (Solcerova, 2021)
- ii. Permeable pavement: because of the amount of paved surface in the area it was chosen to select the placement of permeable pavement as a measure.
- iii. Water retention areas: the Solution Map illustrated the potential for water retention in the public space. It was chosen to include the designated water retention areas in the measure set.

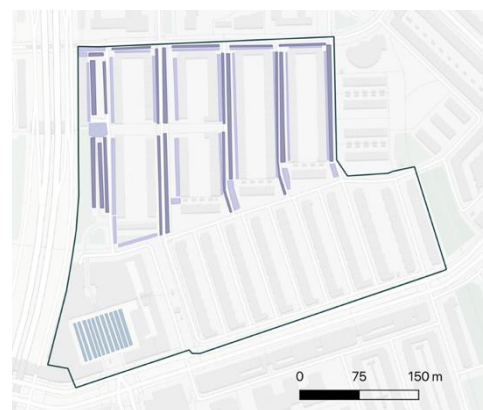
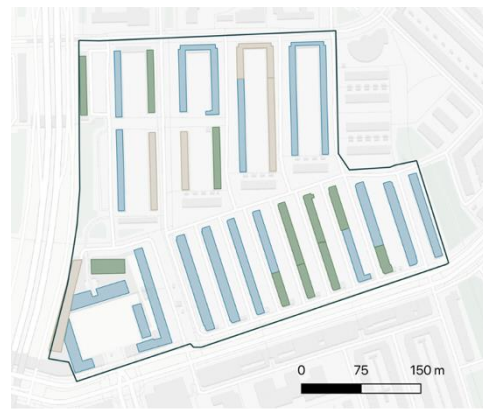

Figure 5.1a-c: The possible locations for the set of measures included in the pathways for the redesign of the study area. Figure 5.1-a shows the use of roof space, 5.1-b shows the plots for water retention areas, and 5.1-c shows the placement of permeable pavement.

Figure 5.1 shows the potential placements of the selected measures. Figure 5.1a shows a design alternative for the realisation of green roofs and blue-green roofs. For this alternative, a random but plausible distribution of (blue)green roofs was chosen. Blue-green roofs on 50% of the flat roof space and green roofs on 15% of the flat roof space in the upper region, where infiltration is possible. In the lower region, 75% of the flat roof space was used for blue-green roofs and 25% of the space for green roofs. In addition to this distribution, the alternative for 100% of the space for blue-green roofs and 0% of the space for either blue-green or green roofs were considered. Figure 5.1b shows the designated areas for water retention, as indicated by the Solution Map. The three areas outside of the study area are connected to the area boundaries. It was assumed that 80% of the potential storage capacity of these designated areas is available for stormwater from inside the study area, as the Solution Map indicates that the inflow from these areas mainly comes from within the study area. For the five designated water

retention areas in the upper region of the study area, infiltration is also possible.

Finally, Figure 5.1c shows the potential placements of permeable pavement. Naturally, all potential placements were selected in the upper region, where infiltration is possible. Three distinct placement types were created: parking places in the streets, the sidewalks, and the parking space within the shopping area.

In Table 5.2, the possible placements of the measures and the current use of the space are listed. These uses were classified as low value uses and high value uses. As Table 5.2 shows, high value use was appointed to the spaces that are actively used or visited by residents: parking space, sidewalks, squares, playgrounds, and parks.

**Table 5.2:** The different locations of the applications of the measures, how they are currently used and a classification of the use value of the locations, differentiating between high value use and low value use.

Measure	Application of measure	Public or private	Use	Use value
<b>Blue-green roofs</b>	-	Private	No use of roof space for water retention or vegetation. Possible use for solar panels.	Low
<b>Green roofs</b>	-	Private	No use of roof space for water retention or vegetation. Possible use for solar panels.	Low
<b>Permeable pavement</b>	Parking spots	Public	Car parking	High
	Pavement	Public	Sidewalk	High
	Parking at the shopping centre	Public	Car parking	High
<b>Water retention areas</b>	I1	Public	Green space and open square in between residential buildings	High
	I2	Public	Playground in between residential buildings	High
	I3	Public	Green space in front of residential building	Low
	I4	Public	Green space in front of residential building	Low
	I5	Public	Green space in front of residential building	Low
	I6	Public	Open square with green space and facilities	High
	O1	Public	No use: empty area under highway	Low
	O2	Public	Park, open square, public soccer field	High
O3	Public	Park	High	



### 5.1.4 Effectiveness of measures

Next in the DAPP approach is the calculation of the effectiveness of the measures. The model presented in Section 3.2.2 was used to calculate the storage capacity of the study area in the current situation and the potential storage capacities of the measures.

The estimated storage capacity of the study area in the current situation is shown in the left diagram in Figure 5.2. The study area has the capacity to store 37 mm of rainfall. The diagram shows that the sewer system constitutes almost half of the available storage currently, and the volume that infiltrates through the green surfaces contributes a significant share.

The right diagram shows the potential storage capacity of the selection of measures, as given in the design option in Figures 5.2a-c. The total storage capacity that can be created by the selected measures is 9000 m<sup>3</sup>, which could increase the current capacity with almost

150%, creating the capacity to store an additional 62 mm of rainfall.

Six combinations of measures that create sufficient potential storage capacity to attain the objective were considered for the pathways. These six combinations were selected from a range of different generated combinations of measures, that are illustrated in Figure B.1 Appendix B.

For the six selected combinations, the resulting total storage capacity of the area for these combinations is shown in Figure 5.3. These combinations were selected because they represent the variety of the outcomes, i.e., they include the lower and upper boundary and four unique values in between. The total values for alternatives S1 to S6 range from ±12300 to ±15550 m<sup>3</sup> and surpass the ±11900 m<sup>3</sup> of required storage capacity to store the potential 81 mm of rainfall that is predicted in 2085 in the worst-case scenario (see Section 5.1.1). This corresponds to the range from ±103% and ±130% of the objective in 2085.

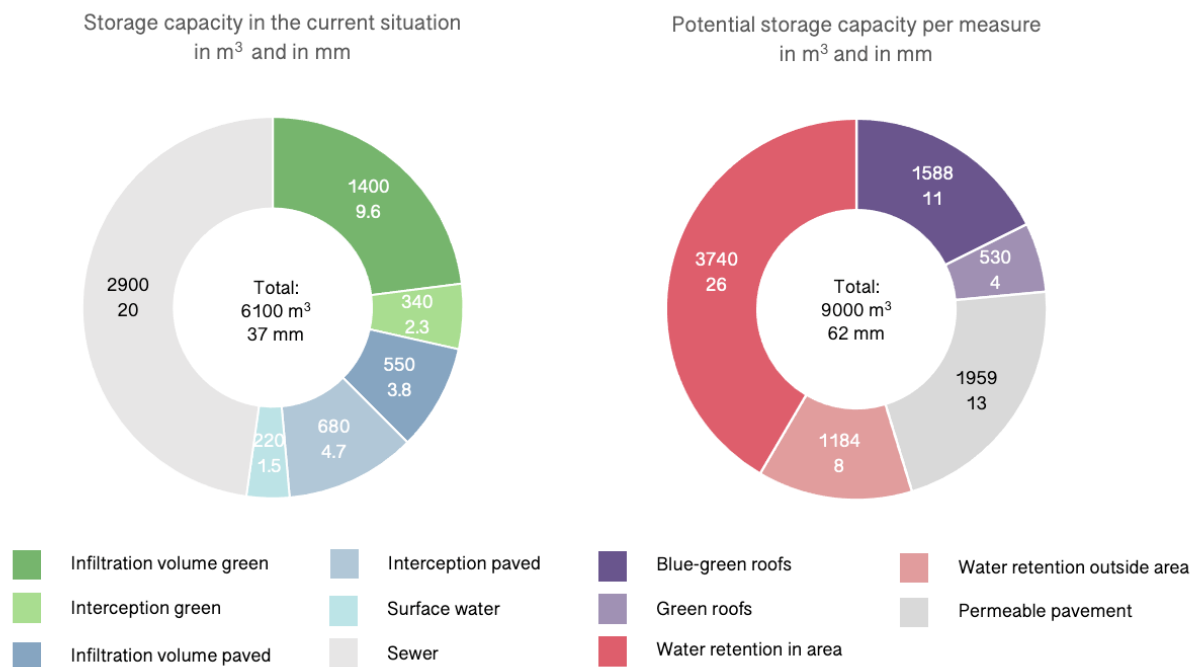

**Figure 5.2:** The storage capacity in the study area of the current situation (left) and the potential storage capacity per selected measure (right) in m<sup>3</sup> storage and in mm of rain. The upper value indicates the storage capacity in m<sup>3</sup>, and the lower value indicates how much mm of rainfall in the area that capacity corresponds to. The storage capacity in the current situation is divided into the elements that contribute to it: storage in the subsurface via infiltration through green and paved surfaces, interception on green and paved surface, storage on surface water and storage in the sewer system.

As Figure 5.3 shows, the water retention areas are the largest contributor of potential storage capacity in all alternatives, apart from alternative S2.

### 5.1.5 Adaptive pathways

A set of pathways developed for alternatives S1 to S6 are illustrated in pathway map I, that is shown in Figure 5.4. The map shows the set of measures on the y-axis. The effectivity of the (combinations of) actions in m<sup>3</sup> storage capacity can be read from the x-axis. Underneath the x-axis, the transient climate scenarios indicate the expected timeline for the increasing precipitation intensity. Together, these horizontal axes represent the objective set for the system: sufficient rainwater storage capacity to sustain a rainfall event with a return period of 100 years.

The pathways show the adaptation tipping points (ATP) for every combination of actions. These ATPs indicate the moment when the

effect of the taken action no longer meets the requirements. The corresponding value on the x-axis shows when this moment occurs in terms of the increased precipitation intensity and storage capacity. The sell-by date, indicating the moment in time where the ATP occurs, can be read from the climate scenarios. Lastly, the decision nodes mark the moment ahead of the ATPs where additional action must be undertaken to attain the objective.

The contributions of each measure per pathway is shown in the complementary illustration in Figure B.3. in Appendix B.

The order of the actions in the sequences was chosen under these considerations:

- i) a preference for measures located in the public space (see Table 5.2)
- ii) preference for measures in locations with use value (see Table 5.2)

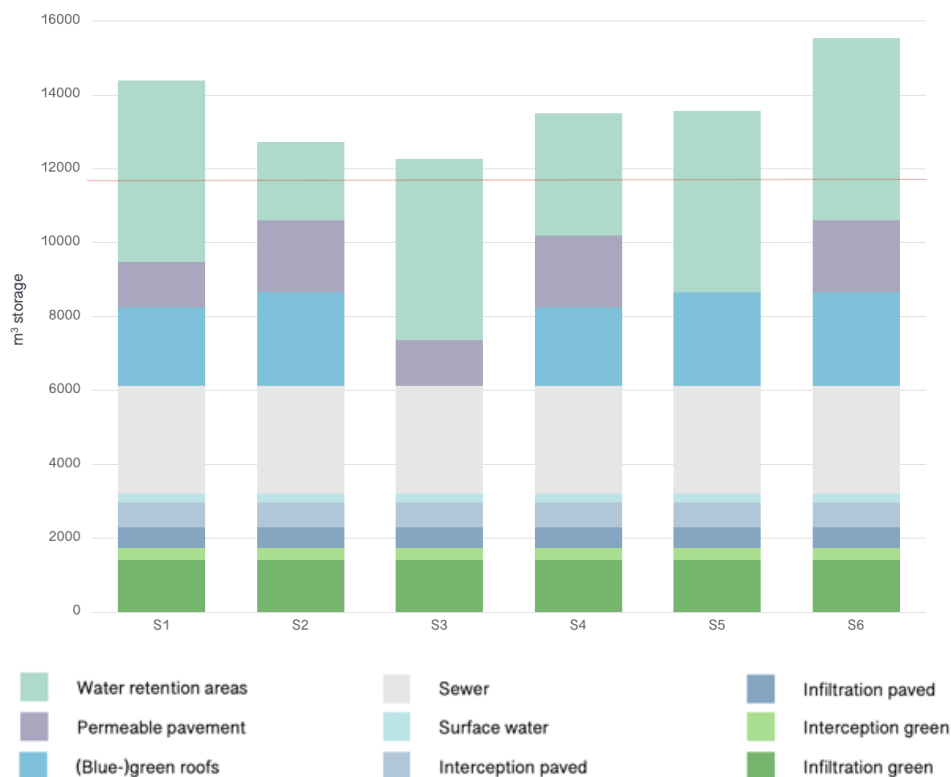

**Figure 5.3:** The potential storage capacity in m<sup>3</sup> for six selected alternatives S1-S6: the contributing elements that exist in the current situation and the contribution per measure type (water retention areas, permeable pavement and (blue-)green roofs).

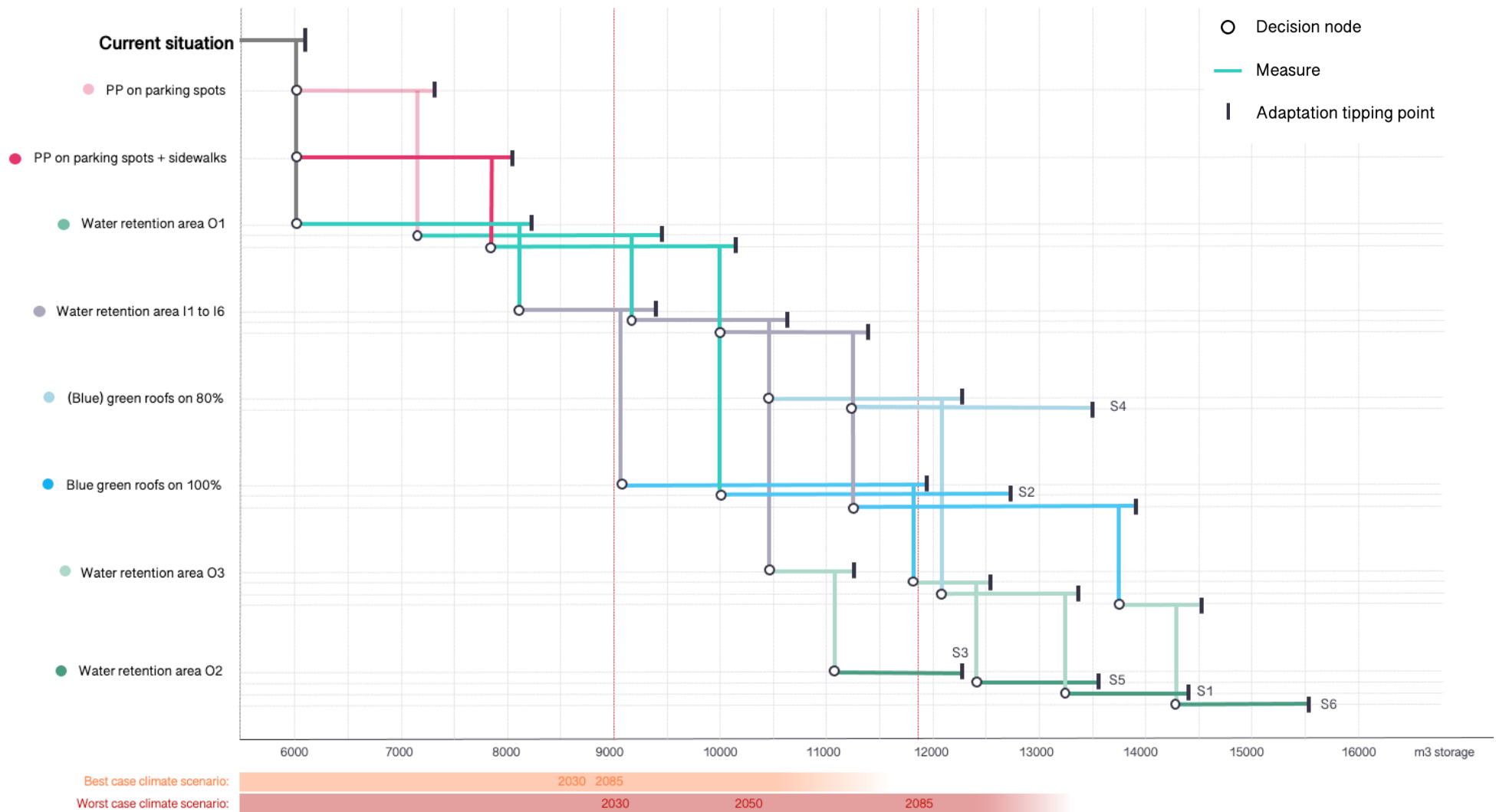

**Figure 5.4:** Pathway map showing the pathways for alternatives S1-S6 for the rainwater resilient redesign for the case study in Bosleeuw. The possible measures are plotted on the y-axis, the resulting storage in m<sup>3</sup> is plotted on the x-axis. Beneath the x-axis, the corresponding moments in time according to the climate projections is illustrated. The year 2085 for the best-case and worst-case scenario is indicated with a dotted red line.

For these pathways, the realisation of blue-green and green roofs on 80% of the rooftops was seen as a single action, rather than two separate ones, for simplification of the figure.

### 5.1.6 Findings

From a planning perspective, the pathways are not realistic, i.e., not indicative of some implicit complexities with regards to the planning and realisation of the pathways.

Firstly, the pathways do not contain information about the time duration between a decision node and ATP (, i.e., between the ATP of the previous pathway section and the decision node of the pathways section that follows). The distance between the illustrated decision nodes and ATPs is arbitrary and does not indicate a duration of time. Thus, this set up of the pathways does not indicate to decision-makers when in time a decision should be made about taking additional action, in order to avoid reaching an adaptation tipping point.

Secondly, the pathways do not consider the implementation time of actions. It is possible that the realisation of the actions is not done in time before its sell-by date. Considering the fact that the actions in the measure set represent very significant spatial adaptations, this can lead to the infeasibility of realising the pathways whilst keeping up with the developing stressor (i.e., avoid reaching a tipping point).

An important consideration to emphasize is that the pathways following to the DAPP approach explicitly take into account the uncertainty of the future. They do so by reviewing the timeline in two transient climate scenarios, which creates a range between the best- and worst-case progression of the stressor, and by expressing the decision moments in terms of the development of the stressor rather than time. As such, there is an abstract perspective on time.

For this case-study, however, the significant size of the planned measures with limited time available results in that not incorporating

temporal details in these pathways limits the perceived feasibility of these pathways.

Thirdly, there is a large time lag between the current situation and the aimed situation according to the climate projections and the policy objective. The plotted climate scenarios underneath the x-axis indicate a target value of  $\pm 8800$  and  $\pm 9100$  m<sup>3</sup> by 2030 for the best-case and worst-case scenarios respectively. The storage capacity of the current situation in 2023 of  $\pm 6100$  m<sup>3</sup> is significantly less. Consequently, the sell-by date of the combinations with a resulting storage capacity of below 9100 m<sup>3</sup> (worst-case) cannot be defined or indicated with the timeline underneath the x-axis. As a result, the ATPs for these points along the pathways are reduced to merely expressing the effectiveness of the undertaken action and are not indicative of a moment in time. Nor are the decision nodes in this section of the pathways. In theory, it shows that this set-up of the pathways does not provide information about the planning over time of the decision-making and implementation of measures during this 'catch up' period. In practice, this means that the developing objective has to be caught up with before the storage capacity can grow along with the developing rainfall intensities.

Furthermore, the pathways are split into multiple lines for one measure more frequently than the presented examples in Chapter 1. As discussed in Section 1.2, an additional pathway line in the same colour is created if the different combinations of previous actions result in different ATPs. This concept was introduced as a part of the DAPP approach but only as a solution to exceptional conditions, i.e., it occurred once in the exemplary map by Haasnoot et al., (2012; 2013) and not at all in the pathways by Liefstink (2021). In this case, regarding pluvial flooding and storage capacity at a neighbourhood scale, the resulting storage capacity of multiple measures is the sum of those measures. This means that every unique sequence of measures has a different resulting effect, and that the ATPs that indicate the resulting effect of a sequence of measures, is different for every different combination. As a consequence, there were multiple lines

indicating the implementation of the measures for all instances with multiple optional pathways prior to that moment. Which is the case for all measures but the first two; from the water retention area O1 onward. Notably, there was a significant difference in how the pathways take form for the stressor pluvial flooding at this level of detail, in comparison to the pathways made by Haasnoot et al., (2012; 2013) and Liefink (2021).

The splitting of the pathways made the illustration more complex because the split lines and ATPs include more information into the map. Therefore, it was not possible to include as many solutions as the maps by Haasnoot et al., (2012; 2013). The explored solution space was reduced to a number of pathways prior, which were then included in the map. This reduction to a comprehensible set of pathways was possible because a predefined order of actions was identified, reducing the number of possible pathways significantly.

Consequently, this set-up of the pathways for rainwater resilience cannot encompass as

many open future choices as pathways following to the DAPP approach introduced by Haasnoot et. al (2012;2013) or the SAPP approach by Liefink (2021). In other words, the use of the pathways following to the DAPP approach for rainwater resilience in this specific case is limited in its functionality of presenting pathways with a range of flexible open choices in the future.

Nevertheless, the resulting set of visualised pathways is indicative for the range of the solution space, i.e., the very distinctive available options are illustrated in the map and a set of open choices is included. Thus, a set of available choices that a decisionmaker is faced with is demonstrated, even though the map does not contain all theoretically possible solutions.

And lastly, the attainability of the objective is effectively demonstrated by the pathways. The effect of the different alternative solutions is shown, and the pathways give insight into how much storage can be realised with each measure.

## 5.2 Modified set-up of pathways

In this section, modifications to the set-up of the pathways are elaborated, tested, and analysed. In Section 5.2.1 the modifications are discussed. In Section 5.2.2, the modified pathway set-up is experimented with under a set of different conditions and circumstances. Lastly, the concluding findings are discussed in Section 5.2.3.

### 5.2.1 Modified pathway set-up

In response to the findings on the pathways in the previous section, a set of modifications was made to the set-up of the pathways to explore and develop additional functionalities of the pathways approach. The pathways were deconstructed and reconstructed into a new modified set-up to add more information to the map and visualize the feasibility of the pathways and their implementation process and implementation rate. The modified pathway map is shown in Figure 5.6. A legend showing the elements of the new pathway sections is shown in Figure 5.5. The pathway map includes pathways for one design alternative: the set of actions of alternative S1. Also, the blue-green roofs and green roofs are considered separately in the modified pathway set-up.

Different to the previous map, this map shows the implementation steps of the actions through incrementing percentages of realised measures on the y-axis. Also, the pathways indicate the duration of the implementation of

the measures, consisting of a decision-making and execution process. Furthermore, the adaptation tipping points in the pathway map are defined for the combination of all measures taken at that point, leading to a shared ATP for multiple pathway sections. And lastly, a new timeline is included in the pathways map to bridge the gap between the current situation and the target values according to the climate projections. These modifications are further elaborated and motivated in Section 5.2.1.1-5.2.1.5. The insights gained from the new pathways for the case study area are given in Section 5.2.1.6.

#### 5.2.1.1 Implementation time

The first modification is the addition of the implementation time as a feature that can be interpreted from the pathways. One of the observations made in of the first pathway map (see Figure 5.4) was that it does not contain information about the implementation time of the measures. Therefore, that version of the pathways does not indicate the exact moment in time when decisions must be made. This was included in the new pathways. The implementation time was divided into the time required for the decision-making process and the execution of a measure, which are both indicated by the dotted lines in the pathways. The decision node was split in two: both the moment of the start of the decision-making process and the start of the execution process of a measure were indicated with a node.

- Moment of decisionmaking process of each measure
- ..... Time needed for decisionmaking process
- Measure
- Moment of execution of measure
- ..... Time needed to execute measure
- | Adaptation tipping point



Figure 5.5: An illustration of a pathway section that indicates the implementation time of an action, including the time required for the decision-making process and the execution process.

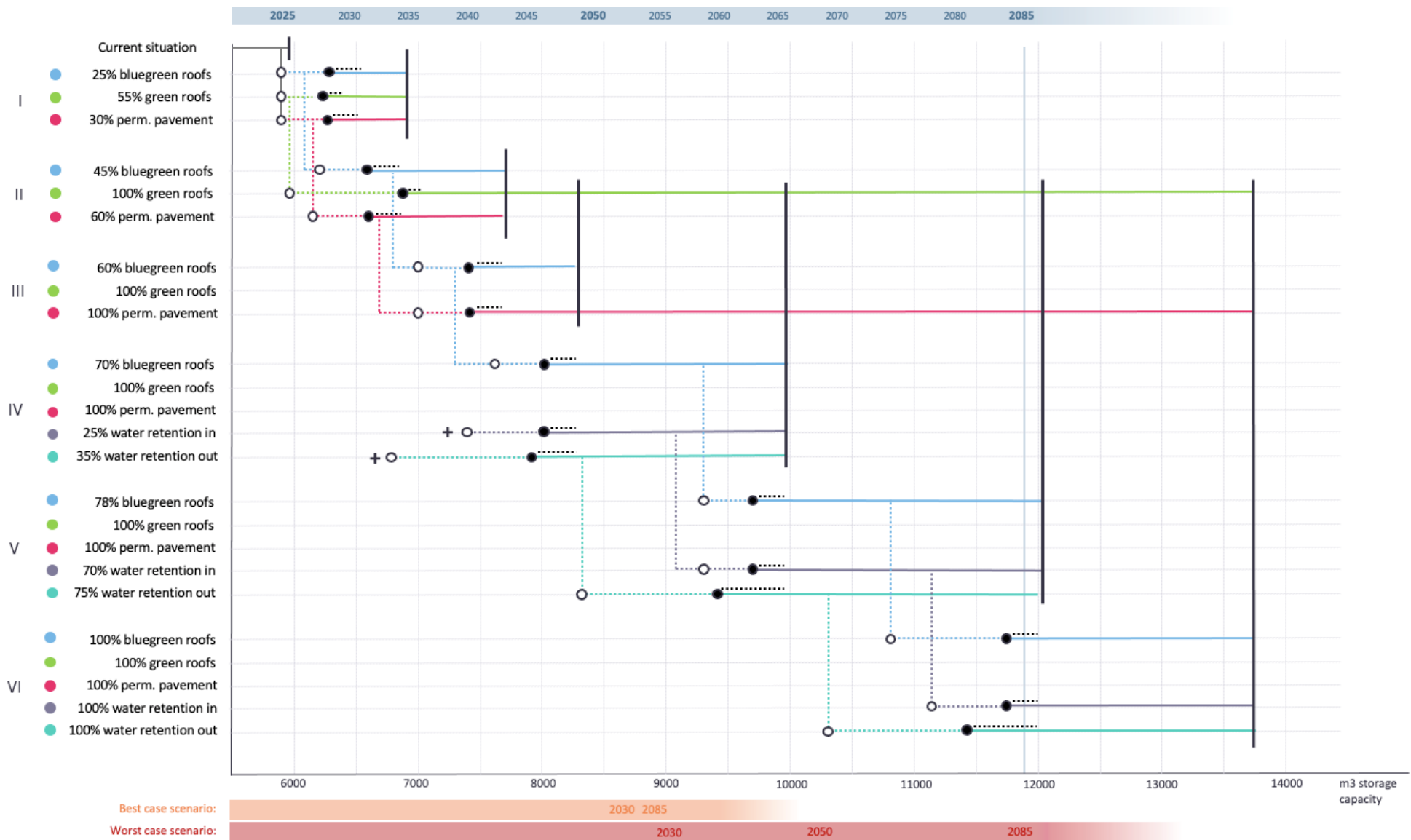

**Figure 5.6:** Pathway map in the modified pathway set-up illustrating pathways for the implementation of the design alternative S1 for the rainwater resilient redesign for the case study in Bosleeuw. The progression (%) of the realisation of the measures is plotted on the y-axis, the resulting storage in m<sup>3</sup> is plotted on the x-axis. Beneath the x-axis, the corresponding moments in time according to the climate predictions is illustrated. The year 2085 for the worst-case scenario is indicated with the blue line. At the top of the map, an additional timeline is plotted that represents a linear progression of time between the storage capacity of the current situation and the target value of 2085, in the worst-case scenario.

The inclusion of the decision-making and execution process allowed for the development of the pathways under the following condition: the timing of the actions is determined by the principle that the execution time of the new actions finishes before the ATP of the prior actions is finished.

**5.2.1.3 Incremental steps**

To make the pathways more insightful for the planning of the actions over time, the realisation of the measures was divided over multiple implementation steps that each represents the incrementing fraction of the measure that is realised. The different actions (blue-green roofs, green roofs, permeable pavement, and water retention areas inside and outside of the area) are still shown on the y-axis but are expressed in the progression (%) of the realisation of the measure. For the blue-green roofs, the action in alternative S1 is the realisation of blue-green roofs on the designated 80% of the available rooftop space (see Figure 5.4). In the new pathway map in Figure 5.5, this action is expressed in six different implementation steps that represent the realisation of 25%, 45%, 60%, 70%, 78% and 100% of the designated rooftops for blue-green roofs. The number of steps considered differs per measure but was kept at a of six to prevent the map from becoming too complex.

Appendix B.4 shows the implementation steps for each measure, indicating which designated location is targeted in which step. Figure 5.7 shows the resulting potential storage realized per implementation step for each measure. The figures clearly show the significance of the contribution of storage capacity per measure and that the water retention areas outside of the case study area are the largest contributor, as we have seen already before.

The order of the implementation of the actions was chosen arbitrarily.

**5.2.1.4 Duration of implementation process**

To estimate the duration of the decision-making and execution process of the measures, a set of characteristics was identified per measure. Table 5.3 shows the complexity of the governance structure of the buildings and spaces, based on their ownership, and the resulting estimates for the durations of the implementation of the measures.

In Appendix B.5, the different owner types for the different rooftop spaces are shown. The complexity of the governance structure of the buildings was derived from the notion that a blue-green roof is only feasible for a rooftop

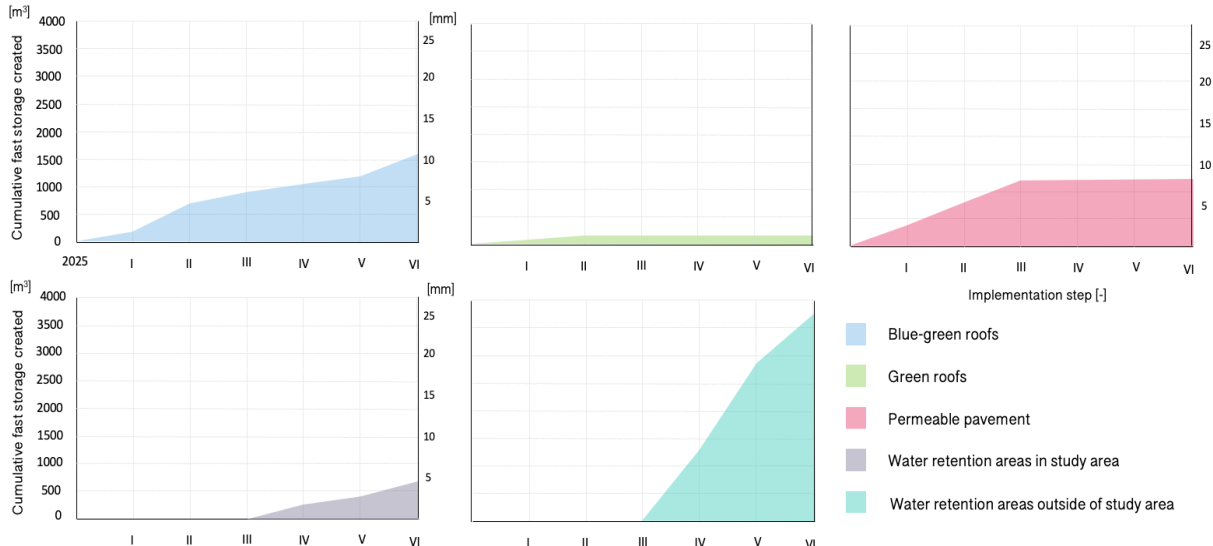

Figure 5.7: The cumulative fast storage in m<sup>3</sup> and in mm created per implementation step for each measure.



**Table 5.3:** Characteristics of the locations of the measures per implementation step and the duration of the decision-making process and the execution process. The implementation steps are indicated with the numbers I-VI. The governance structure of the buildings and spaces is determined based on the ownership of the locations. The last column describes how the governance complexity determined the estimation of the duration of the decision-making and execution process.

Measure	Implementation step	Owner of building/manager of space	Governance complexity	Duration of decision-making process	Duration of execution process	Motivation
<b>Blue-green roofs</b>	BG I	Companies	Low	3 years	2 years (8 years in series)	Single owner for a large building row or block
	BG II	Housing corporations, residents, project developers	Low	3 years	2 years (8 years in series)	Single owner for a large building row or block
	BG III	Housing corporations	Low	3 years	2 years	Single owner for a large building row or block
	BG IV	Housing corporations, project developers	Low	3 years	2 years	Single owner for a large building row or block
	BG V	Housing corporations	Low	3 years	2 years	Single owner for a large building row or block
	BG VI	Housing corporations, residents	High	8 years	2 years (8 years in series)	Collaborative use of rooftop space is required because rooftops are owned by individual homeowners
<b>Green roofs</b>	G I	Housing corporations, project developers, companies	Low	2 years	1 year	Single owner for a large building row or block
	G II	Housing corporations, residents	High	8 years	1 year	Collaborative use of rooftop space is required because rooftops are owned by individual homeowners
<b>Permeable pavement</b>	PP I	Municipality	Low	3 years	2 years (8 years in series)	All permeable pavement spots are viewed similarly
	PP II	Municipality	Low	3 years	2 years (8 years in series)	All permeable pavement spots are viewed similarly
	PP III	Municipality	Low	3 years	2 years	All permeable pavement spots are viewed similarly
<b>Water retention areas inside the area</b>	I IV	Municipality	High	5 years	2 years	High use value for residents and in between buildings of housing corporations (I1, I2)
	I V	Municipality	Low	3 years	2 years	Unused space (I3, I4, I5)
	I VI	Municipality, companies	High	5 years	2 years	High value use for residents and location of two small catering facilities (I6)
<b>Water retention areas outside of the area</b>	O IV	Municipality	High	10 years	3 years	Empty space with low value use, but would require an impactful change of zoning plan (O1)
	O V	Municipality	High	10 years	5 years	Park, open square and public soccer field with high value. Higher duration for execution because of the large surface (O2)
	O VI	Municipality	High	10 years	5 years	Park with high value use. Higher duration for execution because of the large surface (O3)

with a surface area of 200 m<sup>2</sup> or more (Solceroca, 2021). If a building block with a rooftop of >200 m<sup>2</sup> has a single owner, e.g., a housing corporation, a lower level of governance complexity is expected during the decision-making process. If a building block consists of individually owned rooftops, a collaboration of homeowners is required for the realisation of a blue-green roof, for which a higher level of complexity is expected.

The results in Table 5.3 show that for the buildings with individual homeowners and separate ownership of the rooftop space, the realisation of a collaborative rooftop is expected to be very time consuming. Because there are multiple private actors involved as homeowners, it is likely that stimulation such as targeting homeowners for collaborations or subsidies from Gemeente Amsterdam and Waternet are needed to convince the people to take action at this scale. Therefore, it is important to recognize the lengthy decision-making process that is expected before the measure is realised.

For the other measures, a high level of complexity for the governance structure is expected for the areas that have a high use value, that contain parts that are owned by other parties or for which a zoning plan change is required.

It can be seen that the water retention areas also have a long estimated decision-making process. For the water retention areas inside the study area, I1, I2 and I6, the decision-making process was expected to be long (5 years) because the locations have a high use value and have private actors involved in the space: for I2, the area is directly adjacent to residential buildings blocks of a housing corporation on each side, and in I6 there are two retailers situated. This increased the perceived level of complexity of the locations and thus the expected duration for decision-making.

For the water retention areas outside of the study area, the estimated decision-making process is also long (10 years). This was expected due to the large surface area of these

locations. A large chunk of the public space is impacted by an intensive change, affecting a lot of residents in the area because of the high use value (O2, O3) and the costs are likely to be high. In the case of O1, an area with a low use value, the high level of complexity was perceived because a change in zoning plan likely is required for the realisation of the water retention area.

The take-away message from listing the expected level of complexity and the expected duration of the decision-making process is that the implementation of some measures clearly requires a timely start of the lengthy decision-making process, which is important when planning actions over time.

For the estimation of the execution period, the required time for the (blue-)green roofs was estimated with expert input and the required time for the measures in the public space was estimated by data on the planned execution of similar projects in Amsterdam (Gemeente Amsterdam, n.d.-b).

The durations of the execution process were estimated under the assumption that the realisation of multiple placements of a measure is done simultaneously. In other words, the considered execution time for multiple strokes of permeable pavement, for example, is the time that is required for the realisation of a single stroke of permeable pavement.

It is important to note that if this is not the case, and the multiple locations of permeable pavement are realised in series rather than parallel, the execution time can significantly increase. An estimation for these 'in series' execution durations are mentioned between brackets in Table 5.3, for the actions where this is the case ((blue-)green roofs and permeable pavement), because multiple placements of these measures are considered in one step.

Moreover, this set-up of the pathway map with the emphasis on implementation time fails to convey other important characteristics for planning and policymaking, such as the level of

complexity and intensity of implementing the measures or the costs associated with it. These considerations were not taken into account for this case-study.

#### 5.2.1.5 Shared adaptation tipping points

The modified pathway set-up in Figure 5.6 show different adaptation tipping points (ATPs) than the first set of pathways in Figure 5.4. The new ATPs are shared by the combination of all measures grouped in the implementation step. This concept was introduced by Liefertink (2022) in a short exploration of how ATPs could be expressed for the climate stressor pluvial flooding. In the modified pathway set-up, the shared

ATPs allow for the incremental implementation steps, i.e., the incrementing realisation of a measure through multiple consecutive actions represented by a pathway, whilst also indicating the combined result of the different measures at a specific moment in time.

In the previous pathways, the ATPs indicated the combined value of the actions taken prior to the sell-by date. Every addition of a new action meant a new ATP and a new sell-by date. In the modified pathway set-up, the ATPs indicate the combined value of the partial (or full) realisation of all measures, at the moment of the sell-by date. Further realisation of every measure means a new ATP and a new sell-by date, but these are only indicated for the six different implementation steps. In other words, the gradual realisation of the measures is considered as clustered over six implementation steps, for simplification, and for these six steps the ATPs are defined.

This was done because it was considered more useful to be able to express the implementation gradually over time (simplified to six steps), rather than expressing the implementation in one single step per measure (see Figure 5.4).

Because the ATPs are expressed for the (partially) realised measures *combined*, the number of implementation steps determines the number of ATPs that are defined in the pathways. Expressing the realisation of the

measures in more implementation steps, representing a more gradual and realistic implementation of the measures, increases the complexity of the pathways map because more information will be added to the illustration.

However, the modified pathway set-up in Figure 5.6 show the functionality of the pathways map to review the feasibility of the implementation and the planning of a design alternative without going into incomprehensible or time-consuming detail. Naturally, going into further detail, specifically in creating more gradual implementation steps and defining more ATPs, can be done in a later stage or parallel to the pathways map, i.e., excluded from the illustration.

#### 5.2.1.5 New time-objective relation

As previously discussed in Section 5.1.6, there is a large time lag between the current situation and the aimed situation for 2030, 2050 and 2085 according to the climate projections and the policy objective. The implication of this is that the ATPs cannot be interpreted with the time axis, i.e., the sell-by dates cannot be defined. As such, the ATPs are reduced to merely indicating the effectiveness of the undertaken action. This results in the fact that for this part of the pathways – when the deficit of the actual situation to the target value at the time still exists – the actions cannot be regarded in terms of time or as part of a planning over time.

The implication of this is that the sell-by dates of the ATPs cannot be interpreted with the time axis as included in the previous pathways in Figure 5.4. This results in the fact that for this part the pathways, the actions cannot be regarded in terms of a planning over time.

To be able to express the sell-by date of the ATPs as well as the timing of the decision- and execution nodes, a new timeline was added to represent the period between the current situation and the moment when the climate projections and objective is caught up with. This timeline is shown in blue at the top of the pathway map in Figure 5.5, and it shows a linear timeline from the current situation to

2085, as indicated by the climate projection for the worst-case scenario.

The new timeline in the modified pathway set-up gives a new meaning to the pathways and ATPs, in relation to the original set of pathways: if the pathways are followed and the incremental actions are taken before the ATPs are reached, it means that the measures are realised at a rate that is sufficient to reach the originally set objective in 2085.

This new interpretation of the ATPs is illustrated in Figure 5.8. Figure 5.8a-d shows how the new timeline bridges the gap between the storage capacity of the current situation and the storage capacity required in the future, in terms of climate predictions. As shown in Figure 5.8a, the value the storage capacity required in 2085 was taken as the target point. This was done, because the further in the future the target point, the more feasible the objective for progress. The progress required to get from the current situation to the target value is indicated in Figure 5.8b. Figure 5.8c shows that this progress was considered as the 'new objective', for which the pathways can be

defined. Therefore, the new ATPs and sell-by dates will be defined for the new timeline and objective for progress.

This new timeline represents the period in which the climate objective has to be caught up with. The original timeline on the bottom of the pathway map in combination with the storage capacity values on the effectivity axis indicate a situation where the enhancing climate resilience gradually moves along with the development of the climate stressor. This is not yet the case, due to the explained time lag.

### 5.2.2 Other conditions

Apart from this, the chosen timing of implementation for the green and blue-green was arbitrary; it was done as soon as possible, if necessary for attaining the objective, and it was planned further in the future if it was possible. 10 shows the results for the pathway map that contains the pathways for the implementation of the design, following the renewal rate. The result show that when the

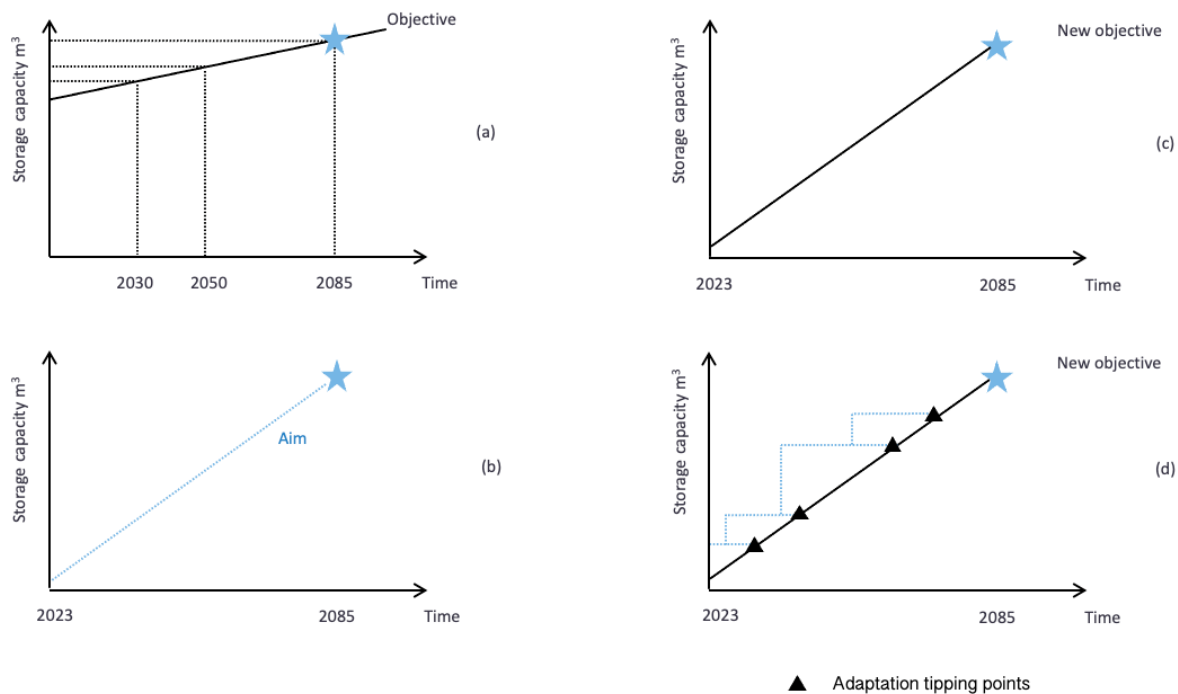

**Figure 5.8a-d:** Illustration of the new progress objective that is indicated with the new timeline in the modified pathway set-up, that represents the period that bridges the gap between the current situation and the target value for storage capacity, in terms of the climate projections.

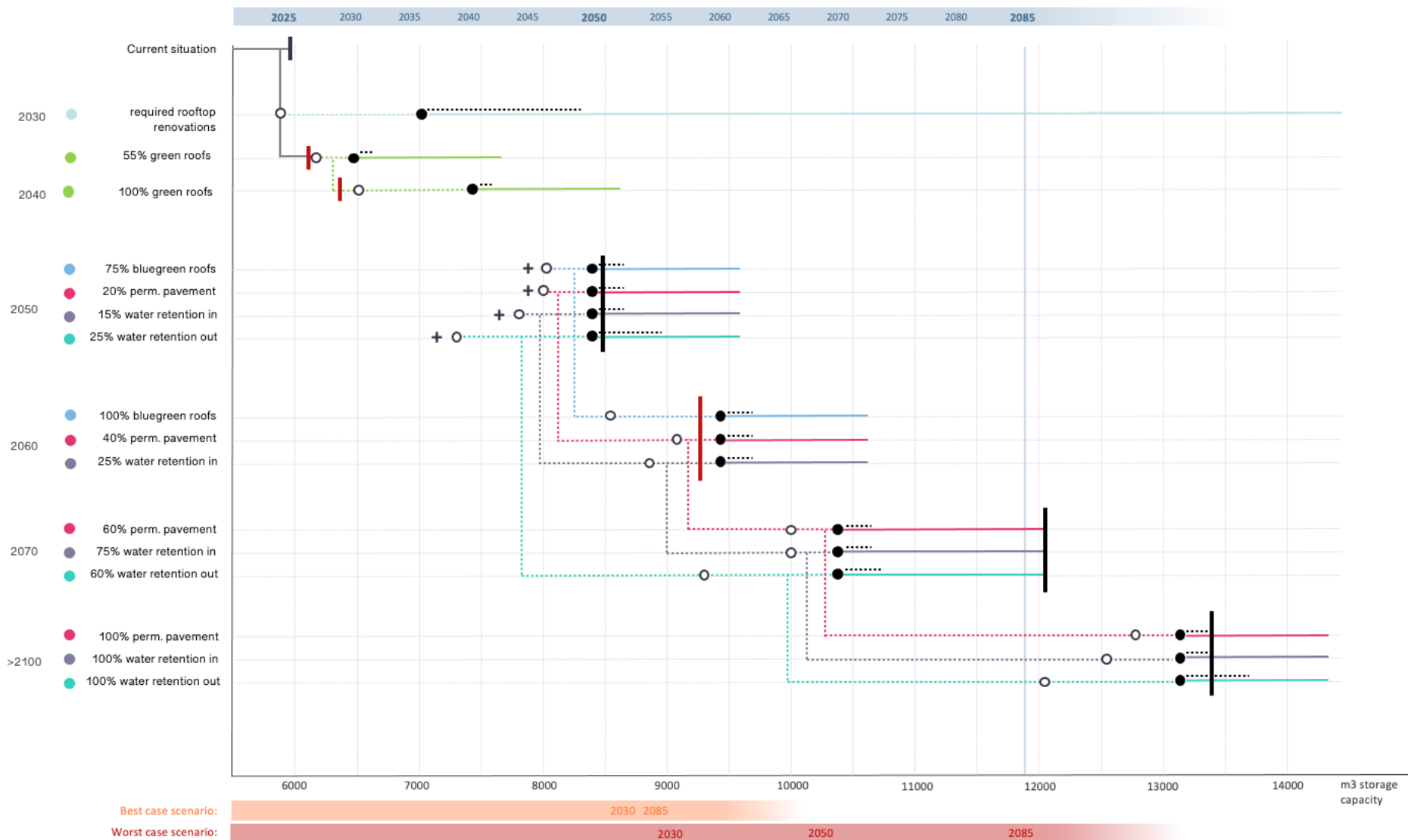

**Figure 5.10:** Discontinued pathways in the modified set-up illustrating the implementation of the design under the renewal strategy, following the moments of renewal of pavement in the public space, for the case study in Bosleeuw. The progression (%) of the realisation of the measures is plotted on the y-axis, the resulting storage in m<sup>3</sup> is plotted on the x-axis. Beneath the x-axis, the corresponding moments in time according to the climate predictions is illustrated. The year 2085 for the worst-case scenario is indicated with the blue line. At the top of the map, an additional timeline is plotted that represents a linear progression of time between the storage capacity of the current situation and the target value of 2085, in the worst-case scenario.

measures are realised at the rate of the renewal of pavement, the objective is barely met – or not at all met – and the adaptation tipping points (ATP) and thus the pathways cannot be fully defined. To elaborate, the ATPs indicate the amount of storage capacity that is created by the measures taken at that point and indicate the moment in time when the climate stress increases further, and the set objective is no longer met (sell-by date). Under the circumstances of the renewal rate, the measures are implemented too late, i.e., at the moment of implementation, the climate stress is further developed such that the amount of storage capacity created is already insufficient to meet the objective. In this situation, the ATP cannot be defined, because the sell-by date is already in the past. To illustrate the amount of storage created at the implementation steps, *inexistent* ATPs were added to the map and are shown in red to the measures of 2030, 2040, and 2060.

The ATPs for the implementation steps of 2050 and >2100 are *existent* in the sense that the amount of storage created at the moment of the execution of these measures is higher than the objective, i.e., the ATP is at the righthand side of the execution nodes. However, the distance between the execution nodes and ATP is so small, that the execution process is not

even finished before the sell-by date is reached. Therefore, these ATPs and pathway sections do not indicate a preferable situation where the measures are effective in attaining the objective. A preferable situation would be a moment in time in which the priorly realised measures are sufficient to attain the objective, and there is ample time to implement new measures to adapt to the developing stressor. Naturally, this is what is strived when considering possible pathways. However, the pathway map in Figure 5.10 illustrates that it is difficult to use the pathways to express the implementation of measures in an opposite situation, when the objective is not achieved.

Figure 5.11a and 5.11b depict the difference between the situation of realising this design at the rate of the renewal strategy and the preferable situation, for which the adaptive pathways are suitable. It illustrates the difference between being ‘behind on schedule’ and ‘being ahead of schedule’, which enables the situation where you can adapt to and move along with the developing stressor.

The main take-away is that the applicability of the adaptive pathways to a situation in which the set objective is not (continuously) achieved is limited, because the adaptation tipping

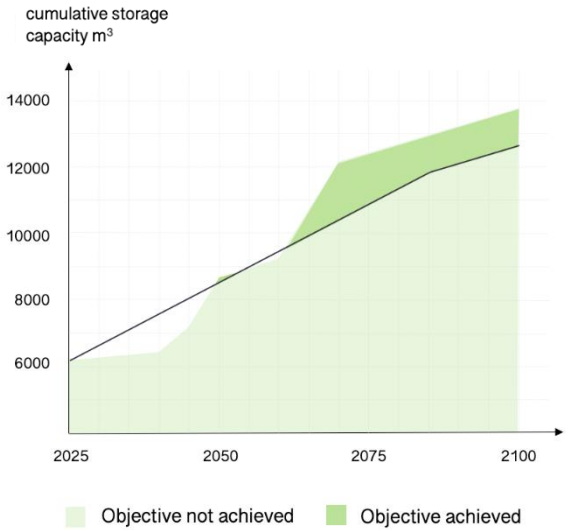

**Figure 5.11a:** Illustration of the situation in which the implemented measures only achieve the objective around ±2060, when limited by the rate of renewal of pavement in the public space.

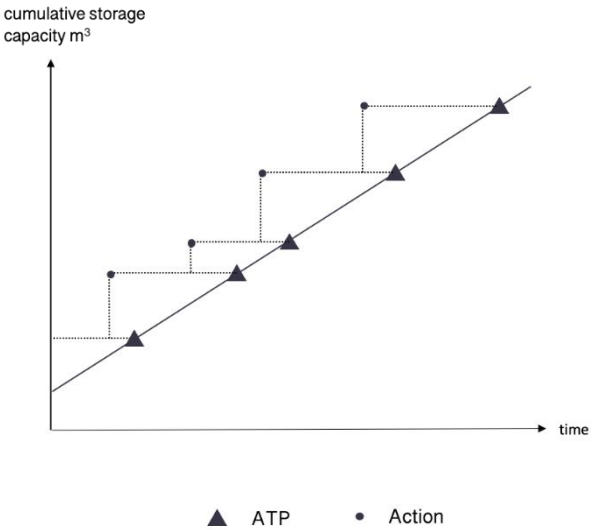

**Figure 5.11b:** Illustration of the situation in which the effectiveness of the measures > the objective value and the pathways and adaptation tipping points can be defined.

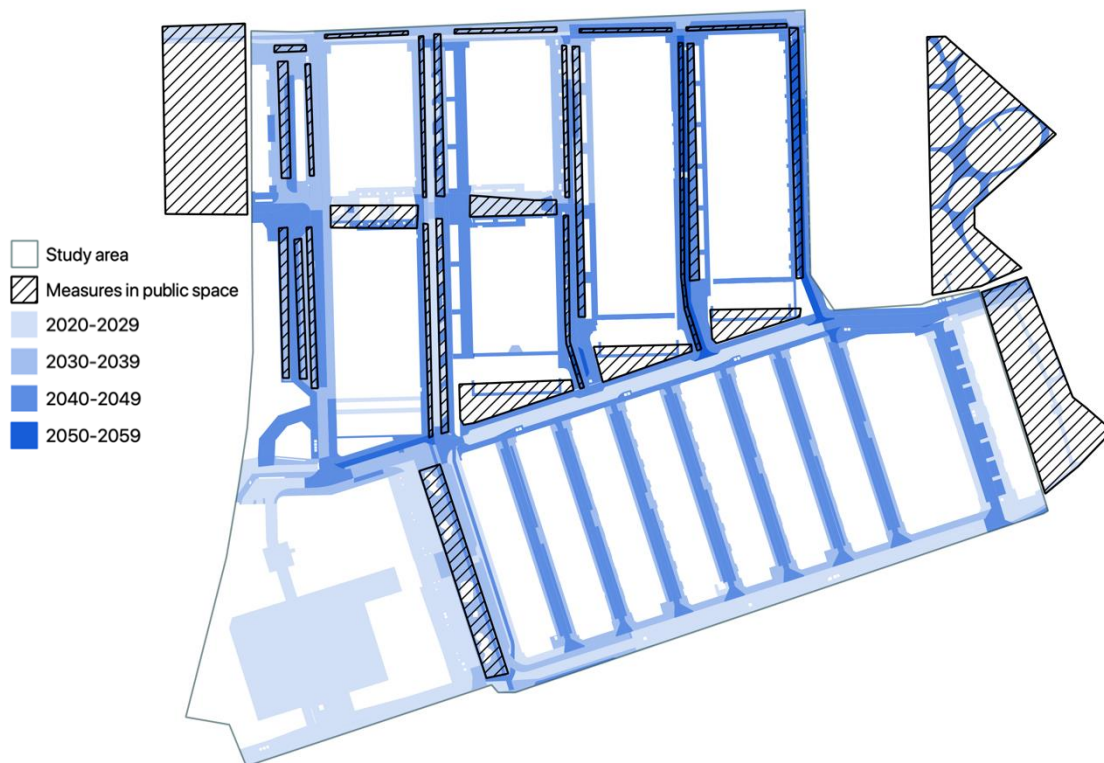

**Figure 5.12:** Expected moment of maintenance of pavement in the public space in the case study area in Bosleeuw, Amsterdam. Adapted from “Langetermijn vervanging Bosleeuw” by Gemeente Amsterdam (n.d.-a) [dataset].

points – a key element to the approach – cannot be defined for such a situation.

### Insights for case-study

In addition to new insights gained on the functionality of the pathways, some remarks can be made about the implementation strategy according to the rate of renewal in the study area in Bosleeuw.

As is shown in Figure 5.11a, implementing the measures at the rate of renewal is insufficient to continuously attain the objective. The pathways show that the objective is expected to be met around 2070. Important to note is that here we talk about the objective according to the new timeline in the modified pathway set-up: the objective to get from the current situation to the target value in 2085. For the actual climate projections, the objective value for storage capacity increases even faster, resulting in a greater deficit.

The comparison between the new timeline and the climate projections will be discussed further later, after the results for the maintenance rate and sewer rate are also shown.

### Maintenance rate

Figure 5.12 shows the expected moment of maintenance of the pavement in the public space. With this data, new pathways were developed where the execution of measures in the public coincides with the planned moment of maintenance of the locations. The resulting implementation steps are in 2030, 2040, 2050 and 2060.

For the green and blue-green roofs, the same panning was applied as for the pathways for the renewal rate.

The pathways for the implementation of the measures under the condition of the renewal

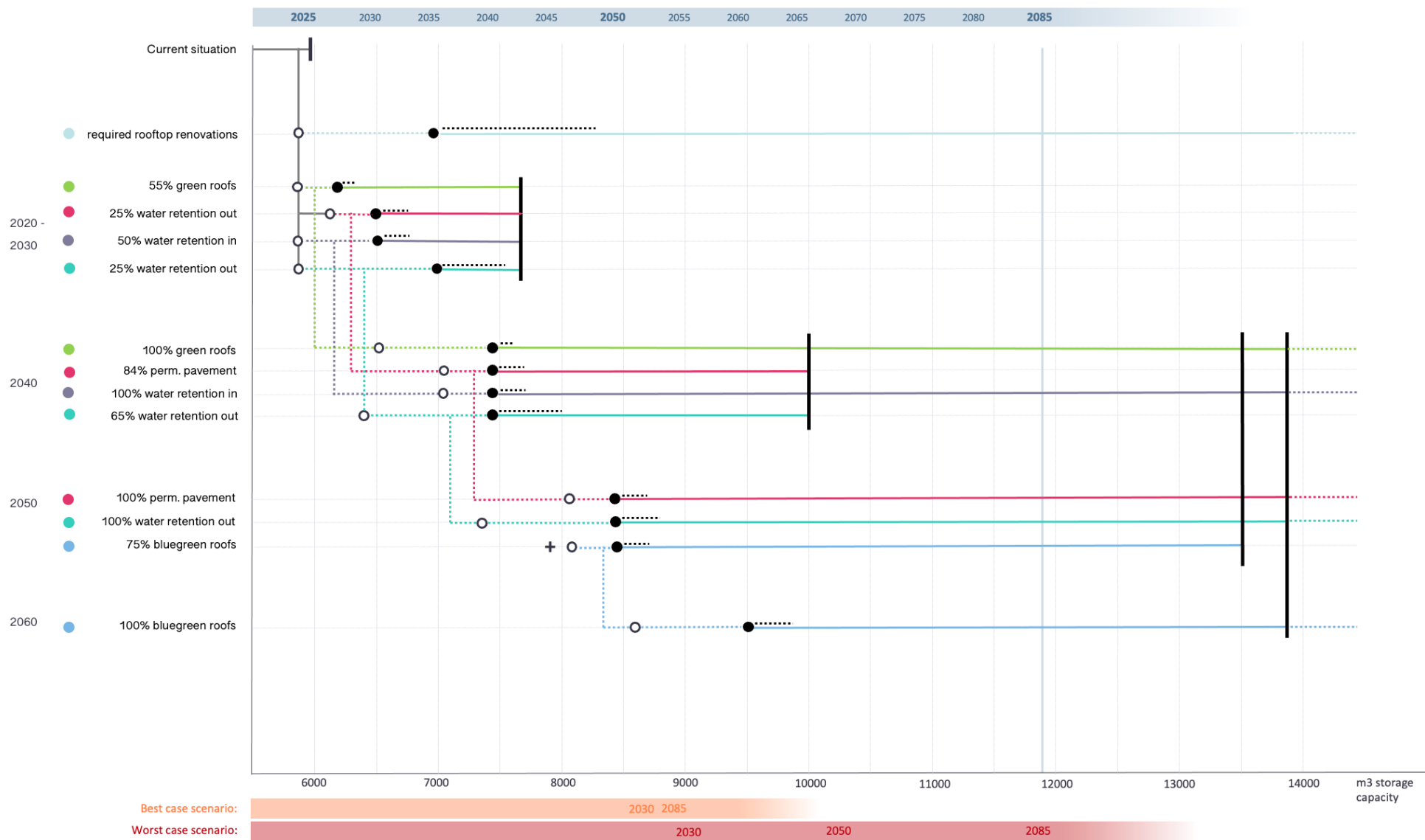

**Figure 5.13:** Pathways in the modified set-up illustrating the implementation of the design under the renewal strategy, following the moments of maintenance of pavement in the public space, for the case study in Bosleeuw. The progression (%) of the realisation of the measures is plotted on the y-axis, the resulting storage in m<sup>3</sup> is plotted on the x-axis. Beneath the x-axis, the corresponding moments in time according to the climate predictions is illustrated. The year 2085 for the worst-case scenario is indicated with the blue line. At the top of the map, an additional timeline is plotted that represents a linear progression of time between the storage capacity of the current situation and the target value of 2085, in the worst-case scenario.



strategy at the rate of planned maintenance are illustrated in the pathway map in Figure 5.13. The pathway map shows that at this rate, the set objective is continuously achieved. All measures are fully implemented before the following sell-by dates are reached. Moreover, the created storage capacity increases significantly faster than the previously presented pathways. The reason for this is the early implementation of the highly effective measures, the water retention areas. By 2045, all water retention areas inside the study area and 65% of the water retention areas outside of the study area are realised. This is so effective, that the sell-by date of this group of measures can even be expressed through the original timeline of the climate projections: around 2045-2050, according to the worst-case climate scenario. In 2050, the new group of measures is implemented, and by 2055, the new sell-by date is over 2085.

Notably, the planning of the implementation of the measures according to the rate of planned maintenance, is more ambitious than the planning according to the rate of renewal or the planning according to the arbitrarily ordered pathways presented in Figure 5.6 in Section 5.2.1.

### **Sewer rate**

In the Municipal Sewer Plan 2022-2027 (OPR), the municipality of Amsterdam discusses the replacement challenge of the sewer system the city is faced with. There is  $\pm 3900$  kilometres of sewer in Amsterdam, and the share of the sewer system that needs renewal is larger than the authorities can comfortably handle (Gemeente Amsterdam, 2022). Because over the years, less sewer was replaced than was required, the OPR emphasizes the guideline that because of the lifespan of the sewer infrastructure of  $\pm 60$  years, every year 65 kilometres of sewer is to be replaced. At this rate, the entire infrastructure will be replaced in 60 years, by 2085.

Considering this replacement guideline as the average sewer renewal rate, an average implementation rate for the design for the case study could be derived. It was assumed that the

gradual replacement of sewer over 60 years results in the gradual realisation of all measures over this period of 60 years.

This is plotted in Figure 5.14, showing that with the sewer renewal rate (e), over of 60 years, all measures are gradually realised and that this is a sufficient rate to achieve the objective continuously. The other graphs show the implementation rates for the renewal and maintenance of pavement. The developing objective adopted in the modified pathway set-up and the original objective according to the climate predictions are plotted. The figures show the rates of change in storage capacity compared to the objective of the climate scenario, the modified objective with the target value in 2085 and with the target value in 2050, i.e., a more rapid change in required storage capacity. The comparison is made with the objective of reaching the climate objective by 2050, because this objective is mentioned in the municipal policies in Amsterdam (Gemeente Amsterdam, 2022; Gemeente Amsterdam, 2021a).

The graphs in Figure 5.14 summarize the findings exploring the implementation rates according to the renewal strategy. The graphs show the large difference between the implementation rates and give an indication of when the objective will be attained. Firstly, it can be seen that the rate of maintenance of pavement and the rate of renewal of sewer are significantly more effective in attaining the of developing objective with the target value of 2085, then the renewal rate of the pavement. Figures 5.15c and e show that the objective is continuously met.

Secondly, the graphs illustrate how that the objective according to the worst-case climate scenario is met later than the modified objective. The climate objective is met the earliest for the rate of the maintenance of pavement and the latest for the rate of renewal of pavement.

Thirdly, the figures show that the modified objective with the target value of 2050 is less feasible than the modified objective for the target level of 2080.

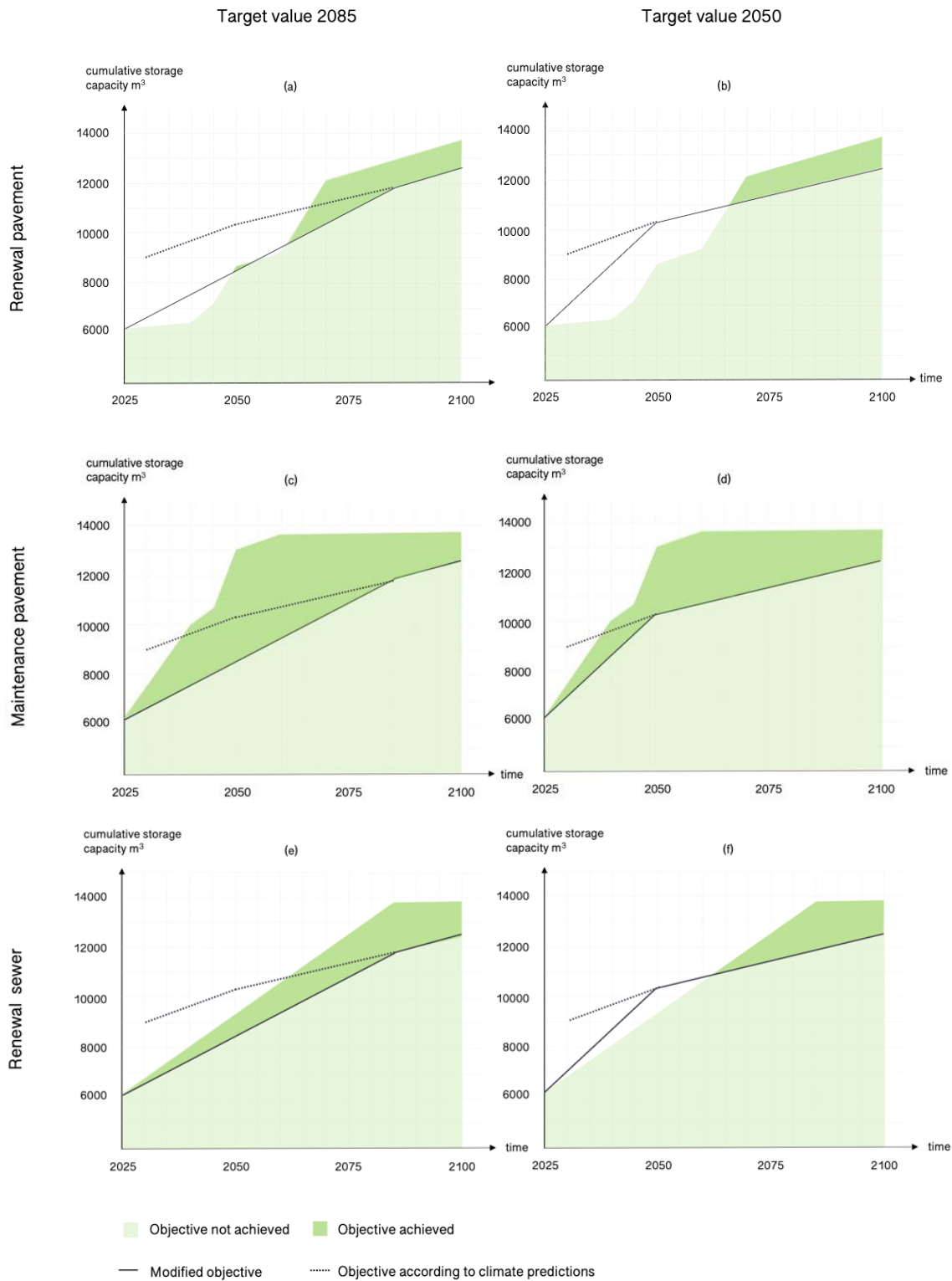

**Figure 5.14a-f:** Rates of change in cumulative storage capacity for the implementation according to the renewal strategy, for the renewal of pavement (a, b), maintenance of pavement (c, d) and the renewal of sewer (e, f), compared to the objective according to the worst-case climate scenario and the modified objective for the target value of 2085 (left) and 2050 (right).

Realistically, the average rate at which the future spatial adaptations in the study will likely occur will be somewhere in between the three rates illustrated in this section. Thus, these rates can be considered as the temporal boundaries in between which the actual implementation rate will occur. In that regard, it is an important notion that under the condition of the renewal rate of pavement, it will take around forty to fifty years to reach the objective set by the Municipality of Amsterdam, when considering this design. In order to attain the objective faster, it is necessary to also let the timing of maintenance to pavement and renewal of sewer infrastructure be leading for planning the realisation of climate adaptive measures.

Important to note is that the implementation time required for the measures is not considered in these graphs. The storage capacity is considered realised at the start of the execution process. In addition, because the implementation of the measures is grouped over the implementation steps, the realisation of storage capacity is observed as stepwise over the six implementation steps. In the graphs in Figure 5.14, a linear progression is drawn to illustrate the realisation of measures.

#### **5.2.4 Findings**

The modifications to the pathways and experimenting with the new set-up under the conditions of the renewal strategy, lead to several findings.

The foremost finding is that the modified pathway set-up is functional to reviewing the feasibility of the implementation and planning of a design alternative without going into time-consuming or incomprehensible detail. This was realised by incorporating the duration of implementation for each measure. The pathways and the adaptation tipping point can now be interpreted as a more shared perception of feasible paths that attain the set objective. As a result, the pathways can be used as a tool to back cast required actions and implementation steps.

Furthermore, the addition of the new time axis allows for the expression of moments of action and adaptation tipping points (ATP) in terms of a sell-by date. This way, it is possible to view actions and ATPs in a planning as part of a rate of progress over time. Without this addition, the ATPs merely expressed the cumulative effect of the realised measures, rather than indicate a moment in time when additional action is required.

It is important to note that this new timeline on which the ATP's are conditioned, represents a target implementation rate to get from the current situation to a target value for rainwater storage capacity in the future. For this timeline to uphold, an iteration would be necessary to calibrate the new axis if the development of the system stressor – in this case, pluvial flooding – deviates from the considered predictions – in this case, the climate scenarios.

In this regard, increasing the focus on the planning and implementation time of the measures, the element of incorporating uncertainty has become less prominent. The pathways following to the DAPP approach include the concept of expressing the planned moment of actions and ATPs in terms of how far the uncertain development has progressed, rather than in time. Adding the two transient climate scenarios gives an indication of an expected time range for the moment of occurrence. This enables the identification of important decision- and action nodes, without knowing when these moments will occur. This ability is reduced in the modified set-up because the planning of action over time is emphasized in higher detail.

Another important element of the pathways with the DAPP approach is the ability to postpone decisions to a moment in the future, in order to prevent overinvestment and suboptimal design choices. By developing a set of pathways, parallel alternatives are reviewed, and it leaves options open. This feature is not present in the modified set-up of the pathways, as the pathways represent the implementation of a single design alternative. It is an important observation that in enabling the new features

in the modified set-up, this key characteristic of pathway thinking is eliminated.

An advantage of the modified pathway set-up is that it contributes to the planning of the implementation of a rainwater resilient design at neighbourhood scale. Developing the pathways in this set-up facilitates a spatial and temporal overview of required actions to attain the objective. In this way, it provides a planning tool that can guide the process of decision-making for rainwater resilience and support the monitoring of the adequate implementation to attain a set objective.

Reflecting on these findings, it can be concluded that the modified set-up of the pathways should be viewed as complementary to the DAPP approach, and not as a replacement. The key elements of the DAPP approach and the advantages of the modified set-up that enable the planning of the actions in the pathways complement each other. The modified set-up serves as a more detailed view of the implementation of a single design, that can follow the insights and considerations of comparing a set of alternatives with Dynamic Adaptive Policy Pathways in a decision-making and planning process.

### **5.3 Contribution to planning process**

Finally, it is considered whether the DAPP-approach and the modified set-up can make a positive contribution to the planning process for spatial redesign.

First of all, it is important to note, as the results in Chapter 4 showed, that embedding the stress of pluvial flooding as a design principle in the planning process for spatial adaptations in the public space (the PBI), is a necessary condition. As analysis of the case study with the DAPP-method showed, obtaining the objective

for water storage capacity implies that all moments of maintenance and renewal of pavement or other infrastructures must be used. Integrating pluvial flooding in the planning process for spatial redesign, thus is key! In this regard, Amsterdam Rainproof has initiated the integration of a climate resilience check in the PBI that will require rainwater resilience under the municipal norms for all spatial adaptations in the existing public space.

Besides this, the spatial adaptive policy pathways can contribute to strengthening the strategy for rainwater resilience. Primarily, the spatial application of the pathways for pluvial flooding demonstrated the ability to not only consider future design alternatives but to plan required actions over time. The results showed that in this set-up, the pathways enable the planning of measures by considering long-term objectives, short-term actions as well as the feasibility of the implementation of measures.

Thus, the pathways can provide a spatial as well as a temporal overview of the implementation of a strategy. Additionally, it contributes to the cohesiveness of spatial design at neighbourhood scale because it reviews rainwater resilience at this scale. Furthermore, it connects measures in both public and private space and explicitly integrates the required responsibility of private parties in reaching the objective.

Because of these findings, it is concluded that the spatially applied adaptive pathways can contribute to the structural rather than incidental implementation of rainwater resilient spatial design. Within the planning process, it can function as a planning instrument or design guideline, e.g., a roadmap for long-term design, at neighbourhood scale, as well as a monitoring tool for progress towards a set objective.

Chapter 6

# **Discussion**

In this chapter, the approach and results of this research are discussed. The limitations of the approach are discussed per research question in Section 6.1, including important assumptions and limitations specifically for the case-study. In Section 6.2, the findings are compared to previous work that exists on adaptive pathways. The transferability of the results is reflected upon in Section 6.3.

## **6.1 Limitations of approach**

### **6.1.1 SQ1**

To answer the first sub-research question, the planning process of spatial redesign of existing urban areas in the city of Amsterdam was analysed to see to what extent the stress of pluvial flooding was considered in it.

The analysis relied on policy documents related to climate adaptation planning in the Netherlands and Amsterdam. For the selection of relevant policy documents, personal knowledge gained during the internship at the municipality of Amsterdam was used. A personal bias possibly influenced the perception of the level of importance of policies. Moreover, relying on grey literature as a main source of information introduces possible inherent bias, as policy documents reflect certain political and institutional constraints. As a result, grey literature is possibly more subjective and politically influenced. In addition, the thematic policy documents included showed a focus on the best practices and guidelines. Merely focusing on this source of information, although widely supported, limited the understanding of how the planning process functions in practice.

### **6.1.2 SQ2**

To answer the second research question, dynamic adaptive policy pathways were developed for a case-study in Bosleeuw, Amsterdam. A number of generalizing assumptions were made, to be able to do so within the scope of this study.

Firstly, for the objective for rainwater resilience set by the municipality of Amsterdam, an extreme interpretation was adopted in this

research. The set objective says that the city should be able to process rainwater with sufficient capacity in order to suffer no damage at a rainfall event with a return period of  $T = 100$  years, which corresponds to 70 mm and 81 mm per hour in 2050 and 2085 respectively. It was assumed that the entire rainwater volume should be stored in order to 'suffer no damage' and that the water must be stored within 60 minutes, i.e., water is not allowed to accumulate in the streets and should be processed within an hour after the start of the rainfall event. Therefore, the storage due to time-dependent fluxes (infiltration and sewer pumping) is limited to the volume that can be processed in one hour. Provided that the available storage in the subsurface allows it, the infiltration volume could be significantly higher if water is accepted in the streets for a longer period of time. For this case-study, this interpretation of the objective means that the required future storage capacity is exaggerated, and that the feasibility of rainwater resilience in reality is higher than the findings of this research indicate. Consequentially, the inflexibility in choosing measures that the municipality is faced with in this case-study, as well as the insufficiency of the rate of change of the renewal strategy in attaining the set objective are overestimated in this research.

The decision to include or neglect interception in the water balance model had a significant impact on the available water storage. In this case study, assuming an interception depth of 10 mm, the interception volume accounted for nearly 7% of the total potential water storage capacity in the area. This highlights the importance of considering interception as a contributor to urban water storage, which is often overlooked. This becomes particularly relevant in the context of accepting water in the streets after extreme rainfall events as part of a paradigm shift in addressing pluvial flooding. It is recommended to use a more detailed urban water balance model, such as the 'Climate Resilient City Tool', which allows for detailed modelling of land surface types, subsurface conditions, and climate adaptive measures. Such a model would provide a more accurate assessment of potential storage

capacity, increasing the precision of the analysis and supporting informed decision-making.

The realised storage capacity on the blue-green roofs was defined as independent of the rainfall intensity, which leads to a slight overestimation of the storage capacity in the case of a rainfall event with less than 81 mm of rainfall. The storage capacity appointed to the blue-green roofs is 81 mm of rainfall, based upon the design rainfall event of 81 mm/h. This leads to a discrepancy in the pathways, for the period before 2085, between the required m<sup>3</sup> of storage are calculated with a rainfall intensity that coincides with that moment in time in the climate predictions, and the realised storage capacity due to blue-green roofs which was calculated with the design rainfall intensity of 81 mm/h. This error, however, is less than 2.8% for all design alternatives considered.

The rainwater storage capacity was determined without considering the rainfall runoff pathways, i.e., it was not considered how the stormwater is discharged to the designated storages. Approaching the assessment of the storage capacity of the area with a bucket water balance model, the identified stores were considered independent from fluxes. As such, the focus was on the storage components, rather than their interconnections. This is especially important for the water retention areas, because these have a large catchment compared to other measures considered. In this case-study it was assumed that the stormwater reaches the water retention areas regardless. For this study, this means that the estimation of the potential storage capacity is conditional to the actualisation of the street design presented in the Solution Map (see Section 2.1), as the design of the water retention areas coincides with the design in the Solution Map.

## 6.2 Spatial scale

By developing the pathways for pluvial flooding for a study-area at a smaller scale than the hydrological unit, the hydrological connectivity with the surrounding area was neglected. The

Solution Map that was taken as a guideline for the rainwater resilient design of the area was made at the scale of the hydrological unit. The hydrological unit is seen as a hydrological entity in which water quantity issues should be approached, because of the spatial connectivity within the area. By looking at a study-area at a smaller scale, preferential solutions that stem from the spatial connectivity with the surrounding area might be overlooked. If neighbouring areas have a higher (potential) storage capacity and possibly even a storage surplus during extreme rainfall events, it could be lucrative to drain water over the boundaries of our chosen study-area. The study into such possibilities should be done prior to the development of pathways at the level of detail shown in this thesis, e.g., by means of a Solution Map.

The spatial scale for which the pathways are developed should be carefully considered. As described above, the smaller the spatial scale, the more the spatial connectivity with surrounding area is overlooked. This could be countered with an overarching area analysis to connect the potential solutions of neighbouring areas within the hydrological unit.

If you look at a larger spatial scale than the case-study, the spatial connectivity between the different measures will decrease. If for a larger study-area the measures become more sparsely distributed, the assumption that the rainfall runoff pathway can be neglected and that stormwater reaches the water retention areas regardless, becomes invalid. Thus, the rainfall runoff and the catchments of each measure should be analysed at a higher level of detail, in comparison to the approach presented in this study, to assess the actual storage capacity that would be realised.

Furthermore, if the pathways are developed for a larger spatial scale, the increase in variety in urban typologies could result in a larger set of adequate and possible solutions, increasing the measure set. When applying the pathways at the level of detail as presented in this study, the addition of more information into a set of pathways leads to a more complex pathway

map. Moreover, the different actions and their pathways will be increasingly independent from the other pathways for a larger study area, covering multiple urban typologies. The more independent two actions are, the less value there is in expressing the trade-off between the two options in a set of pathways. Then, a point is reached where the adaptive pathways with an increased level of complexity is not the most fruitful approach. It would be advisable to apply the pathways in a more abstract manner to a larger spatial scale to support decision-making at this level.

### **6.3 Comparison to previous work**

In this research, adaptive pathways were developed for rainwater resilient design of an urban area in Amsterdam. The level of detail in the pathways presented in this study is higher than the Dynamic Adaptive Policy Pathways (Haasnoot et al, 2012; Haasnoot et al, 2013) that were introduced at the start of this research. This refers to both the spatial design options that are represented by pathways and the planning of the implementation of the design in the modified pathway set-up. This difference can be explained with the fact that for this case-study, the pathways approach was applied in an advanced phase of the planning process: a phase in which concrete design choices and spatial adaptations are compared. The pathways presented by Haasnoot, on the contrary, are developed in a more explorative context, and consider the impact of policy- and design choices at a larger spatial scale and on a more abstract level (2012). This is an important notion when assessing the findings of this research and comparing the level of concreteness of the pathways for this case-study to previous work.

### **6.4 Transferability**

The findings of the case-study have broader implications beyond the boundaries of this specific study area. The study area was modelled with a simplified bucket model that

considered surface types (paved surface, permeable pavement, green surface, open water), available potential water retention areas, available flat roof surface and an average groundwater table. For urban areas with comparable surface type distributions and proportions of flat roof surface, the pathways can offer insights into the possible solutions and the required implementation strategies.

Looking at Amsterdam, this is the case for other neighbourhoods in Amsterdam West. Figure 6.1 shows the composition of the surface types in the public space in Bosleeuw, in Amsterdam West and in the whole of Amsterdam. The similarity between Bosleeuw and the rest of Amsterdam West is strengthened comparable urban typology in terms of the housing, mostly three- or four-story buildings with flat roofs.

The other Stadsdelen show a variety of different compositions, shown in Appendix C. For these areas, the measure set has to be reconsidered and new pathways should be developed, but the findings for the set-up for adaptive pathways for pluvial flooding applies. This also goes for other urban areas.

The findings for the case-study in terms of the renewal strategy also provide insights for the issues concerning other climate stresses. The urban transition that is required for drought and heat stress specifically, is also very dependent on the renewal rate of infrastructures. The plotted rates of change according to the renewal and maintenance of pavement and renewal of sewer infrastructure shed light on the importance to closely monitor and use every opportunity for spatial adaptation that the renewal strategy offers.

However, to apply this approach to other climate stressors – or other urban stressors – a defined, and measurable objective must exist, in order to define adaptation tipping points and their sell-by dates.



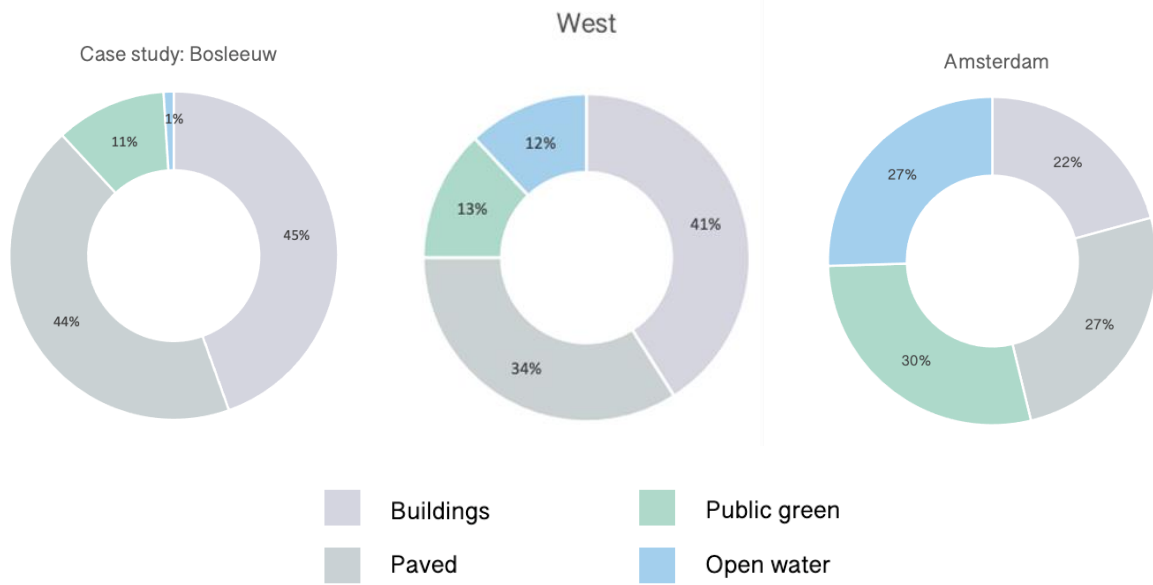

**Figure 6.1:** The surface types of the urban area for Bosleeuw, Amsterdam West and Amsterdam, differentiating between buildings (the share of the total surface area that exists of built-up area (public and private) including yards), paved (the share of the total surface area that exists of unbuilt paved area, such as roads), green space (the share of the total surface area that exists of living green in the public space), and water (the share of the total surface area that exists of inland open water). Adapted from “Gebied in Beeld” by OIS Gemeente Amsterdam (n.d).



Chapter 7

# Conclusion

This study aimed to find out how spatially applied adaptive pathways can contribute to rainwater resilience and to the integration of the stress of pluvial flooding in the planning process of spatial redesign of existing urban areas, for the case of Amsterdam. First, the planning process of the municipality of Amsterdam for spatial redesign and the relevant policy documents were analysed to comprehend the dynamics of climate adaptation planning in the city's administration. Second, an experimental set of adaptive pathways was developed and illustrated for a redesign scenario for a study area in Amsterdam West. The objective was to explore how this the concept of adaptive pathways can be used for rainwater resilience and to determine how adaptive pathways can contribute to climate adaptation planning for redesign in Amsterdam.

**RQ:** How can Spatial Adaptation Policy Pathways contribute to the integration of the stress of pluvial flooding in the planning process of spatial redesign of existing urban areas, for the case of Amsterdam?

### **Planning process for spatial redesign**

The research shows that the municipality of Amsterdam and Waternet are mainly responsible for the design and implementation of spatial adaptations to make the urban environment more resilient to the stress of pluvial flooding. The analysis of policy documents and the planning process regarding spatial adaptation reveals that there is a significant gap between the thematic policy objectives and the actual projects that are carried out. The official policy documents and the “Plan- en Besluitvormingsproces Infrastructuur” (PBI) are insufficiently aligned. On the one hand, in the thematic policies, formulated by the city's policy makers, ambitious local strategies are defined, and climate robust design is presented to be the guiding principle for all projects in the public space. On the other hand, all projects in the public space are governed by the PBI. The PBI organises the whole process from policy objective to actual project. As such, you would expect to find climate stresses and thus pluvial

flooding as important designing principles in the PBI, guiding the formulation of actual projects. As the analysis in Chapter 4 shows, this is not the case. Although becoming climate resilient is a major policy objective for the city of Amsterdam, once the projects reach the stage of concrete spatial redesign (see the PBI) climate resilience is no longer the dominant, steering principle.

Results illustrate that the ambitions and strategies for rainwater resilience need to be incorporated in the PBI for it to be anchored in the actual planning process. One of the consequences of this being not the case, is that the necessary capacity to deal with the stress of pluvial flooding does not have to be assessed. As a result, there is room for the realization of redesigns that are not adapted to climate stress. The results of the case study of Bosleeuw show that because of the long lifespan of infrastructural objects, such missed opportunities have a significant negative impact on the transition towards a rainwater resilient Amsterdam.

### **Adaptive pathways**

In the second part of this study, it was analysed whether the use of spatially applied adaptive pathways would be helpful in closing the perceived gap between policy objectives on pluvial flooding and the spatial adaptations carried out in the city. It was found that the adaptive pathways can contribute to rainwater resilience planning by providing a guiding spatial and temporal overview of required actions to support decision-making and the monitoring of adequate implementation of spatial adaptations.

The results of the development of pathways for the case-study following to the Dynamic Adaptive Policy Pathways (DAPP) showed that these pathways were not indicative of some implicit complexities with regards to the planning and realisation of the pathways. The adaptation tipping points (ATP), and the decision-nodes together did not give an indication of the required moment in time for consecutive actions, nor did the pathways include information on the implementation time of measures. As the results showed, there was a significant discrepancy between the

current storage capacity in the study area and the target value for 2030, according to the climate predictions. Because of this discrepancy, the sell-by dates of the ATPs before reaching the objective could not be defined. Thus, these ATPs were reduced by merely expressing the effectiveness of the undertaken action and are not indicative of a moment in time. And lastly, this use of the pathways for rainwater resilience specifically was limited in presenting parallel alternatives with a range of flexible open choices in the future because i) almost all measures in the included measure set were required to attain the objective and ii) the frequent splitting of pathways reduced the number of solutions that could be included in the pathway map.

For the case study of Bosleeuw specifically, the results revealed that it is *all hands on deck*: almost all actions are required to create sufficient fast rainwater storage by 2085. This led to the notion that little flexibility is left in choosing between measures and design alternatives.

Furthermore, the pathways showed the majority of the rainwater storage can be realised in the public space, provided that water retention areas bordering the study area are created, as these are the most effective measures in a key step towards achieving the objective. Besides efforts in the public space, the private parties in the area are required to participate in order to reach sufficient storage. The ample flat roof space offers a lot of potential water retention. As water retention on roofs is quite an impact-full measure for these old buildings, the municipality has a formidable task in reaching out, informing, and educating the housing corporations, local businesses and other estate owners, to stimulate them to create the needed retention capacity.

#### **Modified pathway set-up**

In response to the findings about the use of the pathways following to the DAPP approach for rainwater resilience, several modifications were made to the pathway set-up that enhanced the functionality of the pathways to illustrate the feasibility of the implementation

of a solution. Firstly, estimations for the duration of the implementation process for every measure were included in the pathways, differentiating between the decision-making and execution process. Secondly, the implementation of the measures was grouped and divided over incremental implementation steps and per step, a shared ATP was identified for the combination of the measures realised at that moment in time. The ATPs indicate the combined value of the partial (or full) realisation of all measures, at the moment of the sell-by date. And finally, a new timeline was added to cover the catch-up period between the current situation and the moment that the climate projections are caught up with. This way, the sell-by dates of the ATPs could be defined in terms of a new timeline.

With the new modified pathway set-up, pathways were created for the selected design alternative under the conditions of the renewal strategy. Pathways were made according to the rate of change of the public space, following the planned renewal of pavement, maintenance of pavement and the renewal of sewer infrastructure.

For the case study of Bosleeuw, the results showed that the renewal rate of pavement was not sufficient to continuously reach the objective. Only around 2070 was the objective according to the climate projections met. On the other hand, the rate of change of maintenance of pavement showed the most advantageous for attaining the objective for rainwater storage capacity. The results indicated that the target would be attained around 2040. Following the rate of change of sewer renewal, the objective would be reached around 2060. Overall, these experiments illustrated that there is little margin in attaining the objective for rainwater resilience set by the municipality of Amsterdam. Thus, it is of great importance that all opportunities for climate adaptive spatial adaptations are benefited from.

With regards to the use of the modified set-up of the pathways, the following conclusions are drawn.

The foremost finding is the functionality of the modified pathway set-up to review the feasibility of the implementation and planning of a design alternative without going into time-consuming or incomprehensible detail. The incorporation of the implementation time of measures allows for the back casting of required.

The results demonstrate that the adaptive pathways are unusable for developing an implementation strategy for a situation where the gap between the reality and the objective is too large, i.e., achieving the objective within a feasible time is impossible.

The results demonstrate that to be able to develop adaptive pathways for a situation where the gap between the reality and the objective is significant, the addition of a new timeline is necessary that bridges the discrepancy and represents a new rate of progression to attain the objective. The new timeline enabled the definition of the sell-by dates of the adaptation tipping points and the planning of actions over time. Considering the ambitious objective that Amsterdam has set for rainwater resilience, the addition of an adjusted timeline is likely to be generally necessary for the use of adaptive pathways for pluvial flooding.

However, because the planning of action over time was emphasized in higher detail, the important element of explicitly allowing uncertainty was reduced: the expression of planned moment of decision or action in terms of how far the uncertain development has progressed, rather than in time. Additionally,

as the pathways in the modified set-up represented the implementation of a single design alternative, the concept of postponing decisions to a moment in the future in order to prevent lock-ins was eliminated.

An advantage of the new pathway set-up is that it contributes to the planning of the implementation of a rainwater resilient strategy at neighborhood scale. Developing the pathways in this set-up facilitates a spatial and temporal overview of required actions to attain the objective. As such, it adds to the cohesiveness of spatial design at neighborhood scale. Additionally, it connects measures in both the public and private space and explicitly integrates the role that private parties have in reaching the objective.

Reflecting on the findings of the original and new sets of pathways, it can be concluded that the modified set-up of the pathways should be viewed as complementary to the DAPP approach. The new set-up enables a more detailed view of the implementation of a single design alternative that can follow the insights gained by considering a set of possibilities with the DAPP approach. Overall, the use of spatially applied adaptive pathways contribute to the structural rather than incidental implementation of rainwater resilient spatial redesign. It provides a planning tool that can support the process of decision-making for rainwater resilience strategies and the monitoring of the adequate implementation to achieve set objectives.

Chapter 8

# Recommendations

There are a few recommendations that can be made for further research. First, to better comprehend the functioning of adaptive pathways for pluvial flooding, it is advisable to further explore this use under different conditions. A limiting factor in this study were the conditions of the case-study, with regards to pluvial flooding, because of the combination of the strict and ambitious objective and the limited number of considered measures. As a result, there was little flexibility to choose between different measures in the design alternatives. It is advisable to explore the pathways for pluvial flooding for a different case-study with a milder objective, to better comprehend the role that of adaptive pathways can play in decision-making between parallel and uncertain future alternatives.

Moreover, it is recommended to further research the combination of advantages of the Dynamic Adaptative Policy Pathway approach and the modified set-up of the pathways. The two sets of pathways, although viewed complementary to each other, are seen as two separate entities. It could be lucrative to

experiment with the combination of the two: incorporating the duration of implementation into the pathways developed with the DAPP approach and explore a new interpretation of adaptation tipping points that can express the shared effect of a set of measures, within the set-up of the DAPP approach.

This research was a start in reviewing the possibility of using the spatially applied adaptive pathways for pluvial flooding. Although more research needs to be done, insights are gained to see potential for the use of these pathways for this climate stressor. It is recommended to do the same for the other climate stresses of heat, drought, and salinization, to find out what the potential is for these other themes.

Furthermore, it would be important to research if different climate- or urban stressors can be combined in a single pathways map or a set of maps. As the urban environment is a complex system with many intersectional systems and challenges, it is very interesting to see if a pathway could be expressed in terms of more than one development over time.



# Bibliography

- Bear, J. (2013). *Dynamics of Fluids in Porous Media*. Courier Corporation.
- Bogaard, F. & Lucke, T. (2019). Long-term infiltration performance evaluation of Dutch permeable pavement using the full-scale infiltration method. *Water* (11), 320.
- Bloemen, P., Reeder, T., Zevenbergen, C., Rijke, J., Kingsborough, A. (2018). Lessons learned from applying adaptation pathways in flood risk management and challenges for the further development of this approach. *Mitig Adapt Strateg Glob Change*, 23, 1083-1108. <https://doi.org/10.1007/s11027-017-9773-9>
- Brown, R., Keath, N., & Wong, T. (2009). Urban water management in cities: historical, current and future regimes. *Water Science Technology* (59.5), 847.
- Boogaard, F., & Lucke, T. (2019). Long-term infiltration performance evaluation of Dutch permeable pavements using the full-scale infiltration method. *Water*, 11(320).
- Cradock-Henry, N., Blackett, P., Hall, M., Johnstone, P., Teixeira, E., Wreford, A. (2020). Climate adaptation pathways for agriculture: Insights from a participatory process. *Environmental Science and Policy*, 107, 66-79. <https://doi.org/10.1016/j.envsci.2020.02.020>
- De Dakdokters. (2022). *Green roofs - De Dakdokters*. <https://dakdokters.nl/en/green-roofs/>
- Dias, L., Aparício, B., Nunes, J., Morais, I., Fonseca, A., Pastor, A., Santos, F. (2020). Integrating a hydrological model into regional water policies: Co-creation of climate change dynamic adaptive policy pathways for water resources in southern Portugal. *Environmental Science and Policy*, 114, 519-532. <https://doi.org/10.1016/j.envsci.2020.09.020>
- Gemeente Amsterdam (2019). Plan- en Besluitvorming Infrastructuur [https://131f4363709c46b89a6ba5bc764b38b9.objectstore.eu/hior/Documenten/PBI%2019%20\(2019\).pdf](https://131f4363709c46b89a6ba5bc764b38b9.objectstore.eu/hior/Documenten/PBI%2019%20(2019).pdf)
- Gemeente Amsterdam (2021). Uitvoeringsagenda Klimaatadaptatie <https://www.amsterdam.nl/bestuur-organisatie/vol-g-beleid/coalitieakkoord-uitvoeringsagenda/gezonde-duurzame-stad/>
- Amsterdam (2022). Omgevingsprogramma Riolering 2022-2027 Omgevingsprogramma Riolering (OPR) 2022-2027
- Gemeente Amsterdam (2016) Gemeentelijk Rioleringsplan 2016-2020
- Gemeente Amsterdam & Waternet (n.d.). Regenwaterbestendige Gebiedsontwikkeling – Thematische studie voor Ruimte voor de Stad. Katern 2.
- Gemeente Amsterdam. (n.d.-a). Langetermijn vervanging Bosleeuw [Dataset]. In Aanleg en vervangingcyclus Bosleeuw.
- Gemeente Amsterda. (n.d.-b). *Overzicht Bouw- en Verkeersprogramma*. Amsterdam.nl. <https://www.amsterdam.nl/projecten/overzicht/>
- Geneletti, D., & Zardo, L. (2016). Ecosystem-based adaptation in cities: An analysis of European urban climate adaptation plans. *Land Use Policy* (50), 38-47.
- Haasnoot, M., Middelkoop, H., Offermans, A., van Beek, E., van Deursen, W.P.A. (2013). Exploring pathways for sustainable water management in river deltas in a changing environment. *Climatic Change*, 115, 795-819.
- Haasnoot, M., Kwakkel, J.H., Walker, W. E., ter Maat, J. (2013). Dynamic adaptive policy pathways: A method for crafting robust decisions for a deeply uncertain world. *Global Environmental Change*, 23, 485-498. [doi.org/10.1016/j.gloenvcha.2012.12.006](https://doi.org/10.1016/j.gloenvcha.2012.12.006)
- Informatiepunt Leefomgeving. (n.d.-a). *Klimaatadaptatie per beleidsdomein*. <https://iplo.nl/thema/klimaat/klimaatadaptatie-per-beleidsdomein/>
- Informatiepunt Leefomgeving. (n.d.-b). *Taken en bevoegdheden grondwater*. <https://iplo.nl/thema/water/grondwater/taken-bevoegdheden-grondwater/>
- Kingsborough, A., Borgomeo, E., Hall, J. (2016). Adaptation pathways in practice: Mapping options and trade-offs for London's water resources. *Sustainable Cities and Society*, 27, 386-397. <http://dx.doi.org/10.1016/j.scs.2016.08.013>
- Kingsborough, A., Jenkins, K., Hall, J. (2017). Development and appraisal of long-term adaptation pathways for managing heat-risk in London. *Climate Risk Management*, 16, 73-92. <http://dx.doi.org/10.1016/j.crm.2017.01.001>
- KNMI. (n.d.). *KlimaatScenario's*. KNMI. <https://www.knmi.nl/kennis-en-datacentrum/uitleg/knmi-klimaatscenario-s>
- Kwadijk, J., Haasnoot, M., Mulder, J., Hoogvliet, M., Jeuken, A., van der Krogt, R., van Oostrom, N., Schelfhout, H., van Velzen, E., van

- Waveren, H., de Wit, M. (2010). Using adaptation tipping points to prepare for climate change and sea level rise: a case study in the Netherlands. *John Wiley & Sons, Vol 1*, p.729. DOI: 10.1002/wcc.64
- Klimaat-effectatlas (n.d.). Kaartviewer - Klimaat-effectatlas. <https://www.klimaat-effectatlas.nl/nl/>
- Lieftink, L. (2021, november). Pathways for climate-adaptive Haven-Stad: Spatial Adaptive Policy Pathways approach for climate adaptive planning in Haven-Stad, Amsterdam.
- Maine Government. (n.d.). Runoff Peak Discharge Calculations. Maine.gov. Retrieved April 3, 2023, from <https://www.maine.gov/dep/land/stormwater/stormwaterbmps/vol3/appendixa.pdf>
- Manocha, N., Babovic, V. (2017). Development and valuation of adaptation pathways for storm water management infrastructure. *Environmental Science and Policy*, 77, 86-97.
- Ministerie van Algemene Zaken. (2023, February 14). *Ministerie van Binnenlandse Zaken en Koninkrijksrelaties - Rijksoverheid.nl* <https://www.rijksoverheid.nl/ministeries/ministerie-van-binnenlandse-zaken-en-koninkrijksrelaties/onderwerpen>
- Ministerie van Infrastructuur en Milieu. (2016). Nationale Klimaatadaptatie Strategie [https://klimaatadaptatienederland.nl/publish/pages/120542/nas\\_rapport\\_5\\_2\\_1.pdf](https://klimaatadaptatienederland.nl/publish/pages/120542/nas_rapport_5_2_1.pdf)
- Ministerie van Infrastructuur en Waterstaat. (2017). Deltaprogramma 2018 <https://www.deltaprogramma.nl/binaries/deltacommissaris/documenten/publicaties/2017/09/19/dp2018-nl-printversie/DP2018+NL+printversie.pdf>
- Ministerie van Infrastructuur en Waterstaat. (2018). Uitvoeringsprogramma NAS [https://klimaatadaptatienederland.nl/publish/pages/120542/nas\\_rapport\\_5\\_2\\_1.pdf](https://klimaatadaptatienederland.nl/publish/pages/120542/nas_rapport_5_2_1.pdf)
- Ministerie van Infrastructuur en Waterstaat. (2022). Wat is het nationaal Deltaprogramma? Deltaprogramma | Deltaprogramma. <https://www.deltaprogramma.nl/deltaprogramma/wat-is-het-deltaprogramma>
- Mostert, E. (2019). *Nederlands waterrecht voor niet-juristen*. Delft: TU Delft Open. <https://doi.org/10.5074/t.2019.005>
- Norris, L.A., Simpson, C.E., & Garrison, T. (2016). Relationships between surface and groundwater velocities determined from dye trace experiments in McConnel Springs and Preston's Cave Spring, Lexington, Fayette County, Kentucky. *American Institute of Professional Geologists publication*. [https://encompass.eku.edu/cgi/viewcontent.cgi?article=1074&context=fs\\_research](https://encompass.eku.edu/cgi/viewcontent.cgi?article=1074&context=fs_research)
- Offermans, A., Haasnoot, M., & Valkering, P. (2011). A method to explore social response for sustainable water management strategies under changing conditions. *Sustainable Development* (19), 312-324.
- Pickett, S., Cadenasso, M., & Grove, J. (2004). Resilient cities: meaning, models and metaphor for integrating the ecological, socioeconomic, and planning realms. *Landscape and Urban Planning* (69), 369-384.
- Raso, L., Kwakkel, J., Timmermans, J. (2019). Assessing the capacity of adaptive policy pathways to adapt on time by mapping trigger values to their outcomes. *Sustainability*, 11, 1716
- Roggema, R. (2016). Research by design: Proposition for a methodological approach. *Urban science*, 1(1), 2.
- Rijkswaterstaat. (n.d.). *Organisatie waterbeheer*. Kenniscentrum InfoMil. <https://www.infomil.nl/onderwerpen/lucht-water/handboek-water/wetgeving/waterwet/organisatie/>
- Sadr, S., Casal-Campos, A., Farmani, G., Ward, S., Butler, D. (2020). Strategic planning of an integrated urban wastewater system using adaptation pathways. *Water Research*, 182, 116013
- Solcerova, A., Klok, L., & Kluck, J. (2021). Assessment of change in UHI. In T. Haer, & A. Solcerova (Eds.), *Final Report - Impact Assessment at District and City Level* (Output 6.4.1 ed., pp. 25-36). <https://openresearch.amsterdam.nl/page/83679/output-6.4.1-impactassessment-at-district-and-city-level>
- Spaan, K. et al (2018). Regenwater bestendige Gebiedsontwikkeling - Thematische studie voor Ruimte voor de Stad Katern 2. Gemeente Amsterdam en Waternet. [https://www.rainproof.nl/sites/default/files/default\\_katern\\_2\\_regenwaterbestendige\\_gebiedsontwikkeling-klein.pdf](https://www.rainproof.nl/sites/default/files/default_katern_2_regenwaterbestendige_gebiedsontwikkeling-klein.pdf)
- STOWA. (2019). *Neerslagstatistiek en -reeksen voor het waterbeheer 2019*. Amersfoort: Stichting Toegepast Onderzoek Waterbeheer. ISBN 978.90.5773.860.9
- Voskamp, I., & van de Ven, F. (2015). Planning support system for climate adaptation: Composing effective sets of blue green measures to reduce urban vulnerability to extreme weather events. *Building and Environment* (83), 159-167.

Waternet (2021). *Conceptversie Omgevingsplan Riolering*. [www.amsterdam.nl/wonen-leefomgeving/inspraak-conceptversie](http://www.amsterdam.nl/wonen-leefomgeving/inspraak-conceptversie)  
Waterschap Amstel Gooi en Vecht. (n.d.). *Het waterschap en Waternet*. Waterschap Amstel Gooi En Vecht. <https://www.agv.nl/over-ons/het-waterschap-en-waternet/>

Zandvoort, M., Kooijmans, N., Kirshen, P., van den Brink, A. (2019). Designing with Pathways: A Spatial Design Approach for Adaptive and Sustainable Landscapes. *Sustainability*, 11, 565. [doi.org/10.3390/su11030565](https://doi.org/10.3390/su11030565)

Appendix A

# **Planning process**

# 1 Plan- en Besluitvormingsproces Infrastructuur (PBI)



Appendix B

# **Development of pathways**

# 1 Solution space: generated sequences of actions

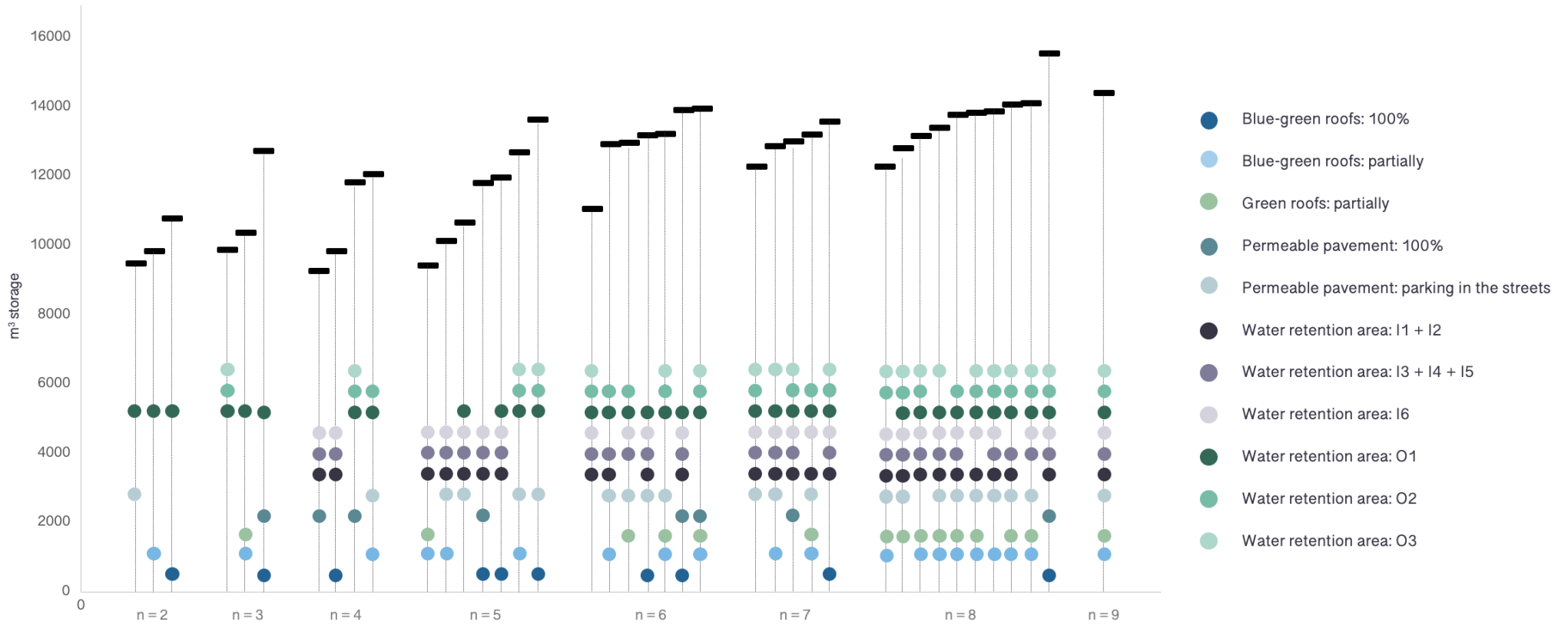

**Figure B.1:** The considered solution space for the development of the pathways, following the DAPP approach. These combinations were randomly generated. The graph shows the potential realized storage per solution and shows which measure is included.

## 2 Alternatives to the realisation of measures in the study area

The following applications of measures were included in generating the possible sequences:

Blue-green roofs partially: creating blue-green roofs on a large part of the flat roof surface, as depicted in Figure 5.1a.

Blue-green roofs 100%: creating blue-green roofs on all flat roof surface.

Green roofs partially: creating green roofs on a small part of the flat roof surface, as depicted in Figure 5.1a.

Permeable pavement on parking spots: creating permeable pavement on the parking spots between the residential buildings, as depicted in Figure 5.1c.

Permeable pavement all: creating permeable pavement on the parking spots and sidewalks between the residential buildings and on the parking space in the shopping area, as depicted in Figure 5.1c.

Water retention areas I1 + I2: creating water retention areas with infiltration facilities at the designated locations I1 and I2, as depicted in Figure 5.1b.

Water retention areas I3 + I4 + I5: idem, for designated locations I3, I4 and I5.

Water retention areas I6: creating a water retention area without an infiltration facility at the designated location I6.

Water retention area O1: creating a water retention area with infiltration facility at the designated location O1

Water retention area O2: creating a water retention area with infiltration facility at the designated location O2

Water retention area O3: creating a water retention area with infiltration facility at the designated location O3

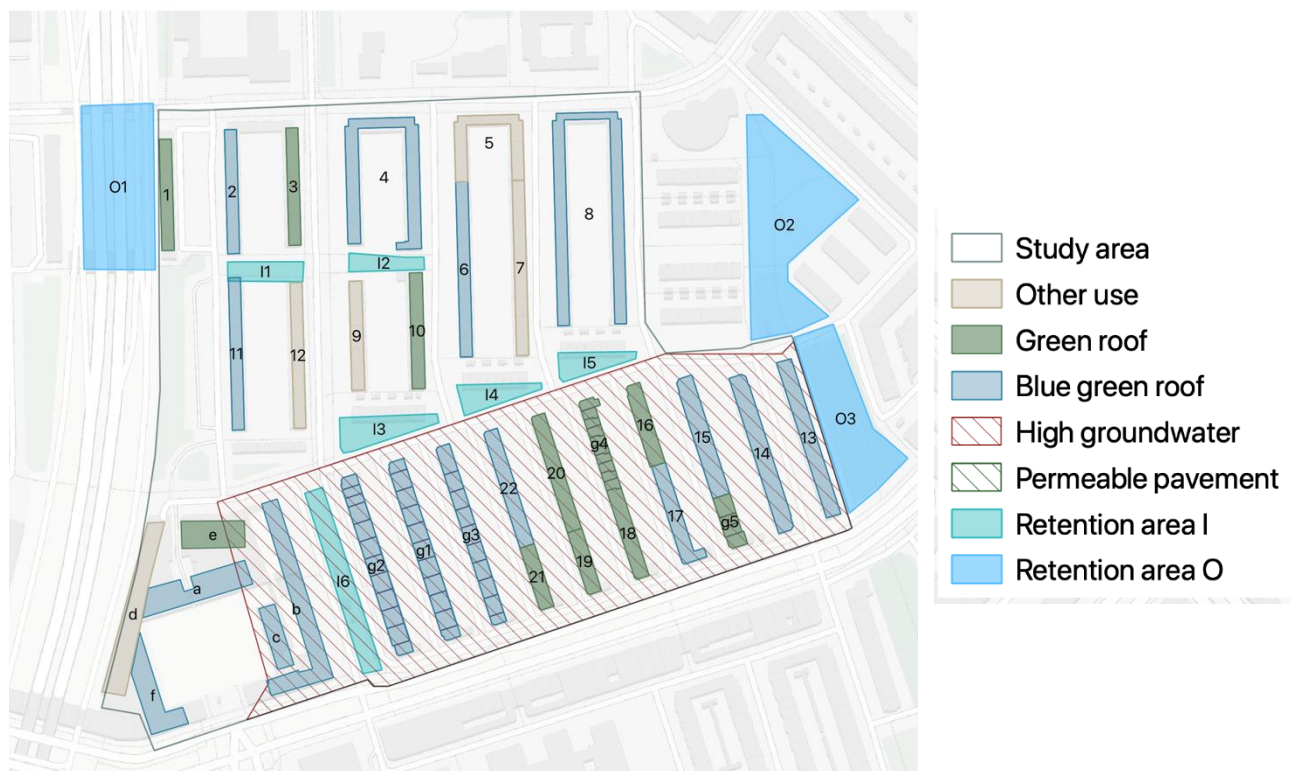

Figure B.2: The locations of the measures with labels to identify each measure location.



### 3 Contribution per measure for each pathway

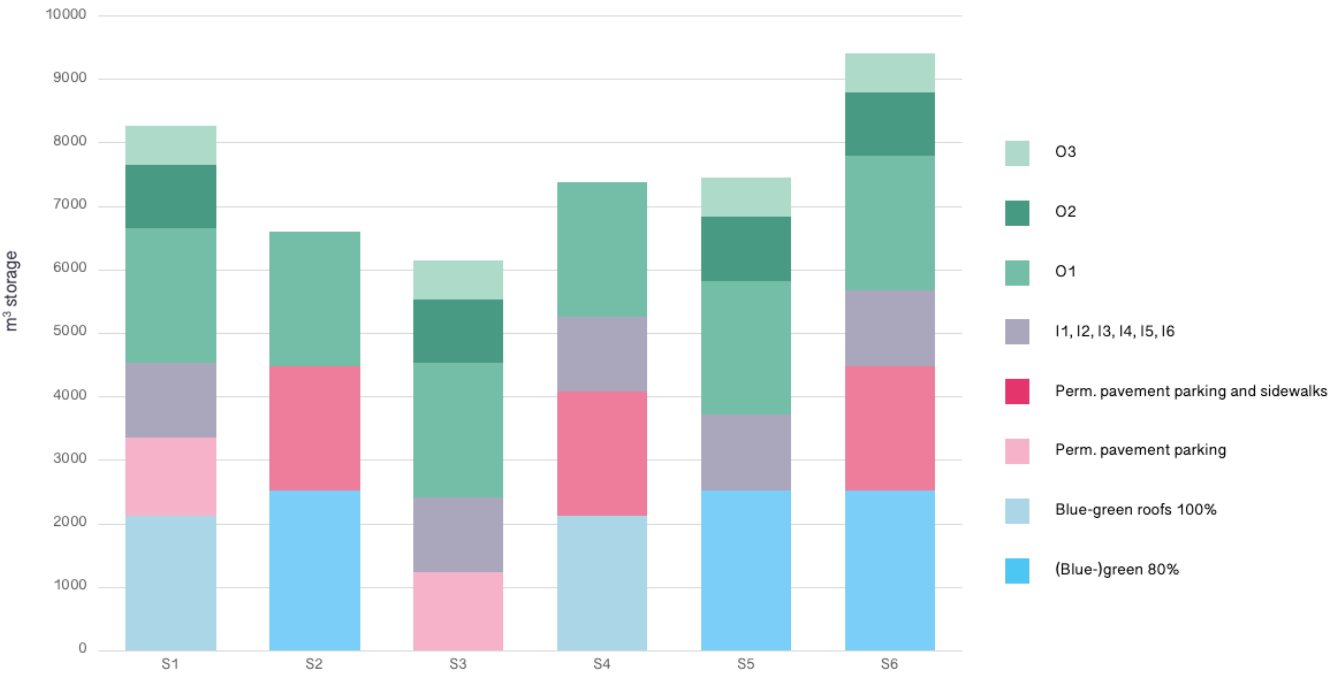

Figure B.3: The contribution to the potential storage capacity in m³ per measure, as indicated with the pathways for alternatives S1-S6.

## 4 Realisation of the measures divided over implementation steps

## 5 Ownership of the rooftop spaces for the implementation steps BG I-VI and G I-II

Step	Buildings	Owned by	
BG I	f, c, a, b	Companies	Owned by housing corporations
BG II	13/13 14/14, 15, 17/17	Housing corporations, residents, project developers/investors	Owned individually but grouped for >200m2
BG III	8	Housing corporations	Individually owned
BG IV	4, 6	Housing corporations, project developers/investors	Project developers
BG V	2, 11	Housing corporations	Voorzieningen (icm wonen-werk)
BG VI	g1, g2, g3, 22	Residents, housing corporations	
Step	Buildings	Owned by	
G I	1, 3, 10, e	Housing corporations, project developers, companies	
G II	16, 18, 19, 20, 21, g4, g5	Housing corporations, residents	
Step	Lots	Owned by	
PP I	Parking space	Municipality	
PP II	Parking space	Municipality	
PP III	Parking space	Municipality	
Step	Lots	Owned by	Type
WR I IV	I1, I2	Municipality	Public space in between residential buildings
WR I V	I3, I4, I5	Municipality	Green space in front of residential buildings
WR I VI	I6	Municipality	Paved square in between shopping centre and residential buildings
Step	Lots	Owned by	Type
WR o IV	O1	Municipality	Public park
WR o V	O2	Municipality	Unused space under the ring A10
WR o VI	O3	Municipality	Public park

Appendix C

## **Surface coverage**

